

- 5) Flat Billing — Certain applications involve service to the load of a fixed characteristic. For such loads, the supplying utility may offer no-meter or flat-connected service. Billing is based upon time and load characteristics. Examples include street lighting, traffic signals, and area lighting.
- 6) Off-Peak Billing — Is reduced billing for service utilized during utility off-peak periods, such as water heating and ice making loads. The utility monitors may control off-peak usage through control equipment or special metering. Off-peak billing is also based upon on-peak and time-of-day, or time-of-use, metering for all billing loads.
- 7) Standby Service Billing — Also known as “breakdown” or “auxiliary service,” this service is applicable to utility customers whose electric requirements are not supplied entirely by the utility. In such cases, billing demand is determined either as a fixed percentage of the connected load or by meter, whichever is higher. This applies to loads that are electrically connected to some other source of supply and for which breakdown or auxiliary service is requested.
- 8) Backup Service Billing — Is provided through more than one utility circuit, solely for a utility customer's convenience. The utility customer customarily bears the cost of establishing the additional circuit and associated supply facilities. Generally, each backup service is separately metered and billed by the utility.
- 9) Demand Billing — Usually represents a significant part of electric service billing and a good understanding of kW demand metering and billing is important. An electric-demand meter measures the average rate of use of electric energy over a given period of time, usually 15 minute, 30 minute, or 60 minute intervals. A demand register records the maximum demand since the last reading. The demand register is reset when recorded for billing purposes.
- 10) Minimum Billing Demand — A utility customer may be subject to minimum demand billing, generally consisting of a fixed amount or a fixed percentage of the maximum demand established over a prior billing period. This type of charge usually applies to customers with high instantaneous demand loads, such as users of welding or x-ray equipment, customers whose operations are seasonal, or those who have contracted for a given service capacity. Equipment requirements and service usage schedules should be carefully reviewed to reduce or avoid minimum billing demand charges.
- 11) Load Factor Billing — The ratio of average kW demand to peak kW demand during a given time period is referred to as the “load factor.” Utilities may offer a billing allowance or credit for high load factor usage, a qualification usually determined by evaluating how many hours during the billing period the metered demand was used. As an example of such a credit, the utility may provide a reduced rate for the number of kWh that are in excess of the maximum (metered) demand multiplied by a given number of hours (after 360 hours for a 720 hour month or a 50% load factor).
- 12) Interruptible or Curtailable Service — Another form of peak-load shaving used by the utilities is interruptible or curtailable service. Primarily available for large facilities with well-defined loads that can be readily disconnected, the utility offers the customer a billing credit for the capability of requesting a demand reduction to a specified contract level during a curtailment period. The monthly credit for each billing month is determined by applying a demand charge credit to the excess of the maximum measured demand used for billing purposes over the contract demand. Should the customer fail to reduce the measured demand during any curtailment period, at least to the contract demand, severe financial penalties may be incurred. An alternative to disconnecting loads is to supply power from in-plant generation.

## 4.5 Transformer Connections

Commercial building utilization of low-voltage, three-phase systems of recent vintage in the United States fall into either of two nominal voltage levels: 208Y/120 V or 480Y/277 V. Either of these systems can supply three-phase or single-phase loads; both frequently exist in the typical commercial building. The transformer connection used to derive these voltages is almost exclusively delta-wye or a specially constructed (such as five-legged core) wye-wye transformer commonly used in pad-mounted transformers. The delta primary cancels out virtually all third harmonic components and multiples thereof that may be introduced in electrical transformation equipment or in lighting ballasts. The secondary wye connection provides a tap for the neutral and convenient grounding point as described in 4.7.1.

When power loads are fed from a separate transformer, the delta-delta connection is excellent from the harmonic and unbalanced load standpoints; but a convenient balanced grounding point is not provided (and, in some instances, may not be desired). There is little need to consider this connection under normal circumstances in new commercial building electric systems.

When systems are to be expanded, existing conditions may dictate the use of other connections than delta-wye or delta-delta. It is important to understand that certain transformer connections are less desirable than others for given applications; and that some connections, such as three single-phase transformers supplying a three-phase, four-wire unbalanced load from a three-wire supply, can actually be destructive (in terms of a floating neutral).

Occasionally, service requirements of the utility may dictate the use of a system with a four-wire wye primary. The following paragraphs cover a few of the limitations of the connections in the special circumstances when the preferred connections listed above cannot be used.

When it is desired to use a wye primary and a wye secondary, consideration should be given to using a shell-type core construction that will carry zero-sequence flux.

The primary or secondary windings of a three-phase transformer can be connected using either delta or wye. It is recommended that at least one of the windings be connected to provide a path for third harmonic currents to circulate.

The wye four-wire primary with the wye four-wire secondary and the wye four-wire primary with the delta three-wire secondary are not to be recommended for use without proper engineering consideration. In three-legged core construction, if one leg of the primary line is lost, the presence of the neutral will provide three-phase flux conditions in the core. The phase that has lost its primary will then become a very high reactance winding, resulting in fringing flux conditions. The flux will leave the core and enter the surrounding magnetic materials, such as the clamping angles, tie rods, enclosure, etc. This produces an effective induction heater and results in a high secondary voltage across the load of the faulty phase. In a matter of seconds, this induction effect can destroy the transformer. It is also possible that, should the fault occur by the grounding of one of the primary lines, the primary winding at fault could then act as a secondary and feed back to the ground, thereby causing high current to flow in this part of the circuit. These conditions are inherent with this type of connection. Whether the transformer is of the dry or liquid type makes no difference.

#### 4.6 Principal Transformer Secondary Connections

Systems of more than 600 V are normally three-phase wye or delta ungrounded, or wye solid or resistance grounded. Systems of 120- 600 V may be either single-phase or three-phase. Three-phase, three-wire systems are usually solidly grounded or ungrounded, but may also be impedance grounded. They are not intended to supply loads connected phase-to-ground. Three-phase, four-wire solidly grounded wye systems are used in most modern commercial buildings. Single-phase services and loads may be supplied from single-phase systems, or from three-wire systems and either phase-to-phase loads (e.g., 208 V) or phase-to-neutral loads (e.g., 120 V) from three-phase, four-wire systems (see Fig 19).

Transformers may be operated in parallel and switched as a unit, provided that the overcurrent protection for each transformer meets the requirements of the NEC, Section 450 [6]. To obtain a balanced division of load current, the transformers should have the same characteristics (rated percent  $IR$  and rated percent  $IX$ ) and be operated on the same voltage-ratio tap. Both  $IR$  and  $IX$  should be equal in order for two transformers to divide the load equally at all power factors of loads.

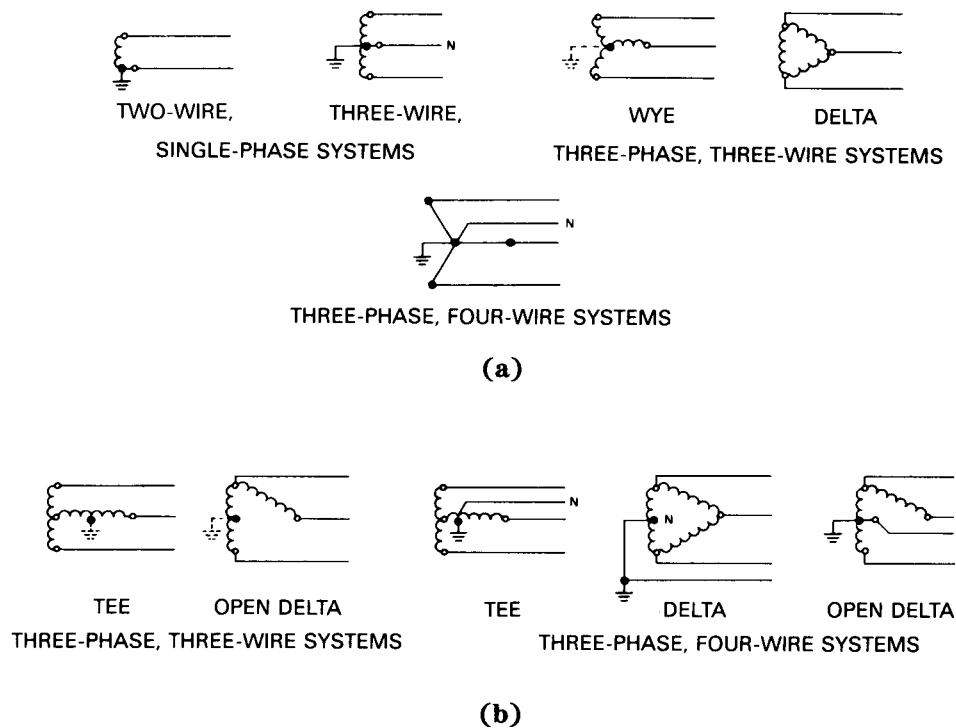

**Figure 19—Transformer Secondary Connections**  
**(a) Most Commonly Used**  
**(b) Least Commonly Used**

## 4.7 System Grounding

IEEE Std 142-1982, IEEE Recommended Practice for Grounding of Industrial and Commercial Power Systems (ANSI) [13] recommends grounding practices for most systems involving grounding of one conductor of the supply, and the NEC [6] requires grounding of certain systems, as described below. The conductor connected to ground is called the “grounded conductor” and should be distinguished from the grounding conductor (equipment grounding conductor), which is the conductor used to connect noncurrent-carrying conductive parts of electrical equipment to ground. This prevents these parts from acquiring a potential above ground as a result of an insulation failure and causing injury to a person who might come in contact with them. System grounding has the following advantages:

- 1) It limits the voltages due to lightning, line surges, or unintentional contact with higher voltage lines and stabilizes the voltage to ground during normal operation.
- 2) It limits or prevents the generation of transient overvoltages by changes in the electrostatic potential to ground caused by an intermittent ground on one of the conductors of an ungrounded system.
- 3) In combination with equipment grounding, it can be designed to provide a safe method of protecting electric distribution systems by causing the overcurrent or ground-fault protective equipment to operate to disconnect the circuit in case of a ground fault.
- 4) It stabilizes the voltage to ground of line conductors should one of the line conductors develop a fault to ground.

### 4.7.1 Grounding of Low-Voltage Systems (600 V and Below)

The NEC [6] requires that the following low-voltage systems be grounded:

- 1) Systems that can be grounded so that the voltage to ground of any ungrounded conductor does not exceed 150 V. This makes grounding mandatory for the 208Y/120 V three-phase, four-wire system and the 120/240 V single-phase, three-wire system.
- 2) Any system in which load is connected between any ungrounded conductor and the grounded conductor. This extends mandatory grounding to the 480Y/277 V three-phase, four-wire system. The 240/120 V, i.e., 240 $\Delta$ /120 V three-phase, four-wire, open-delta, center-tap ground system, is sometimes supplied for small commercial buildings, where the single-phase load is high and the three-phase load is minimal.
- 3) The NEC [6] has special requirements for grounding dc systems and ac systems under 50 V.

The grounded conductor is called the “neutral” on three-phase wye connected systems and single-phase, three-wire systems since it is common to all ungrounded conductors. The NEC [6] requires the grounded conductor to be identified to prevent confusion with the ungrounded conductors.

A few utilities provide 240 V and 480 V three-phase, three-wire systems with one phase grounded (corner grounded). This type of grounding is not recommended for commercial buildings and should be accepted only if a suitable alternative system will not be provided.

The NEC [6] requires that separately derived systems be grounded in accordance with its rules. An example of a separately derived system is one in which a transformer is used to derive another voltage. The best examples of this are the transformation from a 480 V system to 208Y/120 V or 240/120 V to supply a 120 V load.

An exception to the NEC's grounding requirements is permitted for health care facilities (see the NEC, Article 517 [6]) where the use of a grounded system might subject a patient to electrocution or a spark might ignite an explosive atmosphere in case of an insulation failure (see Chapter 16).

The 240 V, 480 V, and 600 V three-phase, three-wire systems are not required to be grounded; but these systems are not recommended for commercial buildings. When they are used, consideration should be given to providing a derived ground by using a zigzag transformer or delta-wye grounding transformer to obtain the advantages of grounding and limit the damage as described above.

### 4.7.2 Grounding of Medium-Voltage Systems (Over 600 V)

Medium-voltage systems are encountered in commercial buildings when the building becomes too large to be supplied from a single transformer station and the utility primary distribution voltage should be taken through or around the building or buildings to supply the various transformers. Many utility distribution systems are solidly grounded to permit single-phase transformers to be connected phase-to-neutral to supply residences and other small loads, although ungrounded or impedance-grounded systems may occasionally be encountered. The designer should accept whatever grounding system the supplying utility provides. About the only time that the designer has a choice in the grounding of medium-voltage systems is when the supplying utility provides a voltage over 15 000 V and the designer elects to step this voltage down to a lower voltage to distribute through the building, or where large motors (several hundred horsepower) are required, such as in large airconditioning installations, and it is more economical to use an intermediate voltage, such as 4160 V.

Under these conditions, one method to use is a wye-connected system and then ground the neutral through a resistance that is low enough to stabilize the system voltages but high enough to limit the ground-fault current to a value that will not cause extensive equipment damage before the protective devices can operate. (See IEEE Std 142-1982 (ANSI) [13] for more details.) Since the ground-fault current is limited, ground-fault protection should be installed in addition to phase overcurrent protection to disconnect the circuit in case of a ground fault.

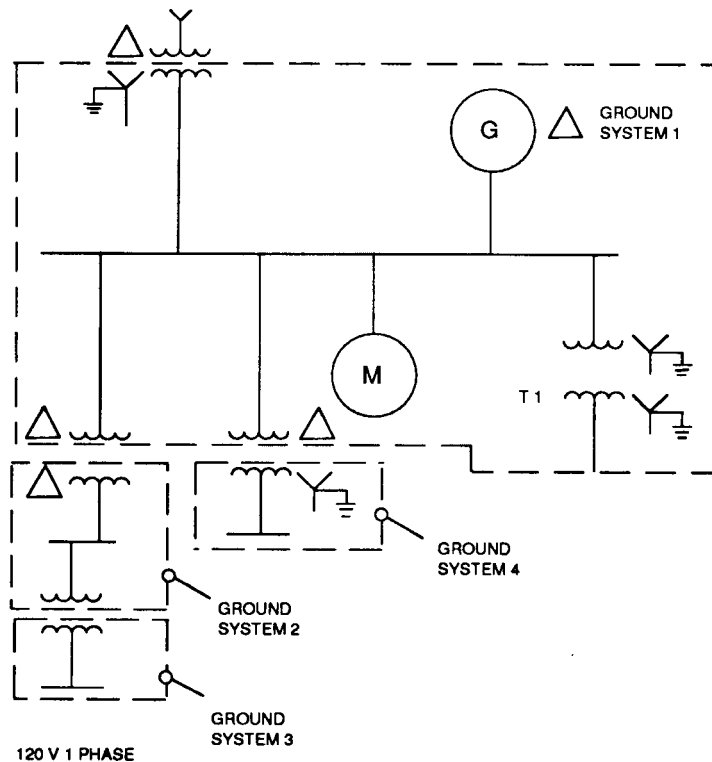

Figure 1—Grounding Systems

## 1.4 Methods of System Neutral Grounding

### 1.4.1 Introduction

Most grounded systems employ some method of grounding the system neutral at one or more points. These methods can be divided into two general categories: Solid grounding and impedance grounding. Impedance grounding may be further divided into several subcategories: Reactance grounding, resistance grounding and ground-fault-neutralizer grounding. Fig 2 shows examples of these methods of grounding. Each method, as named, refers to the nature of the external circuit from system neutral to ground rather than to the degree of grounding. In each case the impedance of the generator or transformer whose neutral is grounded is in series with the external circuit. Thus a solidly grounded generator or transformer may or may not furnish effective grounding to the system, depending on the system source impedance.

Many of the concepts involved in defining system-grounding types and levels are best explained in terms of symmetrical components or equivalent circuits. The reader who is not familiar with these analytical methods is referred to Chapter 2 of Beeman [10] and to Chapter 3 of the *IEEE Brown Book* [5] for guidance.

Molded-case circuit-breaker interrupting capabilities can be affected by the method of grounding. If other than effective grounding is used, circuit breakers should be reevaluated for the application.

### 1.4.2 Ungrounded Systems (No Intentional Grounding)

Electrical power systems which are operated with no intentional ground connection to the system conductors are generally described as ungrounded. In reality, these systems are grounded through the system capacitance to ground.

In most systems, this is an extremely high impedance, and the resulting system relationships to ground are weak and easily distorted.

Two principal advantages are attributed to ungrounded systems. The first is operational: The first ground fault on a system causes only a small ground current to flow, so the system may be operated with a ground fault present, improving system continuity. The second is economic: No expenditures are required for grounding equipment or grounded system conductors.

Numerous advantages are attributed to grounded systems, including greater safety, freedom from excessive system overvoltages that can occur on ungrounded systems during arcing, resonant or near-resonant ground faults, and easier detection and location of ground faults when they do occur.

Resonant effects can occur when the ground fault path includes an inductive reactance approximately equal to the system capacitive reactance to ground. Beeman [10], pp. 281–285, discusses this phenomenon in depth. For an extensive discussion of the advantages of grounded systems, see pp 345–348 of Beeman [10]. Also, Article 250–5 of [1] requires certain systems to be grounded. Grounded systems are now the predominant choice.

When an ungrounded system is chosen, a ground detection scheme may be applied to the system. This scheme frequently takes the form of three voltage transformers with their primary windings connected in wye and with the primary neutral grounded. The secondary windings of the voltage transformers are usually connected in broken delta, with a voltage relay connected in the open corner and used to operate an indication or alarm circuit. Loading resistors may be required either in the primary neutral circuit or in the secondary circuit to avoid ferroresonance.

### 1.4.3 Resistance Grounding

In resistance grounding, the neutral is connected to ground through one or more resistors. In this method, with the resistor values normally used, and except for transient overvoltages, the line-to-ground voltages that exist during a line-to-ground fault are nearly the same as those for an ungrounded system.

A system properly grounded by resistance is not subject to destructive transient overvoltages. For resistance-grounded systems at 15 kV and below, such overvoltages will not ordinarily be of a serious nature if the resistance value lies within the following boundary limits:  $R_0 \leq X_{C0}$ ,  $R_0 \geq 2X_0$ . The corresponding ground-fault current is far less than is normally used for low-resistance grounding, but is the design criterion for high-resistance grounding.

The reasons for limiting the current by resistance grounding may be one or more of the following.

- 1) To reduce burning and melting effects in faulted electric equipment, such as switchgear, transformers, cables, and rotating machines.
- 2) To reduce mechanical stresses in circuits and apparatus carrying fault currents.
- 3) To reduce electric-shock hazards to personnel caused by stray ground-fault currents in the ground return path.
- 4) To reduce the arc blast or flash hazard to personnel who may have accidentally caused or who happen to be in close proximity to the ground fault.
- 5) To reduce the momentary line-voltage dip occasioned by the occurrence and clearing of a ground fault.
- 6) To secure control of transient overvoltages while at the same time avoiding the shutdown of a faulty circuit on the occurrence of the first ground fault (high-resistance grounding).

Resistance grounding may be either of two classes, high resistance or low resistance, distinguished by the magnitude of ground-fault current permitted to flow. Although there are no recognized standards for the levels of ground-fault current that define these two classes, in practice there is a clear difference. High-resistance grounding typically uses ground-fault current levels of 10 A or less, although some specialized systems at voltages in the 15 kV class may have higher ground-fault current levels. Low-resistance grounding typically uses ground-fault current levels of at least 100 A, with currents in the 200–1000 A range being more usual.

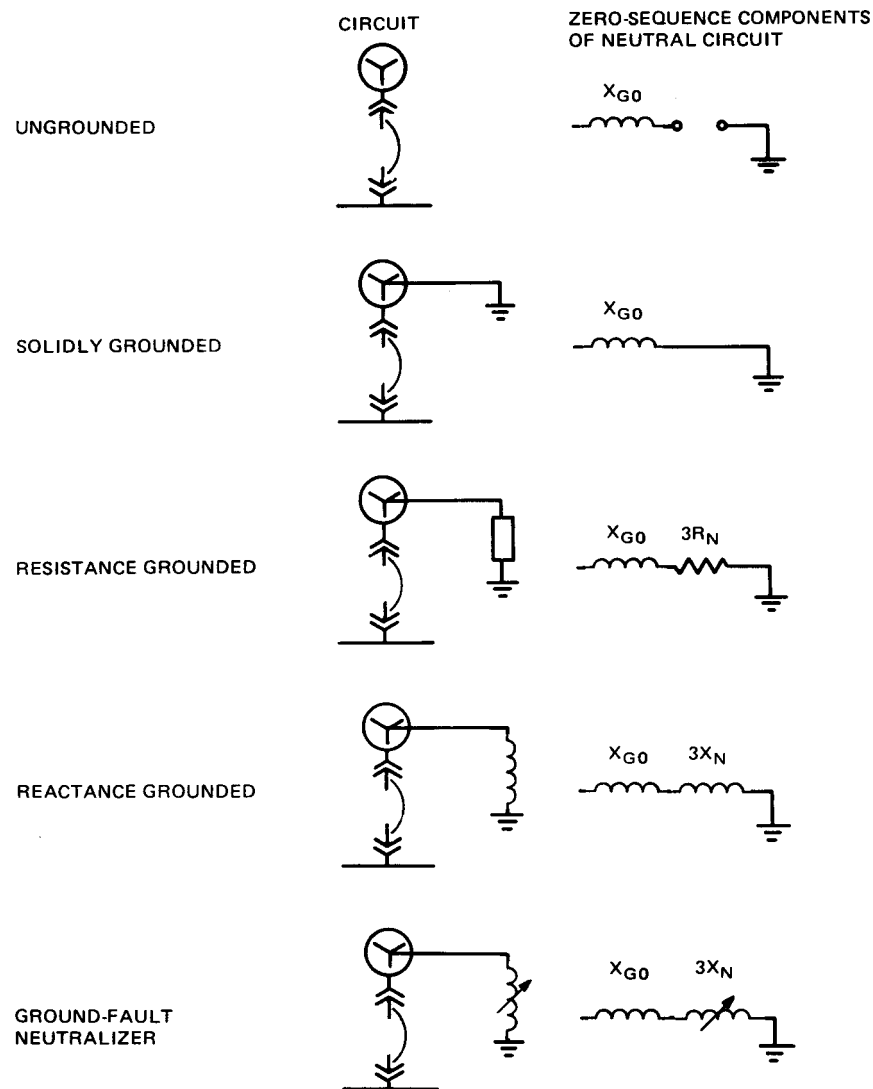

$X_{G0}$  = Zero-sequence reactance of generator or transformer  
 $X_N$  = Reactance of grounding reactor  
 $R_N$  = Resistance of grounding resistor

**Figure 2—System Neutral Circuit and Equivalent Diagrams for Ungrounded and Various Types of Grounded-Neutral Systems**

Both types are designed to limit transient overvoltages to a safe level (within 250% of normal). However, the high-resistance method usually does not require immediate clearing of a ground fault since the fault current is limited to a very low level. This low level must be at least equal to the system total capacitance-to-ground charging current. The protective scheme associated with high-resistance grounding is usually detection and alarm rather than immediate tripout. In general the use of high-resistance grounding on systems where the line-to-ground fault current exceeds 10 A should be avoided because of the damage potential of an arcing current larger than 10 A in a confined space.

The low-resistance method has the advantage of immediate and selective clearing of the grounded circuit, but requires that the minimum ground-fault current be large enough to positively actuate the applied ground-fault relay. High-resistance grounding is a method that can be applied to existing medium-voltage ungrounded systems to obtain the transient overvoltage protection without the modification expense of adding ground relays to each circuit.

Systems grounded through resistors require surge arresters suitable for use on ungrounded-neutral circuits. Metal oxide surge arrester ratings must be chosen so that neither the maximum continuous operating voltage capability nor the one-second temporary overvoltage capability is exceeded under system ground fault conditions.

#### 1.4.4 Reactance Grounding

The term *reactance grounding* describes the case in which a reactor is connected between the system neutral and ground. Since the ground-fault that may flow in a reactance-grounded system is a function of the neutral reactance, the magnitude of the ground-fault current is often used as a criterion for describing the degree of grounding. In a reactance-grounded system, the available ground-fault current should be at least 25% and preferably 60% of the three-phase fault current to prevent serious transient overvoltages ( $X_0 \leq 10X_1$ ). This is considerably higher than the level of fault current desirable in a resistance-grounded system, and therefore reactance grounding is usually not considered an alternative to resistance grounding.

In most generators, solid grounding, that is, grounding without external impedance, may permit the maximum ground-fault current from the generator to exceed the maximum three-phase fault current that the generator can deliver and for which its windings are braced. Consequently, neutral-grounded generators should be grounded through a low-value reactor that will limit the ground-fault current to a value no greater than the generator three-phase fault current. In the case of three-phase four-wire systems, the limitation of ground-fault current to 100% of the three-phase fault current is usually practical without interfering with normal four-wire operation. In practice, reactance grounding is generally used only in this case and to ground substation transformers with similar characteristics.

#### 1.4.5 Ground-Fault Neutralizer (Resonant Grounding)

A ground-fault neutralizer is a reactor connected between the neutral of a system and ground and having a specially selected, relatively high value of reactance. The reactance is tuned to the system charging current so that the resulting ground fault current is resistive and of a low magnitude. This current is in phase with the line-to-neutral voltage, so that current zero and voltage zero occur simultaneously. If the ground fault is in air, such as an insulator flashover, it may be self-extinguishing. This method of grounding is used primarily on systems above 15 kV, consisting largely of overhead transmission or distribution lines. Since systems of such construction are rarely used in industrial or commercial power systems, the ground-fault neutralizer finds little application in these systems. For further information on the use of ground-fault neutralizers, see Reference [9].

#### 1.4.6 Solid Grounding

Solid grounding refers to the connection of the neutral of a generator, power transformer, or grounding transformer directly to the station ground or to the earth.

Because of the reactance of the grounded generator or transformer in series with the neutral circuit, a solid ground connection does not provide a zero-impedance neutral circuit. If the reactance of the system zero-sequence circuit is too great with respect to the system positive-sequence reactance, the objectives sought in grounding, principally freedom from transient overvoltages, may not be achieved. This is rarely a problem in typical industrial and commercial power systems. The zero-sequence impedance of most generators used in these systems is much lower than the positive-sequence impedance of these generators. The zero-sequence impedance of a delta-wye transformer will not exceed the transformer's positive-sequence impedance. There are, however, conditions under which relatively high zero-sequence impedance may occur.



One of these conditions is a power system fed by several generators and/or transformers in parallel. If the neutral of only one source is grounded, it is possible for the zero-sequence impedance of the grounded source to exceed the effective positive-sequence impedance of the several sources in parallel.

Another such condition may occur where power is distributed to remote facilities by an overhead line without a metallic ground return path. In this case, the return path for ground-fault current is through the earth, and, even though both the neutral of the source and the nonconducting parts at the load may be grounded with well-made electrodes, the ground return path includes the impedance of both of these ground electrodes. This impedance may be significant. Another significant source of zero sequence impedance is the large line-to-ground spacing of the overhead line.

To ensure the benefits of solid grounding, it is necessary to determine the degree of grounding provided in the system. A good guide in answering this question is the magnitude of ground-fault current as compared to the system three-phase fault current. The higher the ground-fault current in relation to the three-phase fault current the greater the degree of grounding in the system. Effectively grounded systems will have a line-to-ground short circuit current of at least 60% of the three-phase short-circuit value. In terms of resistance and reactance, effective grounding of a system is accomplished only when  $R_0 \leq X_1$  and  $X_0 \leq 3X_1$  and such relationships exist at any point in the system. The  $X_1$  component used in the above relation is the Thevenin equivalent positive-sequence reactance of the complete system including the subtransient reactance of all rotating machines.

Application of surge arresters for grounded-neutral service requires that the system be effectively grounded.

#### 1.4.7 Obtaining the System Neutral

The best way to obtain the system neutral for grounding purposes in three-phase systems is to use source transformers or generators with wye-connected windings. The neutral is then readily available. Such transformers are available for practically all voltages except 240 V. On new systems, 208Y/120 V or 480Y/277 V wye-connected transformers may be used to good advantage instead of 240 V. Wye-connected source transformers for 2400, 4160, and 13 800 V systems are available as a standard option, whereas 4800 and 6900 V wye-connected source transformers may be priced at a premium rate. The alternative is to apply grounding transformers.

System neutrals may not be available, particularly in many old systems of 600 V or less and many existing 2400, 4800, and 6900 V systems. When existing delta-connected systems are to be grounded, grounding transformers may be used to obtain the neutral. Grounding transformers may be of either the zigzag, the wye-delta, or the T-connected type. One type of grounding transformer commonly used is a three-phase zigzag transformer with no secondary winding. The internal connection of the transformer is illustrated in Fig 3. The impedance of the transformer to balanced three-phase voltages is high so that when there is no fault on the system, only a small magnetizing current flows in the transformer winding. The transformer impedance to zero-sequence voltages, however, is low so that it allows high ground-fault currents to flow. The transformer divides the ground-fault current into three equal components; these currents are in phase with each other and flow in the three windings of the grounding transformer. The method of winding is seen from Fig 3 to be such that when these three equal currents flow, the current in one section of the winding of each leg of the core is in a direction opposite to that in the other section of the winding on that leg. This tends to force the ground-fault current to have equal division in the three lines and accounts for the low impedance of the transformer-to-ground currents.

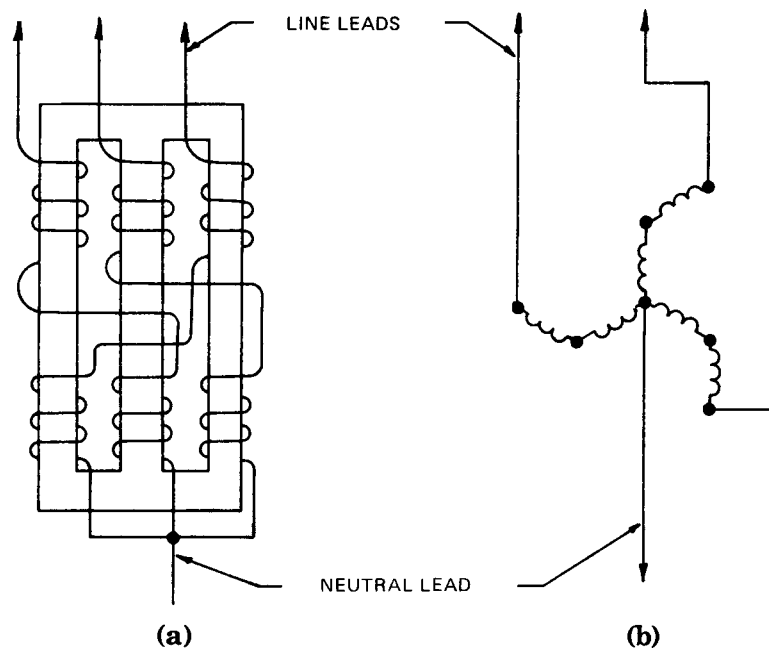

**Figure 3—(a) Core Windings  
(b) Connections of Three-Phase Zigzag Grounding Transformer**

A wye-delta-connected three-phase transformer or transformer bank can also be utilized for system grounding. As in the case of the zigzag grounding transformer, the usual application is to accomplish resistance-type grounding of an existing ungrounded system. The delta connection must be closed to provide a path for the zero-sequence current, and the delta voltage rating is selected for any standard value. A resistor inserted between the primary neutral and ground, as shown in Fig 4, provides a means for limiting ground-fault current to a level satisfying the criteria for resistance-grounded systems. For this arrangement, the voltage rating of the wye winding need not be greater than the normal line-to-neutral system voltage. For high-resistance grounding it is sometimes more practical or economical to apply the limiting resistor in the secondary delta connection. Three single-phase distribution class transformers are used, with the primary wye neutral connected directly to ground. The secondary delta is closed through a resistor that effectively limits the primary ground-fault current to the desired low level. For this alternative application, the voltage rating of each of the transformer windings forming the wye primary should not be less than the system line-to-line voltage.

The rating of a three-phase grounding transformer or bank, in kVA, is equal to the rated line-to-neutral voltage in kilovolts times the rated neutral current [18]. Most grounding transformers are designed to carry their rated current for a limited time only, such as 10 s or 1 min. Consequently, they are much smaller in size than an ordinary three-phase continuously rated transformer with the same rating.

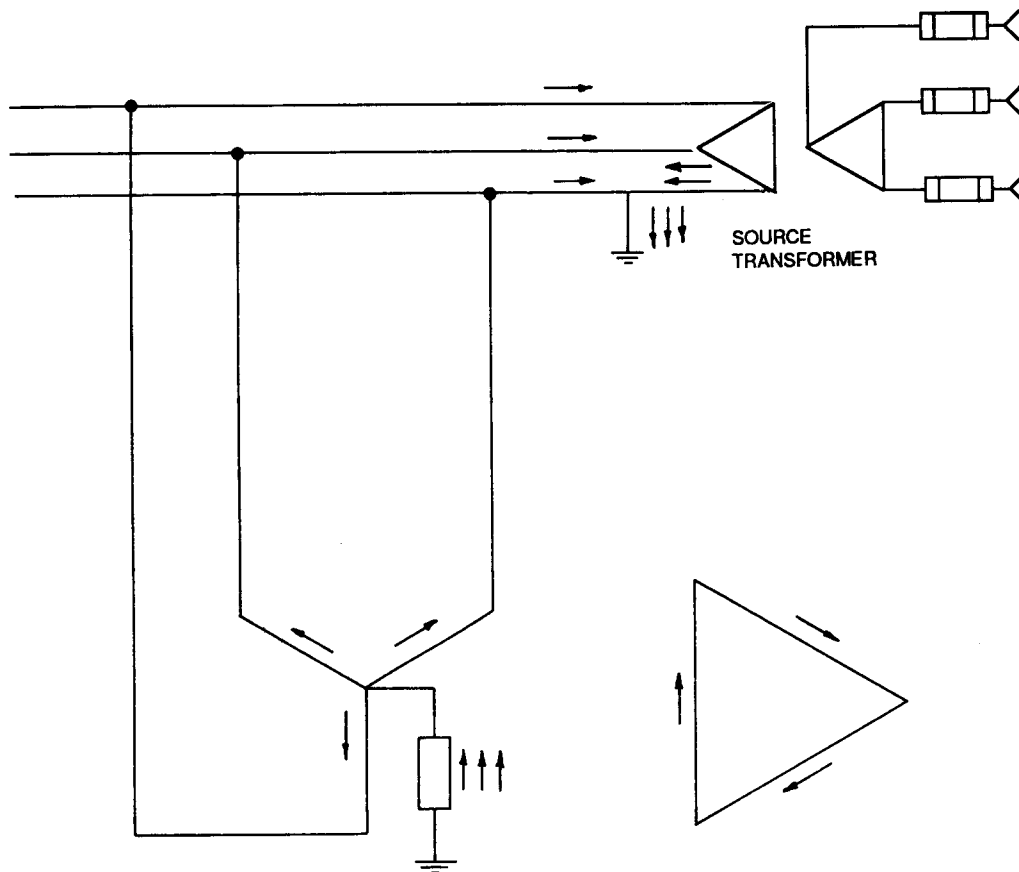

**Figure 4—Vectors Representing Current Flow in Wye-Delta Transformer Used as Grounding Transformer with Line-to Ground Fault**

It is generally desirable to connect a grounding transformer directly to the main bus of a power system, without intervening circuit breakers or fuses, to prevent the transformer from being inadvertently taken out of service by the operation of the intervening devices. (In this case the transformer is considered part of the bus and is protected by the relaying applied for bus protection.) Alternatively, the grounding transformer should be served by a dedicated feeder circuit breaker, as shown in Fig 5(a), or connected between the main transformer and the main switchgear, as illustrated in Fig 5(b). If the grounding transformer is connected as shown in Fig 5(b), there should be one grounding transformer for each delta-connected bank supplying power to the system, or enough grounding transformers to assure at least one grounding transformer on the system at all times. When the grounding transformer is so connected, it is included in the protective system of the main transformer.

### 1.5 Grounding at Points Other than System Neutral

In some cases, low-voltage systems (600 V and below) are grounded at some point other than the system neutral to obtain a grounded electrical system. This is done where existing delta transformer connections do not provide access to the system neutral. Two systems are in general use.

### 1.5.1 Corner-of-the-Delta Systems

Low-voltage systems, which in the past have been nearly all supplied from transformers with delta-connected secondaries, have been ungrounded. Grounding of one-phase corner-of-the-delta grounding has sometimes been used as a means of obtaining a grounded system. The advantages are the following:

- 1) It is the least costly method of converting an ungrounded delta system to a grounded system. This method was adapted by one very large industrial company in 1935 for their older plants. No problems have been reported and it is still in use. The first costs of a new transformer are approximately the same for either a delta or a wye secondary connection.
- 2) Although motor overload protection, theoretically, is needed only in the two phases that are not grounded, the NEC Table 430-37 states that for three-phase systems, three overloads are required, one in each phase. The advantage in the past of having only two overloads is no longer viable.
- 3) With properly connected control circuits, ground faults in the control circuit will neither start the motor nor prevent stopping the motor by means of the stop push button.
- 4) There is a high probability of sustaining arcing for 480 V or higher, phase-to-phase, single-phase circuit extension, without escalation to a three-phase fault.
- 5) The corner-grounded system will effectively control transient and overvoltages; however, a maximum of 1.73 times the normal phase-to-neutral voltage can exist between two conductors and the ground.
- 6) A fault from phase to ground is easily detected and found.

The disadvantages are the following:

- 1) An inability to supply dual-voltage service for lighting and power loads.
- 2) The necessity of positive identification of the grounded phase throughout the system to avoid connecting meters, fuses, instruments, and relays in the grounded phase.
- 3) A higher line-to-ground voltage on two phases than in a neutral-grounded system.
- 4) The possibility of exceeding interrupting capabilities of marginally applied circuit breakers, because for a ground fault, the interrupting duty on the affected circuit-breaker pole exceeds the three-phase fault duty.

Because of its limitations, this type of grounding has not been widely used in industrial systems.

### 1.5.2 One Phase of a Delta System Grounded at Midpoint

In some areas where the utility had a large single-phase 120/240 V load and a small three-phase 240 V load, they have supplied a large single-phase 120/240 transformer and one or two smaller 240 V transformers. In other cases where three single-phase transformers are connected in delta, the midpoint, if available, is grounded. With this method it is possible to gain some of the advantages of neutral grounding by grounding the midpoint of one phase. This method does not provide all the advantages of a system neutral grounding and is not recommended for voltages over 240 V. The advantages are the following:

- 1) The first costs are approximately the same as a solidly grounded system.
- 2) Fast tripping for phase-to-ground faults.
- 3) Mid-phase grounding effectively controls, to safe levels, the over-voltages.

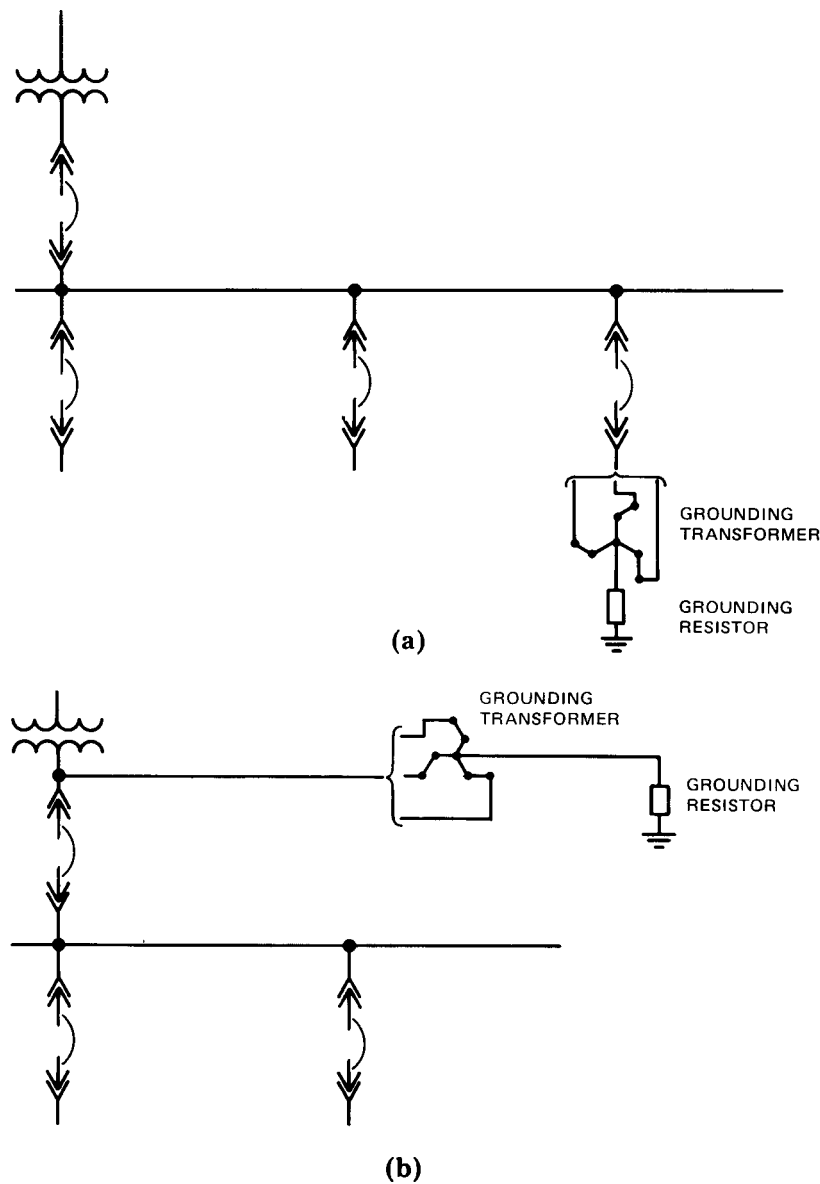

**Figure 5—Methods of Connecting Grounding Transformer to a Delta-Connected or Ungrounded Power System to Form Neutral for System Grounding**

The disadvantages are the following:

- 1) The shock hazard of the high phase leg to ground is 1.73 times the voltage from the other two phases.
- 2) There must be positive identification of the conductor with the highest voltage to ground to avoid connecting 120 V loads to that conductor.
- 3) Serious flash hazard from a phase-to-ground fault can exist because of the high fault levels.
- 4) The cost of maintenance is somewhat above the neutral grounded system due to the sustained higher voltage and insulation stress on one phase.
- 5) Grounding of one phase of a delta system at the midpoint of that phase for three-phase systems with phase-to-phase voltages over 240 V has little application.

## 1.6 Location of System Grounding Points

### 1.6.1 Selection

Each system as described in 1.2 of this chapter is defined by “its isolation from adjacent grounding systems. The isolation is provided by transformer primary and secondary windings.” The new system created by each transformer or generator requires the establishment of a new system ground.

The selection of a system grounding point is influenced by whether the transformer or generator windings are connected “wye” or “delta” “Delta-wye” or “wye-delta” transformers effectively block the flow of zero-sequence current between systems. Although the wye connection is generally more conducive to system grounding because of the availability of a neutral connection, that fact alone should not be the sole criteria for the location of the system ground point.

The system ground point should always be at the power source. An archaic concept of grounding at the load or at other points in the system because of the availability of a convenient grounding point is not recommended because of the problems caused by multiple ground paths and because of the danger that the system could be left ungrounded and therefore unsafe. The National Electrical Code recognizes this danger and prohibits system grounding at any place except the source and/or service equipment.

As previously described in 1.4.6 of this chapter, grounding of other than neutrals may be accomplished with the use of zigzag grounding transformers or grounded wye primary-delta secondary grounding transformer banks connected directly to the phase bus.

### 1.6.2 Single Power Source

When a system has only one source of power (generator or transformer), grounding may be accomplished by connecting the source neutral to earth either directly or through a neutral impedance (Fig 6). Provision of a switch or circuit breaker to open the neutral circuit is not recommended. It is not desirable to operate the system ungrounded by having the ground connection open while the generator or transformer is in service.

In the event that some means of disconnecting the ground connection is required for measurement, testing, or repair, a disconnecting link should be used and only opened when the system is de-energized.

### 1.6.3 Multiple Power Sources

For installation with multiple power sources (i.e., generators or power transformers) interconnected that are or can be operated in parallel, the system ground can be accomplished in one of two ways:

- 1) Each source grounded, with or without impedance (Fig 7).
- 2) Each source neutral connected to a common neutral bus, which is the grounded, with or without impedance (Fig 8).

For Solidly Grounded Systems with multiple sources where all sources must be solidly grounded, it is always acceptable to separately ground each power source as shown in Fig 7(a). Levels of fault current are determined by the number and available fault current of each interconnected source. Where sources are in close proximity, Common Ground Point connection [Fig 8(a)] will allow for selective relaying to identify and isolate only the faulted source.

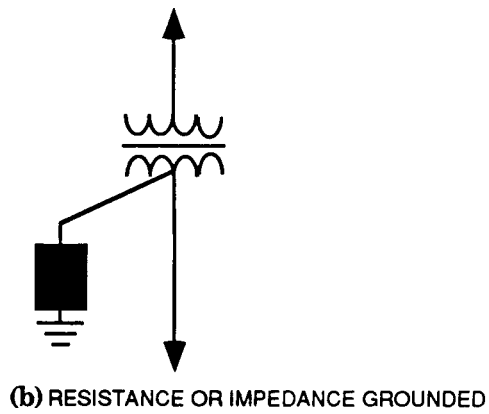
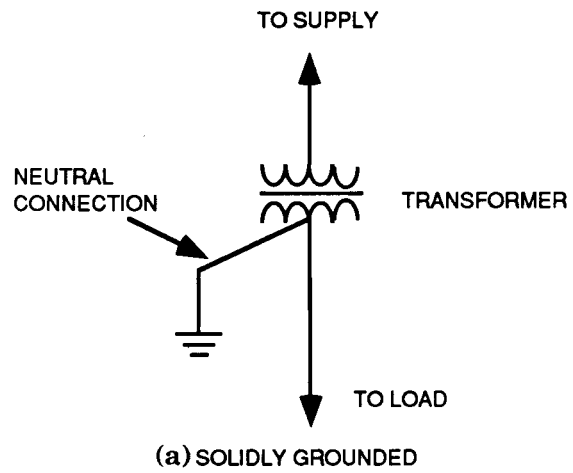
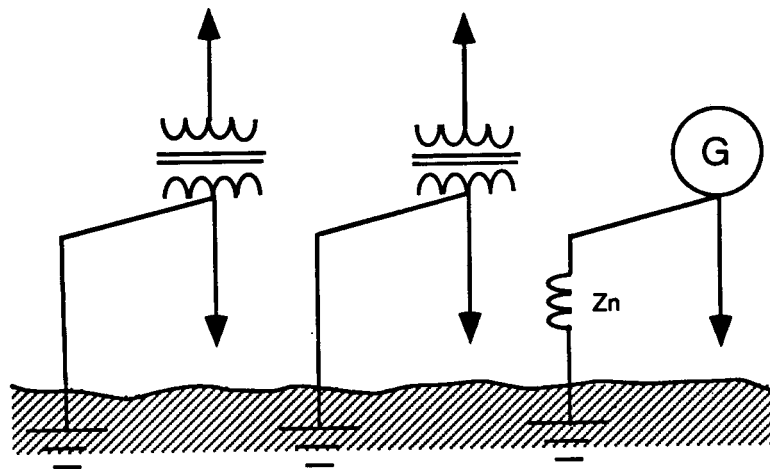

Figure 6—Grounding for Systems with One Source of Power



$$Z_n \approx \frac{X_d''}{3}$$

(SEE 1.8.5)

(a) SOLIDLY GROUNDED

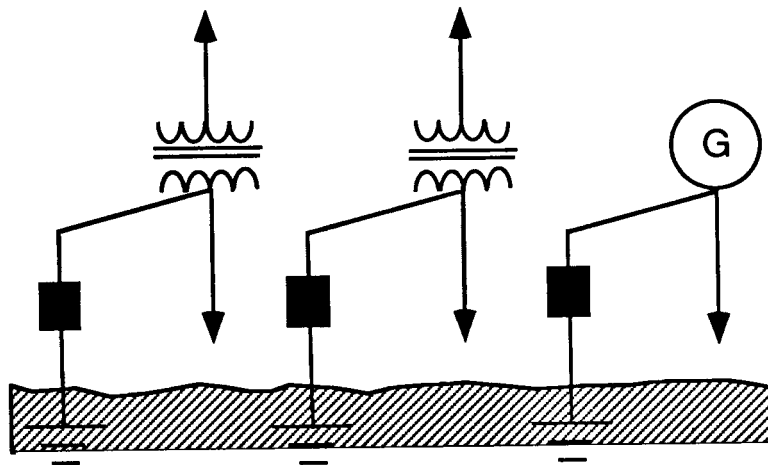

(b) RORZ GROUNDED

Figure 7—Grounding for Systems with Multiple Power Sources  
(Method 1)



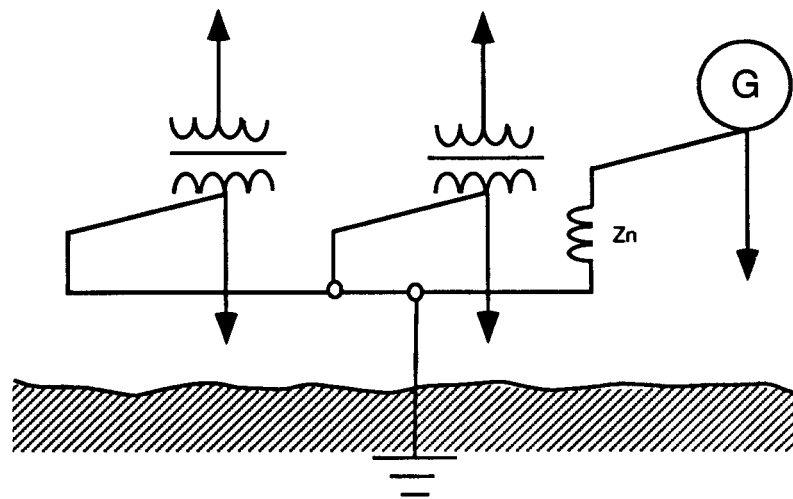

(a) SOLIDLY GROUNDED

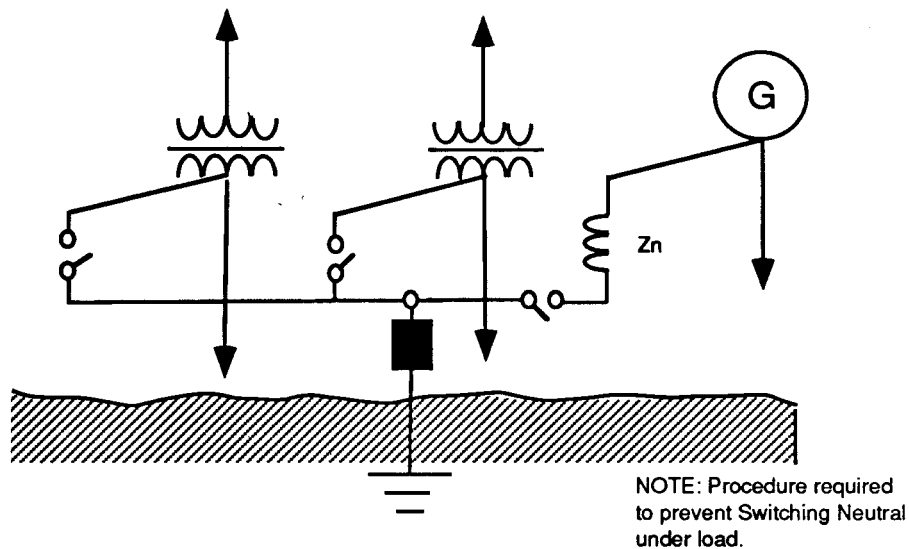

(b) R OR Z GROUNDED WITH NEUTRAL SWITCHING

**Figure 8—Grounding for Systems with Multiple Power Sources  
(Method 2)**

If the power sources are not in close proximity, Common Ground Point is not recommended. The impedance in the neutral bus connection may become large enough to prevent effectively grounding the neutral of the source at the remote location. The interconnect may inadvertently become open, allowing the transformer to operate ungrounded.

For Impedance Grounded Systems it is always acceptable to separately connect each neutral to ground through individual impedances [Fig 7(b)]. Each impedance rating should allow sufficient current to satisfy the criteria for the grounding system being used.

Individual neutral switching devices (automatic or manual) are not recommended, since incorrect operation may allow a power source to operate ungrounded.

System relaying is more complex when such impedance grounding is used, because of multiple grounding points. Capability of detecting a ground fault at any point in the system requires sensing at each ground point in addition to any normal feeder protection. The fault current sensed by the feeder is variable, depending on the number of sources that are grounded at the time of the fault.

When individual impedances are used, circulation of third-harmonic currents between paralleled generators is not a problem since the impedance limits the circulating current to negligible values. When total ground-fault currents with several individual impedances would exceed about 1000–4000 A, a Common Ground Point and single impedance to limit the fault current should be considered [Fig 8(b)]. The advantage of this connection is that the maximum fault current is known and selective relaying can be used to open tie breakers and selectively isolate the faulted bus.

The primary purpose of neutral disconnecting devices in impedance grounded systems is to isolate the generator or transformer neutral from the neutral bus when the source is taken out of service, because the neutral bus is energized during ground faults. A generator or transformer disconnected from the power bus, but with an unbroken connection of its neutral to a neutral bus, would have all of its terminals elevated with respect to ground during a ground fault. Disconnecting devices should be metal-enclosed and interlocked in such a manner as to prevent their operation except when the transformer primary and secondary switches or generator main and field circuit breakers are open.

In the case of multiple transformers, all neutral isolating devices may be normally closed because the presence of delta-connected windings (which are nearly always present on at least one side of each transformer) minimizes the circulation of harmonic current between transformers. Generators that are designed to suppress zero sequence harmonics, usually by the use of a two-thirds pitch winding, will have negligible circulating currents when operated in parallel; therefore, it is often found practical to operate these types of generators with the neutral disconnect device closed. This simplifies the operating procedure and increases assurance that the system will be grounded at all times, because interlocking methods can be used.

It is sometimes desirable to operate with only one generator neutral disconnecting device closed at a time to eliminate any circulating harmonic or zero-sequence currents. In addition, this method provides control over the maximum ground fault current and simplifies ground relaying. When the generator whose neutral is grounded is to be shut down, another generator is grounded by means of its neutral disconnecting device before the main and neutral disconnecting device of the first one are opened. This method has some inherent safety considerations that must be recognized and addressed in order to ensure continual safe operation. The procedures required to permit only one disconnecting device to be closed with multiple sources generally do not permit the use of conventional interlocking methods to ensure that at least one neutral disconnecting device will be closed. Therefore, this method should only be used where strict supervision of operating procedures is assured.

When only one source is involved, but others are to be added to the station in the future, space should be allowed to add neutral switchgear when this becomes necessary.

#### **1.6.4 Creation of Stray Currents and Potentials**

If a current-carrying conductor, even though nominally at ground potential, is connected to earth at more than one location, part of the load current will flow through the earth because it is then in parallel with the grounded conductor. Since there is impedance in both the conductor and the earth, a voltage drop will occur both along the earth and the conductor. Most of the voltage drop in the earth will occur in the vicinity of the point of connection to earth, as explained in Chapter 4. Because of this nonlinear voltage drop in the earth, most of the earth will be at a different potential than the grounded conductor due to the load current flowing from this conductor to earth.

An equipment grounding conductor connected to the same electrode as the grounded load conductor will also have a potential difference from most of the earth due to the potential drop caused by the load current. In most instances the potential difference will be too low to present a shock hazard to persons or affect operation of conventional electrical

## 250.20 Alternating-Current Systems to Be Grounded

Alternating-current systems shall be grounded as provided for in 250.20(A), (B), (C), or (D). Other systems shall be permitted to be grounded. If such systems are grounded, they shall comply with the applicable provisions of this article.

FPN: An example of a system permitted to be grounded is a corner-grounded delta transformer connection. See 250.26(4) for conductor to be grounded.

**(A) Alternating-Current Systems of Less Than 50 Volts** Alternating-current systems of less than 50 volts shall be grounded under any of the following conditions:

- (1) Where supplied by transformers, if the transformer supply system exceeds 150 volts to ground
- (2) Where supplied by transformers, if the transformer supply system is ungrounded
- (3) Where installed as overhead conductors outside of buildings

**(B) Alternating-Current Systems of 50 Volts to 1000 Volts** Alternating-current systems of 50 volts to 1000 volts that supply premises wiring and premises wiring systems shall be grounded under any of the following conditions:

- (1) Where the system can be grounded so that the maximum voltage to ground on the ungrounded conductors does not exceed 150 volts

Exhibit 250.4 illustrates the grounding requirements of 250.20(B)(1) as applied to a 120-volt, single-phase, 2-wire system and to a 120/240-volt, single-phase, 3-wire system. The selection of which conductor is to be grounded is covered by 250.26.

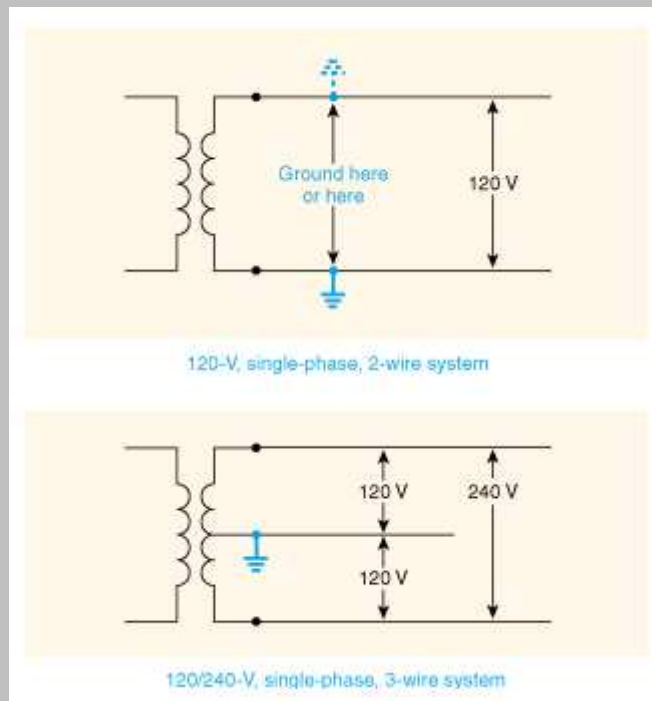

**Exhibit 250.4 Typical systems required to be grounded in accordance with 250.20(B)(1).  
The conductor to be grounded is in accordance with 250.26.**

- (2) Where the system is 3-phase, 4-wire, wye connected in which the neutral is used as a circuit conductor
- (3) Where the system is 3-phase, 4-wire, delta connected in which the midpoint of one phase winding is used as a circuit conductor

Exhibit 250.5 illustrates which conductor is required to be grounded for all wye systems if the neutral is used as a circuit conductor. Where the midpoint of one phase of a 3-phase, 4-wire delta system is used as a circuit conductor, it must be grounded and the high-leg conductor must be identified. See 250.20(B)(2) and 250.20(B)(3), as well as 250.26.

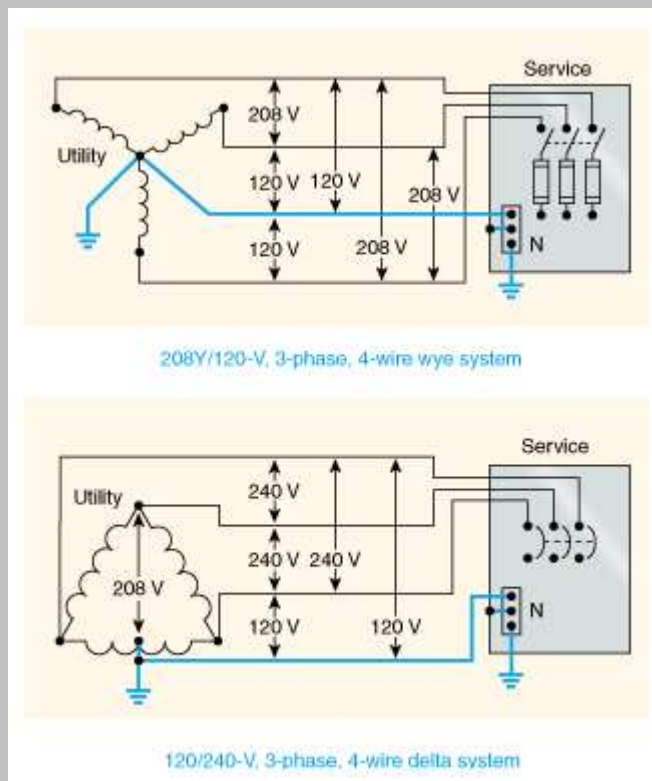

**Exhibit 250.5 Typical systems required to be grounded by 250.20(B)(2) and 250.20(B)(3).  
The conductor to be grounded is in accordance with 250.26.**

**(C) Alternating-Current Systems of 1 kV and Over** Alternating-current systems supplying mobile or portable equipment shall be grounded as specified in 250.188. Where supplying other than mobile or portable equipment, such systems shall be permitted to be grounded.

**(D) Separately Derived Systems** Separately derived systems, as covered in 250.20(A) or (B), shall be grounded as specified in 250.30.

Two of the most common sources of separately derived systems in premises wiring are transformers and generators. An autotransformer or step-down transformer that is part of

electrical equipment and that does not supply premises wiring is not the source of a separately derived system. See the definition of *premises wiring* in Article 100.

FPN No. 1: An alternate ac power source such as an on-site generator is not a separately derived system if the neutral is solidly interconnected to a service-supplied system neutral.

Exhibit 250.6 and Exhibit 250.7 depict a 208Y/120-volt, 3-phase, 4-wire electrical service supplying a service disconnecting means to a building. The system is fed through a transfer switch connected to a generator intended to provide power for an emergency or standby system.

In Exhibit 250.6, the neutral conductor from the generator to the load is not disconnected by the transfer switch. There is a direct electrical connection between the normal grounded system conductor (neutral) and the generator neutral through the neutral bus in the transfer switch, thereby grounding the generator neutral. Because the generator is grounded by connection to the normal system ground, it is not a separately derived system, and there are no requirements for grounding the neutral at the generator. Under these conditions, it is necessary to run an equipment grounding conductor from the service equipment to the 3-pole transfer switch and from the 3-pole transfer switch to the generator. This can be in the form of any of the items listed in 250.118.

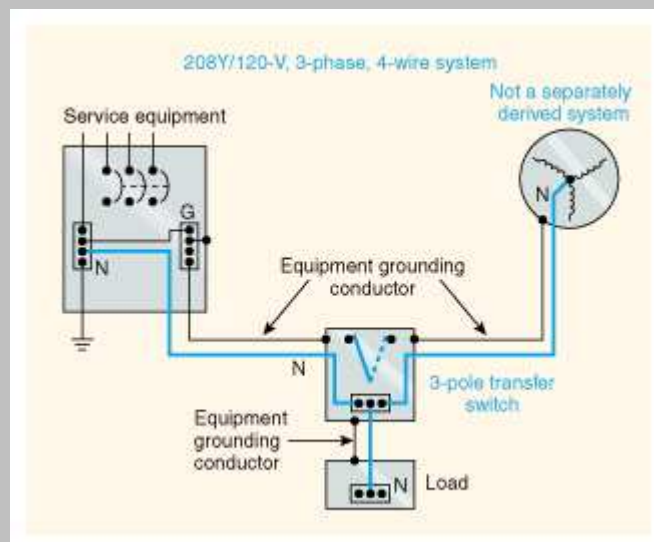

**Exhibit 250.6 A 208Y/120-volt, 3-phase, 4-wire system that has a direct electrical connection of the grounded circuit conductor (neutral) to the generator and is therefore not considered a separately derived system.**

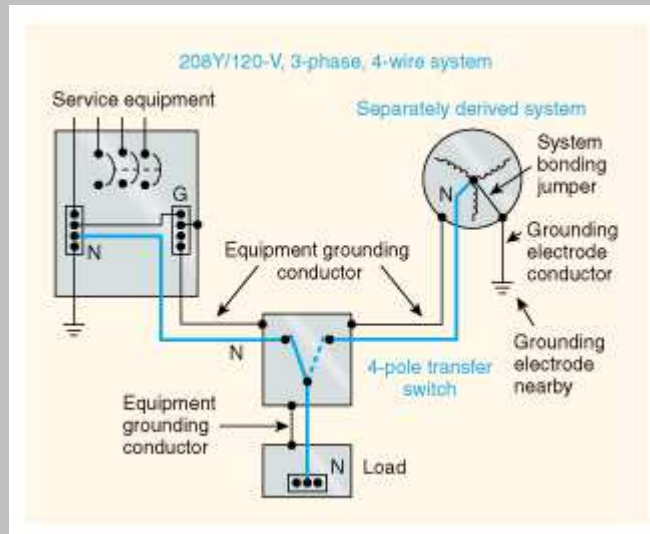

**Exhibit 250.7 A 208Y/120-volt, 3-phase, 4-wire system that does not have a direct electrical connection of the grounded circuit conductor (neutral) to the generator and is therefore considered a separately derived system.**

In Exhibit 250.7, the grounded conductor (neutral) is connected to the switching contacts of a 4-pole transfer switch. Therefore, the generator system does not have a direct electrical connection to the other supply system grounded conductor (neutral), and the system supplied by the generator is considered separately derived. This separately derived system (3-phase, 4-wire, wye-connected system that supplies line-to-neutral loads) is required to be grounded in accordance with 250.20(B) and 250.20(D). The methods for grounding the system are specified in 250.30(A).

Section 250.30(A)(1) requires separately derived systems to have a system bonding jumper connected between the generator frame and the grounded circuit conductor (neutral). The grounding electrode conductor from the generator is required to be connected to a grounding electrode. This conductor should be located as close to the generator as practicable, according to 250.30(A)(4). If the generator is in a building, the preferred grounding electrode is required to be one of the following, depending on which grounding electrode is closest to the generator location: (1) effectively grounded structural metal member or (2) the first 5 ft of water pipe into a building where the piping is effectively grounded. (The exception to 250.52(A)(1) permits the grounding connection to the water piping beyond the first 5 ft.) For buildings or structures in which the preferred electrodes are not available, the choice can be made from any of the grounding electrodes specified in 250.52(A)(3) through 250.52(A)(7).

FPN No. 2: For systems that are not separately derived and are not required to be grounded as specified in 250.30, see 445.13 for minimum size of conductors that must carry fault current.

**(E) Impedance Grounded Neutral Systems** Impedance grounded neutral systems shall be grounded in accordance with 250.36 or 250.186.

### **250.30 Grounding Separately Derived Alternating-Current Systems**

**(A) Grounded Systems** A separately derived ac system that is grounded shall comply with 250.30(A)(1) through (A)(8). A grounding connection shall not be made to any grounded circuit conductor on the load side of the point of grounding of the separately derived system except as otherwise permitted in this article.

FPN: See 250.32 for connections at separate buildings or structures, and 250.142 for use of the grounded circuit conductor for grounding equipment.

*Exception: Impedance grounded neutral system grounding connections shall be made as specified in 250.36 or 250.186.*

Section 250.30(A) provides the requirements for bonding and grounding the separately derived systems described in 250.20(D). A *separately derived system* is defined in Article 100 as a premises wiring system in which power is derived from a battery, a solar photovoltaic system, a generator, a transformer, or converter windings. It has no direct electrical connection, including a solidly connected grounded circuit conductor, to supply conductors originating in another system.

The requirements of 250.30 are commonly applied to 480-volt transformers that transform a 480-volt supply to a 208Y/120-volt system for lighting and appliance loads. These requirements provide for a low-impedance path to ground so that line-to-ground faults on circuits supplied by the transformer result in a sufficient amount of current to operate the overcurrent devices. These requirements also apply to generators or systems that are derived from converter windings, although these systems do not have the same wide use as separately derived systems that are derived from transformers.

**(1) System Bonding Jumper** An unspliced system bonding jumper in compliance with 250.28(A) through (D) that is sized based on the derived phase conductors shall be used to connect the equipment grounding conductors of the separately derived system to the grounded conductor. This connection shall be made at any single point on the separately derived system from the source to the first system disconnecting means or overcurrent device, or it shall be made at the source of a separately derived system that has no disconnecting means or overcurrent devices.

Where a separately derived system provides a grounded conductor, a system bonding jumper must be installed to connect the equipment grounding conductors to the grounded conductor. Equipment grounding conductors are connected to the grounding electrode system by the grounding electrode conductor. The system bonding jumper is sized according to 250.28(D) and may be located at any point between the source terminals (transformer, generator, etc.) and the first disconnecting means or overcurrent device. See the commentary following 250.28(D) for further information on sizing the system bonding jumper.

*Exception No. 1: For separately derived systems that are dual fed (double ended) in a common enclosure or grouped together in separate enclosures and employing a secondary tie, a single system bonding jumper connection to the tie point of the grounded circuit conductors from each power source shall be permitted.*

*Exception No. 2: A system bonding jumper at both the source and the first disconnecting means*

*shall be permitted where doing so does not establish a parallel path for the grounded conductor. Where a grounded conductor is used in this manner, it shall not be smaller than the size specified for the system bonding jumper but shall not be required to be larger than the ungrounded conductor(s). For the purposes of this exception, connection through the earth shall not be considered as providing a parallel path.*

*Exception No. 3: The size of the system bonding jumper for a system that supplies a Class 1, Class 2, or Class 3 circuit, and is derived from a transformer rated not more than 1000 volt-amperes, shall not be smaller than the derived phase conductors and shall not be smaller than 14 AWG copper or 12 AWG aluminum.*

Section 250.30(A)(1) requires the system bonding jumper to be not smaller than the sizes given in Table 250.66, that is, not smaller than 8 AWG copper. Exception No. 3 to 250.30(A)(1) permits a system bonding jumper for a Class 1, Class 2, or Class 3 circuit to be not smaller than 14 AWG copper or 12 AWG aluminum.

**(2) Equipment Bonding Jumper Size** Where a bonding jumper of the wire type is run with the derived phase conductors from the source of a separately derived system to the first disconnecting means, it shall be sized in accordance with 250.102(C), based on the size of the derived phase conductors.

**(3) Grounding Electrode Conductor, Single Separately Derived System** A grounding electrode conductor for a single separately derived system shall be sized in accordance with 250.66 for the derived phase conductors and shall be used to connect the grounded conductor of the derived system to the grounding electrode as specified in 250.30(A)(7). This connection shall be made at the same point on the separately derived system where the system bonding jumper is installed.

*Exception No. 1: Where the system bonding jumper specified in 250.30(A)(1) is a wire or busbar, it shall be permitted to connect the grounding electrode conductor to the equipment grounding terminal, bar, or bus, provided the equipment grounding terminal, bar, or bus is of sufficient size for the separately derived system.*

*Exception No. 2: Where a separately derived system originates in listed equipment suitable as service equipment, the grounding electrode conductor from the service or feeder equipment to the grounding electrode shall be permitted as the grounding electrode conductor for the separately derived system, provided the grounding electrode conductor is of sufficient size for the separately derived system. Where the equipment ground bus internal to the equipment is not smaller than the required grounding electrode conductor for the separately derived system, the grounding electrode connection for the separately derived system shall be permitted to be made to the bus.*

*Exception No. 3: A grounding electrode conductor shall not be required for a system that supplies a Class 1, Class 2, or Class 3 circuit and is derived from a transformer rated not more than 1000 volt-amperes, provided the grounded conductor is bonded to the transformer frame or enclosure by a jumper sized in accordance with 250.30(A)(1), Exception No. 3, and the transformer frame or enclosure is grounded by one of the means specified in 250.134.*



If a separately derived system is required to be grounded, the conductor to be grounded is allowed to be connected to the grounding electrode system at any location between the source terminals (transformer, generator, etc.) and the first disconnecting means or overcurrent device. The location of the grounding electrode conductor connection to the grounded conductor must be at the same point as where the bonding jumper is connected to the grounded conductor. By establishing a common point of connection, normal neutral current will be carried only on the system grounded conductor. Metal raceways, piping systems, and structural steel must not provide a parallel circuit for neutral current. Exhibits 250.13 and 250.14 illustrate examples of grounding electrode connections for separately derived systems.

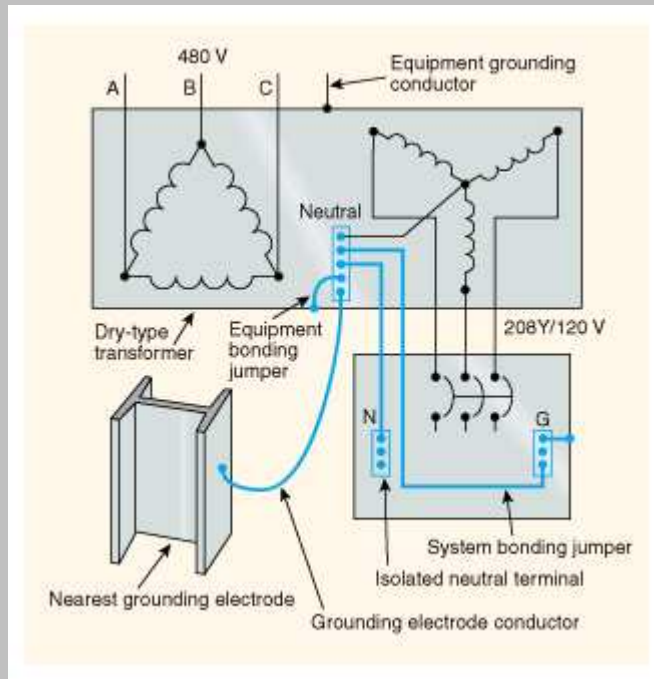

**Exhibit 250.13 A grounding arrangement for a separately derived system in which the grounding electrode conductor connection is made at the transformer.**

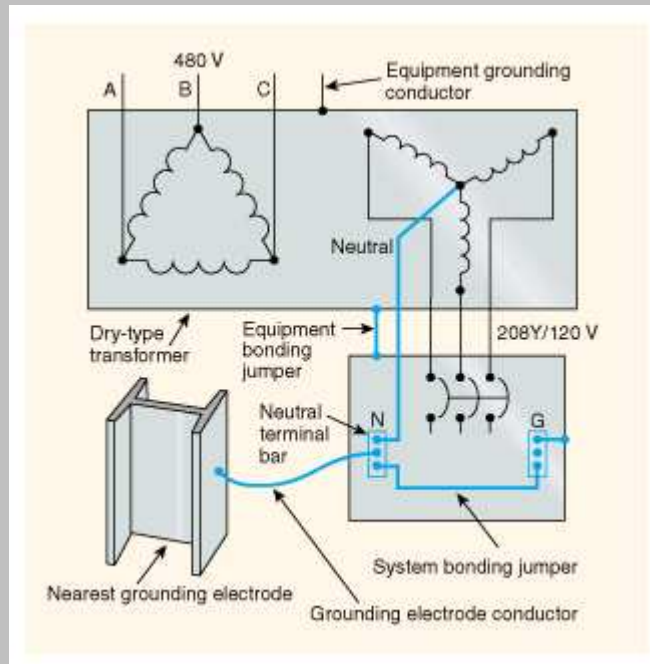

**Exhibit 250.14 A grounding arrangement for a separately derived system in which the grounding electrode conductor connection is made at the first disconnecting means.**

**(4) Grounding Electrode Conductor, Multiple Separately Derived Systems** Where more than one separately derived system is installed, it shall be permissible to connect a tap from each separately derived system to a common grounding electrode conductor. Each tap conductor shall connect the grounded conductor of the separately derived system to the common grounding electrode conductor. The grounding electrode conductors and taps shall comply with 250.30(A)(4)(a) through (A)(4)(c).

*Exception No. 1: Where the system bonding jumper specified in 250.30(A)(1) is a wire or busbar, it shall be permitted to connect the grounding electrode conductor to the equipment grounding terminal, bar, or bus, provided the equipment grounding terminal, bar, or bus is of sufficient size for the separately derived system.*

*Exception No. 2: A grounding electrode conductor shall not be required for a system that supplies a Class 1, Class 2, or Class 3 circuit and is derived from a transformer rated not more than 1000 volt-amperes, provided the system grounded conductor is bonded to the transformer frame or enclosure by a jumper sized in accordance with 250.30(A)(1), Exception No. 3 and the transformer frame or enclosure is grounded by one of the means specified in 250.134.*

- (a) **Common Grounding Electrode Conductor Size.** The common grounding electrode conductor shall not be smaller than 3/0 AWG copper or 250 kcmil aluminum.
- (b) **Tap Conductor Size.** Each tap conductor shall be sized in accordance with 250.66 based on the derived phase conductors of the separately derived system it serves.

*Exception: Where a separately derived system originates in listed equipment suitable as service equipment, the grounding electrode conductor from the service or feeder equipment to the*

*grounding electrode shall be permitted as the grounding electrode conductor for the separately derived system, provided the grounding electrode conductor is of sufficient size for the separately derived system. Where the equipment ground bus internal to the equipment is not smaller than the required grounding electrode conductor for the separately derived system, the grounding electrode connection for the separately derived system shall be permitted to be made to the bus.*

(3) Connections. All tap connections to the common grounding electrode conductor shall be made at an accessible location by one of the following methods:

(1) A listed connector.

(2) Listed connections to aluminum or copper busbars not less than 6 mm × 50 mm ( <sup>1</sup>/<sub>4</sub> in. × 2 in.). Where aluminum busbars are used, the installation shall comply with 250.64(A).

(3) By the exothermic welding process.

Tap conductors shall be connected to the common grounding electrode conductor in such a manner that the common grounding electrode conductor remains without a splice or joint.

A common grounding electrode conductor serving several separately derived systems is permitted instead of installing separate individual grounding electrode conductors from each separately derived system to the grounding electrode system. A tapped grounding electrode conductor is installed from the common grounding electrode conductor to the point of connection to the individual separately derived system grounded conductor. This tap is sized from Table 250.66 based on the size of the ungrounded conductors for that individual separately derived system.

The sizing requirement for the common grounding electrode conductor was revised for the 2005 *Code*. So that the grounding electrode conductor always has sufficient size to accommodate the multiple separately derived systems that it serves, the minimum size for this conductor is now 3/0 AWG copper or 250-kcmil aluminum. Note that this new minimum size for the common grounding electrode conductor correlates with the maximum size grounding electrode conductor required by Table 250.66; therefore, the 3/0 AWG copper or 250-kcmil aluminum becomes the maximum size required for the common grounding electrode conductor. The sizing requirement for the common grounding electrode conductor is specified in 250.30(A)(4)(a), and the sizing requirement for the individual taps to the common grounding electrode conductor is specified in 250.30(A)(4)(b). The rules covering the method of connection of the tap conductor to the common grounding electrode conductor are specified in 250.30(A)(4)(c). The following example, together with Exhibit 250.15, illustrates this new permitted installation method.

### **Example**

A large post-and-beam loft-type building is being renovated for use as an office building. The building is being furnished with four 45-kVA, 480 to 120/208-volt, 3-phase, 4-wire, wye-connected transformers. Each transformer secondary supplies an adjacent 150-ampere

main circuit breaker panelboard using 1/0 AWG, Type THHN copper conductors. The transformers are strategically placed throughout the building to facilitate efficient distribution. Because the building contains no effectively grounded structural steel, each transformer secondary must be grounded to the water service electrode within the first 5 ft of entry into the building. A common grounding electrode conductor has been selected as the method to connect all the transformers to the grounding electrode system.

What is the minimum-size common grounding electrode conductor that must be used to connect the four transformers to the grounding electrode system? What is the minimum-size grounding electrode conductor to connect each of the four transformers to the common grounding electrode conductor?

### **Solution**

#### **STEP 1.**

Determine the minimum size for the common grounding electrode conductor. In accordance with 250.30(A)(4)(a), the minimum size required is 3/0 copper or 250-kcmil aluminum. No calculation is necessary, and the common grounding electrode conductor does not have to be sized larger than specified by this requirement. Additional transformers installed in the building can be connected to this common grounding electrode conductor, and no increase in its size is required.

#### **STEP 2.**

Determine the size of each individual grounding electrode tap conductor for each of the separately derived systems. According to Table 250.66, a 1/0 AWG copper derived phase conductor requires a conductor not smaller than 6 AWG copper for each transformer grounding electrode tap conductor. This individual grounding electrode conductor will be used as the permitted tap conductor and will run from the conductor to be grounded of each separately derived system to a connection point located on the common grounding electrode conductor. This conductor is labeled "Conductor B" in Exhibit 250.15.

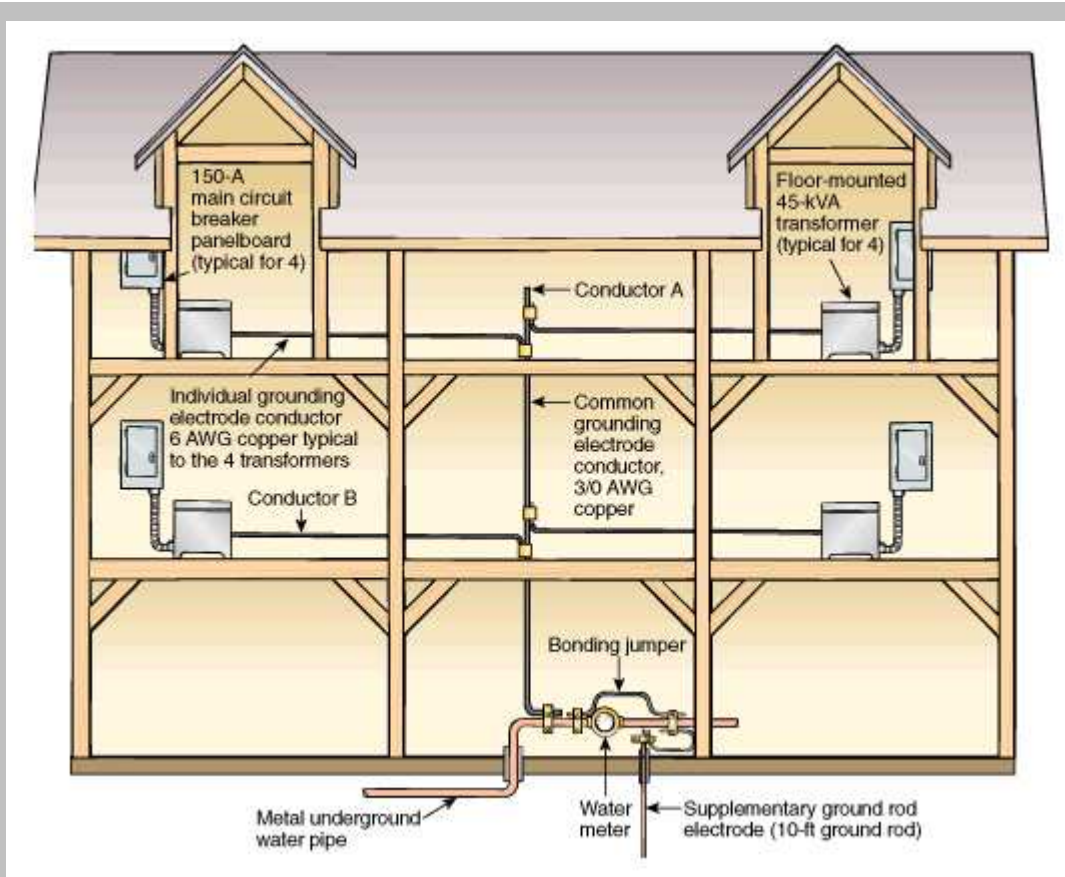

**Exhibit 250.15** The grounding arrangement for multiple separately derived systems using taps from a common grounding electrode conductor, according to 250.30(A)(4)(a) and 250.30(A)(4)(b).

**(5) Installation** The installation of all grounding electrode conductors shall comply with 250.64(A), (B), (C), and (E).

**(6) Bonding** Structural steel and metal piping shall be bonded in accordance with 250.104(D).

**(7) Grounding Electrode** The grounding electrode shall be as near as practicable to and preferably in the same area as the grounding electrode conductor connection to the system. The grounding electrode shall be the nearest one of the following:

- (1) Metal water pipe grounding electrode as specified in 250.52(A)(1)
- (2) Structural metal grounding electrode as specified in 250.52(A)(2)

*Exception No. 1: Any of the other electrodes identified in 250.52(A) shall be used where the electrodes specified by 250.30(A)(7) are not available.*

*Exception No. 2 to (1) and (2): Where a separately derived system originates in listed equipment suitable for use as service equipment, the grounding electrode used for the service or feeder equipment shall be permitted as the grounding electrode for the separately derived system.*

FPN: See 250.104(D) for bonding requirements of interior metal water piping in the area served by separately derived systems.

Section 250.30(A)(7) requires that the grounding electrode be as near as is practicable to the grounding conductor connection to the system to minimize the impedance to ground. If an effectively grounded structural metal member of the building structure or an effectively grounded metal water pipe is available nearby, 250.30(A)(7) requires that it be used as the grounding electrode. For example, where a transformer is installed on the fiftieth floor, the grounding electrode conductor is not required to be run to the service grounding electrode system. However, where an effectively grounded metal water pipe is used as an electrode for a separately derived system, 250.52(A) specifies that only the first 5 ft of water piping entering the building can be used as a grounding electrode. Therefore, the grounding electrode conductor connection to the metal water piping must be made at some point on this first 5 ft of piping.

Concern over the use of nonmetallic piping or fittings is the basis for the "within 5 ft" requirement. Where the piping system is located in an industrial or commercial building and is serviced only by qualified persons and the entire length that will be used as an electrode is exposed, the connection may be made at any point on the piping system.

The practice of grounding the secondary of an isolating transformer to a ground rod or running the grounding electrode conductor back to the service ground (usually to reduce electrical noise on data processing systems) is not permitted where either of the electrodes covered in item (1) or item (2) of 250.30(A)(7) is available. However, an isolation transformer that is part of a listed power supply for a data processing room is not required to be grounded in accordance with 250.30(A)(7), but it must be grounded in accordance with the manufacturer's instructions.

Exhibit 250.13 and Exhibit 250.14 are typical wiring diagrams for dry-type transformers supplied from a 480-volt, 3-phase feeder to derive a 208Y/120-volt or 480Y/277-volt secondary. As indicated in 250.30(A)(1), the bonding jumper connection is required to be sized according to 250.28(D). In Exhibit 250.13, this connection is made at the source of the separately derived system, in the transformer enclosure. In Exhibit 250.14, the bonding jumper connection is made at the first disconnecting means. With the grounding electrode conductor, the bonding jumper, and the bonding of the grounded circuit conductor (neutral) connected as shown, line-to-ground fault currents are able to return to the supply source through a short, low-impedance path. A path of lower impedance is provided that facilitates the operation of overcurrent devices, in accordance with 250.4(A)(5). The grounding electrode conductor from the secondary grounded circuit conductor is sized according to Table 250.66.

**(8) Grounded Conductor** Where a grounded conductor is installed and the system bonding jumper is not located at the source of the separately derived system, 250.30(A)(8)(a), (A)(8)(b), and (A)(8)(c) shall apply.

- (a) **Routing and Sizing.** This conductor shall be routed with the derived phase conductors and shall not be smaller than the required grounding electrode conductor specified in Table 250.66 but shall not be required to be larger than the largest ungrounded derived phase

conductor. In addition, for phase conductors larger than 1100 kcmil copper or 1750 kcmil aluminum, the grounded conductor shall not be smaller than 12 1/2 percent of the area of the largest derived phase conductor. The grounded conductor of a 3-phase, 3-wire delta system shall have an ampacity not less than that of the ungrounded conductors.

- (b) **Parallel Conductors.** Where the derived phase conductors are installed in parallel, the size of the grounded conductor shall be based on the total circular mil area of the parallel conductors, as indicated in this section. Where installed in two or more raceways, the size of the grounded conductor in each raceway shall be based on the size of the ungrounded conductors in the raceway but not smaller than 1/0 AWG.

FPN: See 310.4 for grounded conductors connected in parallel.

- (c) **Impedance Grounded System.** The grounded conductor of an impedance grounded neutral system shall be installed in accordance with 250.36 or 250.186.

**(B) Ungrounded Systems** The equipment of an ungrounded separately derived system shall be grounded as specified in 250.30(B)(1) and (B)(2).

**(1) Grounding Electrode Conductor** A grounding electrode conductor, sized in accordance with 250.66 for the derived phase conductors, shall be used to connect the metal enclosures of the derived system to the grounding electrode as specified in 250.30(B)(2). This connection shall be made at any point on the separately derived system from the source to the first system disconnecting means.

For ungrounded separately derived systems, a grounding electrode conductor is required to be connected to the metal enclosure of the system disconnecting means. The grounding electrode conductor is sized from Table 250.66 based on the largest ungrounded supply conductor. This connection establishes a reference to ground for all exposed non-current-carrying metal equipment supplied from the ungrounded system. The equipment grounding conductors of circuits supplied from the ungrounded system are connected to ground via this grounding electrode conductor connection.

**(2) Grounding Electrode** Except as permitted by 250.34 for portable and vehicle-mounted generators, the grounding electrode shall comply with 250.30(A)(7).

### **250.36 High-Impedance Grounded Neutral Systems**

High-impedance grounded neutral systems in which a grounding impedance, usually a resistor, limits the ground-fault current to a low value shall be permitted for 3-phase ac systems of 480 volts to 1000 volts where all the following conditions are met:

- (1) The conditions of maintenance and supervision ensure that only qualified persons service the installation.
- (2) Continuity of power is required.
- (3) Ground detectors are installed on the system.
- (4) Line-to-neutral loads are not served.

Section 250.36 covers high-impedance grounded neutral systems of 480 to 1000 volts. Systems rated over 1000 volts are covered in 250.186. For information on the differences between solidly grounded systems and high-impedance grounded neutral systems, see "Grounding for Emergency and Standby Power Systems," by Robert B. West, *IEEE Transactions on Industry Applications*, Vol. IA-15, No. 2, March/April 1979.

As the schematic diagram in Exhibit 250.20 shows, a high-impedance grounded neutral system is designed to minimize the amount of fault current during a ground fault. The grounding impedance is usually selected to limit fault current to a value that is slightly greater than or equal to the capacitive charging current. This system is used where continuity of power is required. Therefore, a ground fault results in an alarm condition rather than in the tripping of a circuit breaker, which allows a safe and orderly shutdown of a process in which a non-orderly shutdown can introduce additional or increased hazards.

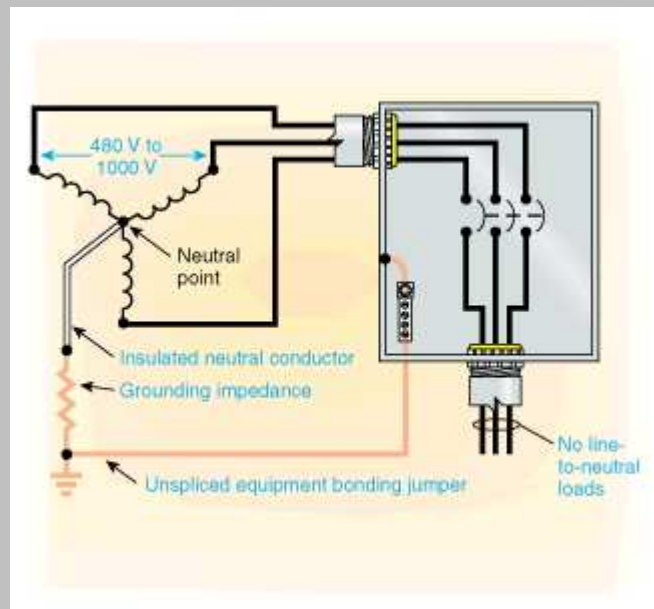

**Exhibit 250.20 Schematic diagram of a high-impedance grounded neutral system.**

High-impedance grounded neutral systems shall comply with the provisions of 250.36(A) through (G).

**(A) Grounding Impedance Location** The grounding impedance shall be installed between the grounding electrode conductor and the system neutral. Where a neutral is not available, the grounding impedance shall be installed between the grounding electrode conductor and the neutral derived from a grounding transformer.

**(B) Neutral Conductor** The neutral conductor from the neutral point of the transformer or generator to its connection point to the grounding impedance shall be fully insulated.

The neutral conductor shall have an ampacity of not less than the maximum current rating of the grounding impedance. In no case shall the neutral conductor be smaller than 8 AWG copper or 6 AWG aluminum or copper-clad aluminum.



The current through the neutral conductor is limited by the grounding impedance. Therefore, the neutral conductor is not required to be sized to carry high-fault current. The neutral conductor cannot be smaller than 8 AWG copper or 6 AWG aluminum.

**(C) System Neutral Connection** The system neutral conductor shall not be connected to ground except through the grounding impedance.

FPN: The impedance is normally selected to limit the ground-fault current to a value slightly greater than or equal to the capacitive charging current of the system. This value of impedance will also limit transient overvoltages to safe values. For guidance, refer to criteria for limiting transient overvoltages in ANSI/IEEE 142-1991, *Recommended Practice for Grounding of Industrial and Commercial Power Systems*.

Additional information can be found in "Charging Current Data for Guesswork-Free Design of High-Resistance Grounded Systems," by D. S. Baker, *IEEE Transactions on Industry Applications*, Vol. IA-15, No. 2, March/April 1979; and "High-Resistance Grounding," by Baldwin Bridger, Jr., *IEEE Transactions on Industry Applications*, Vol. IA-19, No. 1, January/February 1983.

**(D) Neutral Conductor Routing** The conductor connecting the neutral point of the transformer or generator to the grounding impedance shall be permitted to be installed in a separate raceway. It shall not be required to run this conductor with the phase conductors to the first system disconnecting means or overcurrent device.

**(E) Equipment Bonding Jumper** The equipment bonding jumper (the connection between the equipment grounding conductors and the grounding impedance) shall be an unspliced conductor run from the first system disconnecting means or overcurrent device to the grounded side of the grounding impedance.

**(F) Grounding Electrode Conductor Location** The grounding electrode conductor shall be attached at any point from the grounded side of the grounding impedance to the equipment grounding connection at the service equipment or first system disconnecting means.

**(G) Equipment Bonding Jumper Size** The equipment bonding jumper shall be sized in accordance with (1) or (2) as follows:

- (1) Where the grounding electrode conductor connection is made at the grounding impedance, the equipment bonding jumper shall be sized in accordance with 250.66, based on the size of the service entrance conductors for a service or the derived phase conductors for a separately derived system.
- (2) Where the grounding electrode conductor is connected at the first system disconnecting means or overcurrent device, the equipment bonding jumper shall be sized the same as the neutral conductor in 250.36(B).

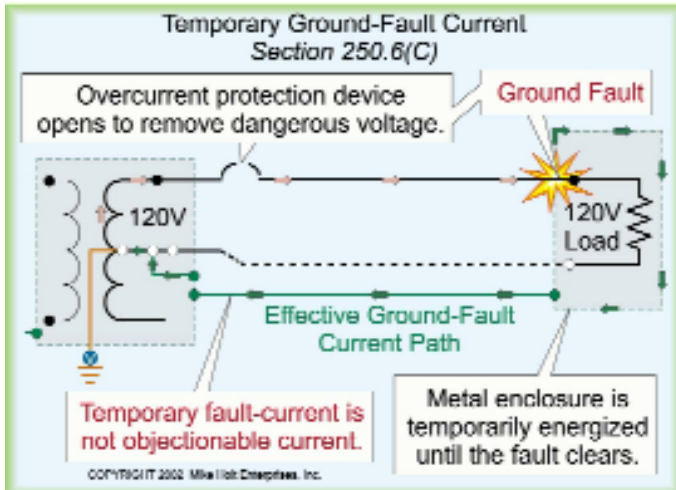

Figure 250-44

pendent grounding system. This practice is very dangerous and violates the *NEC* because the earth will not provide the low-impedance path necessary to clear a ground fault [250.4(A)(5)]. See 250.54 for the proper application of a supplementary electrode and 250.96(D) and 250.146(D) for the requirements of isolated equipment grounding (bonding) conductors for sensitive electronic equipment. Figure 250-46

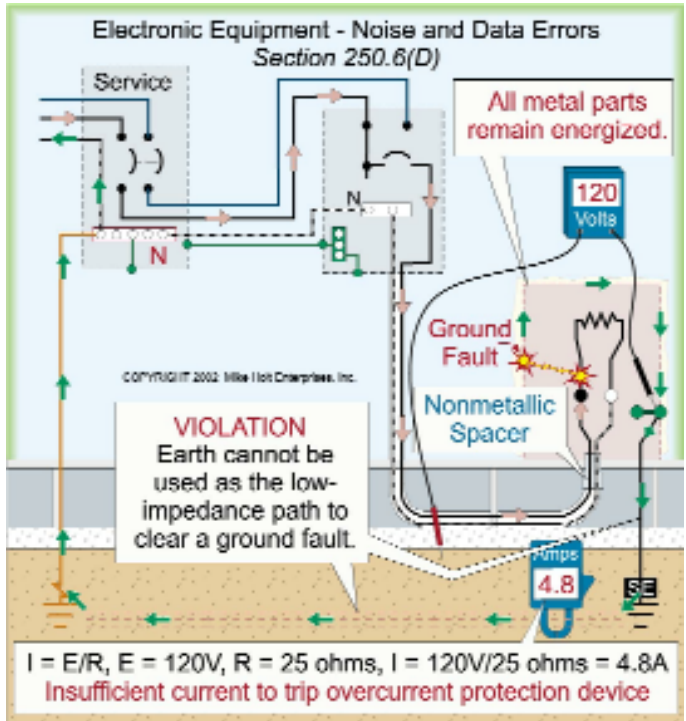

Figure 250-46

### 250.8 Termination of Grounding and Bonding Conductors



Equipment grounding (bonding) conductors, grounding electrode conductors and bonding jumpers shall terminate by exothermic welding, listed pressure connectors of the set screw or compression type, listed clamps, or other listed fittings. Sheet-metal screws shall not be used for the termination of grounding (or bonding) conductors. Figure 250-47

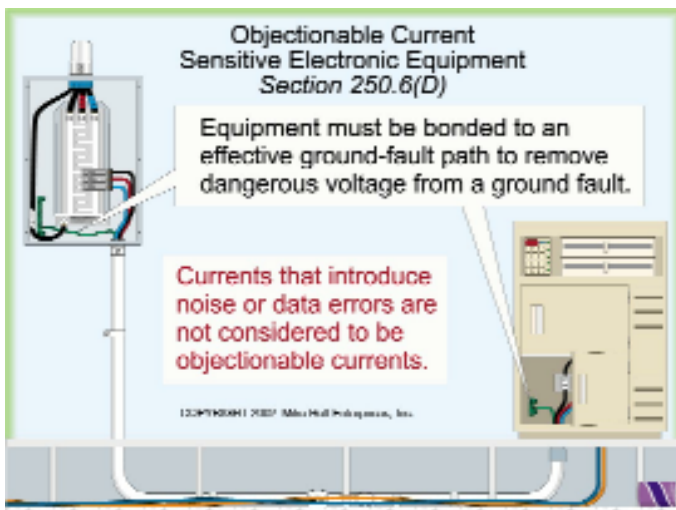

Figure 250-45

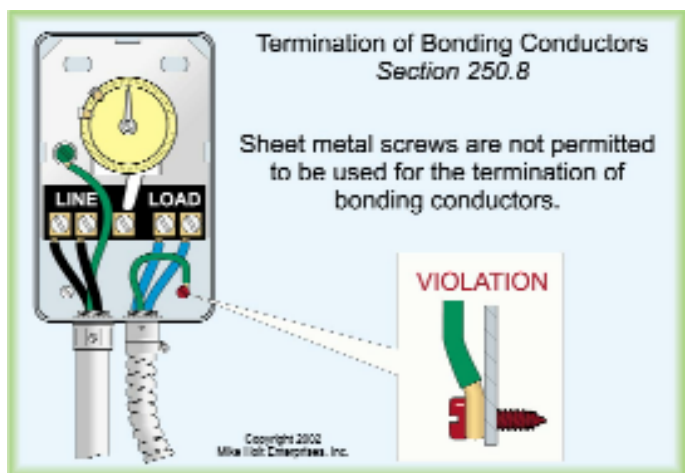

Figure 250-47

### 250.10 Protection of Grounding Fittings

Ground clamps and other grounding fittings shall be protected from physical damage by:

- (1) Locating the grounding fitting where they are not likely to be damaged
- (2) Enclosing the grounding fittings in metal, wood, or equivalent protective covering

**AUTHOR'S COMMENT:** Grounding fittings are permitted to be buried or encased in concrete if installed in accordance with 250.53(G), 250.68(A) Ex. and 250.70.

### 250.12 Clean Surface

Nonconductive coatings such as paint, lacquer and enamel shall be removed on equipment to be grounded or bonded to ensure good electrical continuity, or the termination fittings shall be designed so as to make such removal unnecessary [250.53(A) and 250.96(A)].

**AUTHOR'S COMMENT:** Some feel that "tarnish" on copper water pipe should be removed before making a grounding termination. This is a judgment call by the AHJ.

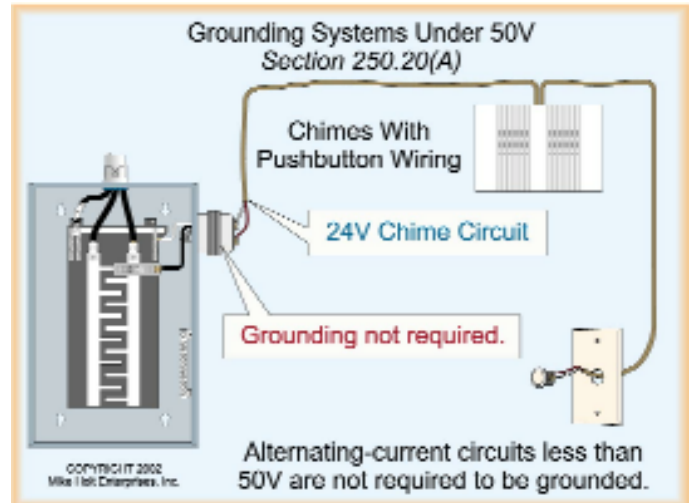

Figure 250-48

to earth in accordance with 250.4(A)(1) and 250.30(A)(1).

Such systems include: Figure 250-49

- 120V or 120/240V single-phase systems
- 208Y/120V or 480Y/277V, 4-wire, 3-phase, wye-connected systems
- 120/240V 4-wire, 3-phase, delta-connected systems

**AUTHOR'S COMMENT:** Other power supply systems, such as a corner-grounded delta-connected system, are permitted to be grounded [250.26(4)], but this is beyond the scope of this book.

## Part II. System and Equipment Grounding

### 250.20 Alternating-Current Systems to be Grounded

System (power supply) grounding is the intentional connection of one terminal of a power supply to the earth for the purpose of stabilizing the phase-to-earth voltage during normal operation [250.4(A)(1)].

**(A) AC Circuits of Less than 50V.** Alternating-current circuits supplied from a transformer that operate at less than 50V are not required to be grounded unless:

- (1) The primary is supplied from a 277V or 480V circuit.
- (2) The primary is supplied from an ungrounded power supply.

**AUTHOR'S COMMENT:** Typically, circuits operating at less than 50V are not grounded because they are not supplied from a 277V or 480V system, nor are they supplied from an ungrounded system. Figure 250-48

**(B) AC Systems Over 50V.** Alternating-current systems over 50V that require a grounded (neutral) conductor shall have the grounded neutral terminal of the power supply grounded

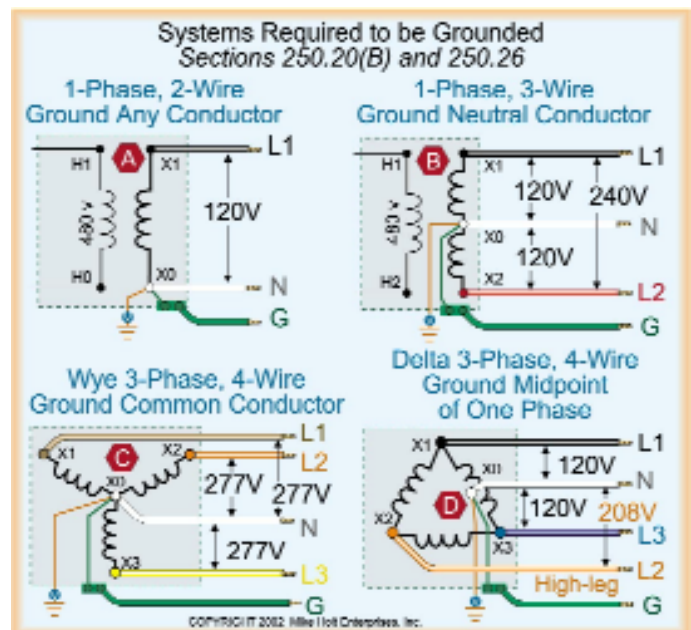

Figure 250-49

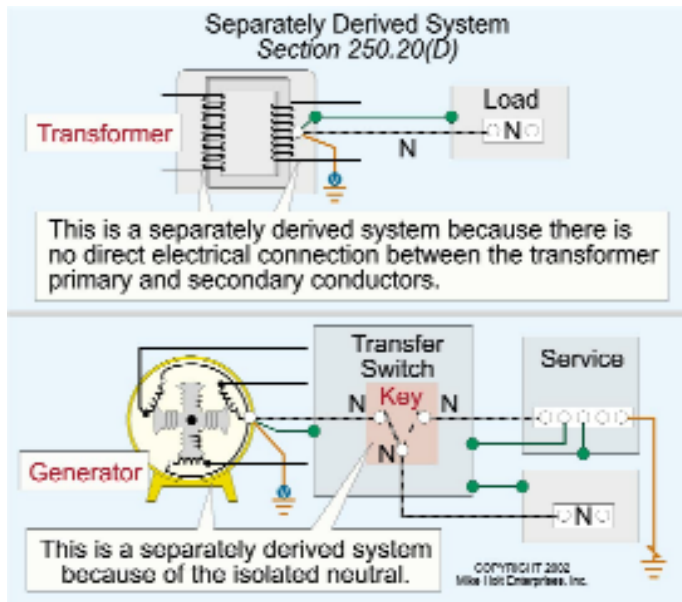

Figure 250-50

**(D) Separately Derived Systems.** Separately derived systems, which are required to be grounded by 250.20(A) or (B), shall be grounded (and bonded) in accordance with the requirements contained in 250.30.

**AUTHOR'S COMMENT:** According to Article 100, a separately derived system is a premises wiring system that has no direct electrical connection between the systems, including the grounded (neutral) conductor. Transformers are typically separately derived because the primary and secondary conductors are electrically isolated from each other. Generators that supply a transfer switch that opens the grounded (neutral) conductor are also separately derived. Figure 250-50

**FPN 1:** A generator is not a separately derived system if the grounded (neutral) conductor from the generator is solidly connected to the supply system grounded (neutral) conductor. In other words, if the transfer switch does not open the neutral conductor, then the generator will not be a separately derived system. Figure 250-51

**AUTHOR'S COMMENT:** This fine print note points out that when a generator is not a separately derived system, the grounding and bonding requirements contained in 250.30 do not apply and a neutral-to-case connection shall not be made at the generator [250.6(A) and 250.142].

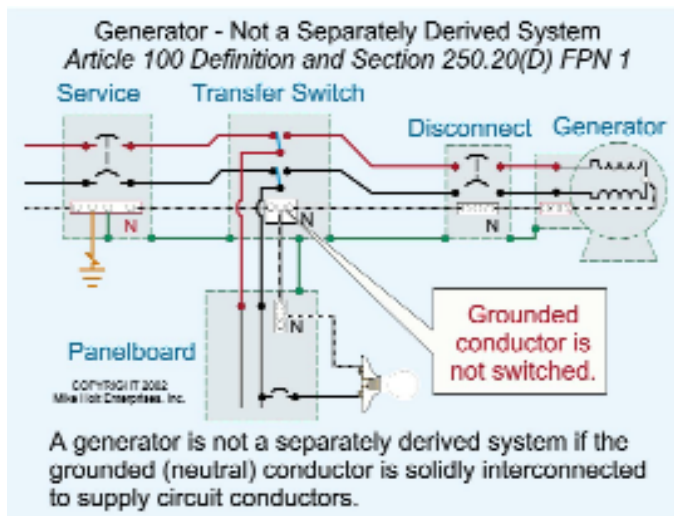

Figure 250-51

**FPN 2:** If the generator transfer switch does not open the grounded (neutral) conductor, then the grounded (neutral) conductor will be required to carry fault current back to the generator. Under this condition, the grounded (neutral) conductor shall be sized no smaller than required for the unbalanced load by 220.22 and in addition, it shall be sized no smaller than required by 250.24(B) [445.13]. Figure 250-52

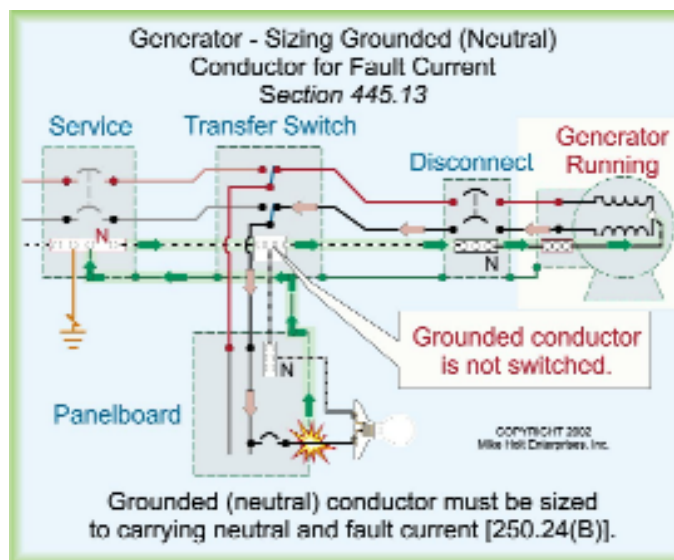

Figure 250-52



### 250.24 Grounding and Bonding at Service Equipment

The metal parts of electrical equipment shall be grounded to earth to protect persons from electric shock and to protect property from fires by limiting voltage on the metal parts from lightning [250.4(A)(2)].



(A) **Grounding.** Services supplied from a grounded utility transformer shall have the grounded (neutral) conductor grounded to any of the following grounding electrodes:

- Metal Underground Water Pipe [250.52(A)(1)]
- Effectively Grounded Metal Frame of the Building or Structure [250.52(A)(2)]
- Concrete-Encased Grounding Electrode [250.52(A)(3)]
- Ground Ring [250.52(A)(4)]

Where none of the above grounding electrodes are available, then one or more of the following grounding electrodes shall be installed:

- Ground Rod [250.52(A)(5)]
- Grounding Plate Electrodes 250.52(A)(6)]
- Other Local Metal Underground Systems or Structures [250.52(A)(7)]

**AUTHOR'S COMMENT:** The grounding of the grounded (neutral) conductor to earth at service equipment is intended to help the utility limit the voltage imposed by lightning, line surges, or unintentional contact with higher-voltage lines by shunting potentially dangerous energy into the earth. In addition, grounding of the grounded (neutral) conductor to earth helps the electric utility clear high-voltage ground faults when they occur.

(1) **Accessible Location.** A grounding electrode conductor shall connect the grounded (neutral) conductor at service equipment to the grounding electrode. This connection shall be at any accessible location, from the load end of the service drop or service lateral, up to and including the service disconnecting means. Figure 250-53

**AUTHOR'S COMMENT:** Some inspectors require the grounding electrode conductor to terminate to the grounded (neutral) conductor at the meter enclosure and others require this connection at the service disconnect. However, the Code allows this grounding connection at either the meter enclosure or the service disconnect.

(4) **Main Bonding Jumper.** The grounding electrode conductor can terminate to the equipment grounding terminal, if the equipment grounding terminal is bonded to the service equipment enclosure [250.28].

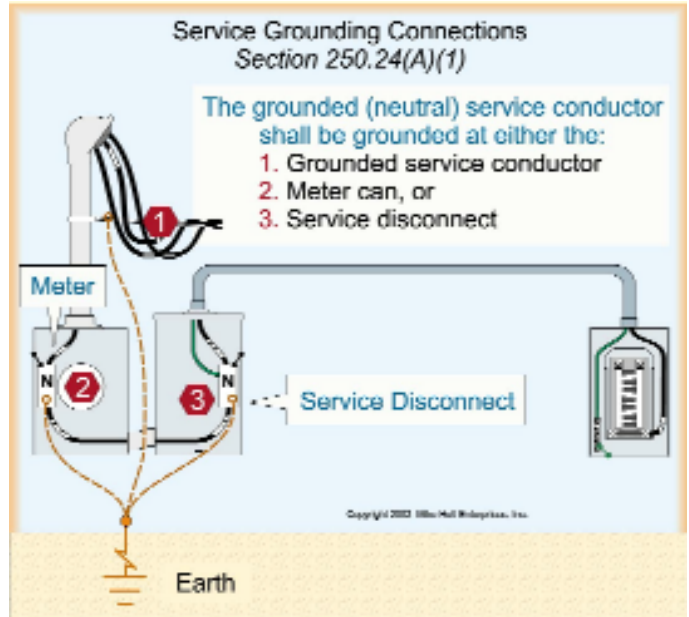

Figure 250-53

(5) **Load-Side Bonding Connections.** A neutral-to-case bond shall not be made on the load side of the service disconnecting means, except as permitted in 250.30(A)(1) for separately derived systems, 250.32(B)(2) for separate buildings, or 250.142(B) Ex. 2 for meter enclosures. Figure 250-54

**AUTHOR'S COMMENT:** If a neutral-to-case bond is made on the load side of service equipment, objectionable neutral current will flow on conductive metal parts of electrical equipment in violation of 250.6(A) [250.142]. Objectionable current on metal parts of electrical equipment can create a condition where

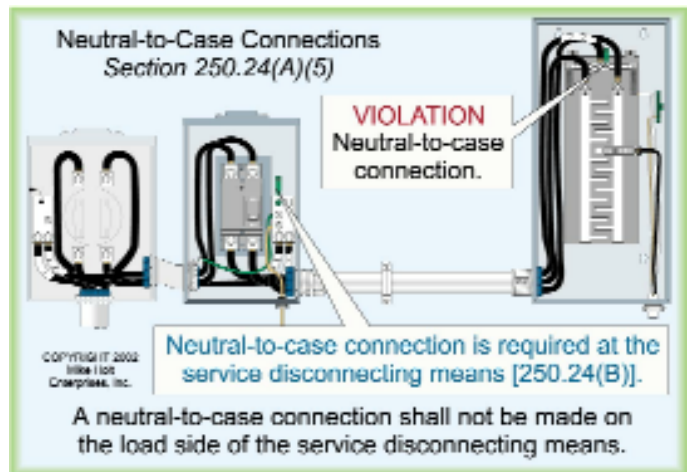

Figure 250-54

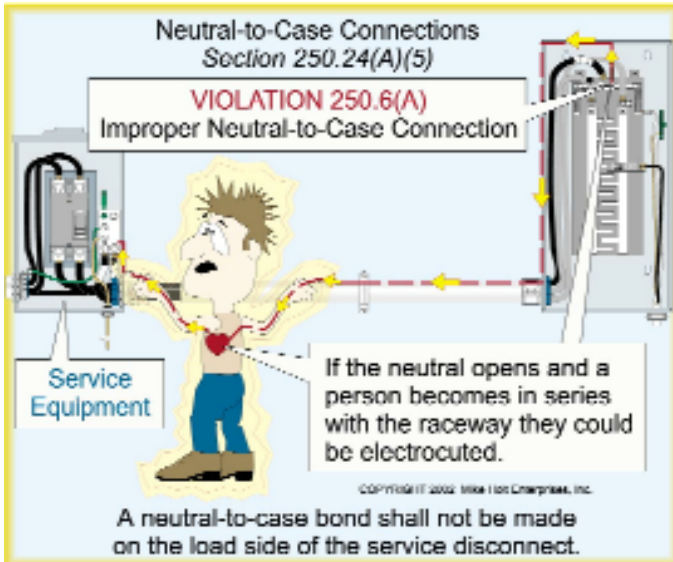

Figure 250-55

electric shock and even death from ventricular fibrillation can occur if a neutral-to-case connection is made. Figure 250-55

- (B) **Grounded (neutral) Conductor Brought to Each Service.** Because electric utilities are not required to install an equipment grounding (bonding) conductor, services supplied from a grounded utility transformer shall have a grounded (neutral) conductor run from the electric utility transformer

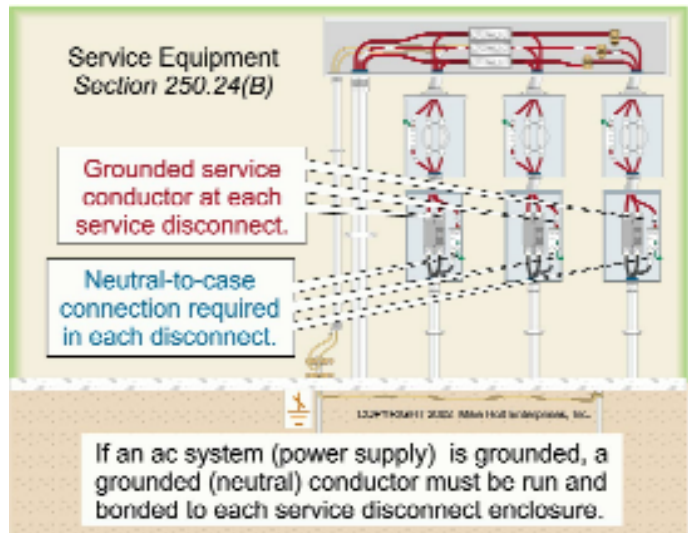

Figure 250-57

to each service disconnecting means. The grounded (neutral) conductor shall be bonded to the enclosure of each disconnecting means. Figures 250-56 and 250-57

**AUTHOR'S COMMENT:** It is critical that the metal parts of service equipment be bonded to the grounded (neutral) conductor (effective ground-fault current path) to ensure that dangerous voltage from a ground fault will be quickly removed [250.4(A)(3) and 250.4(A)(5)]. To accomplish this, the grounded (neutral) conductor shall be run to service equipment from the electric utility, even

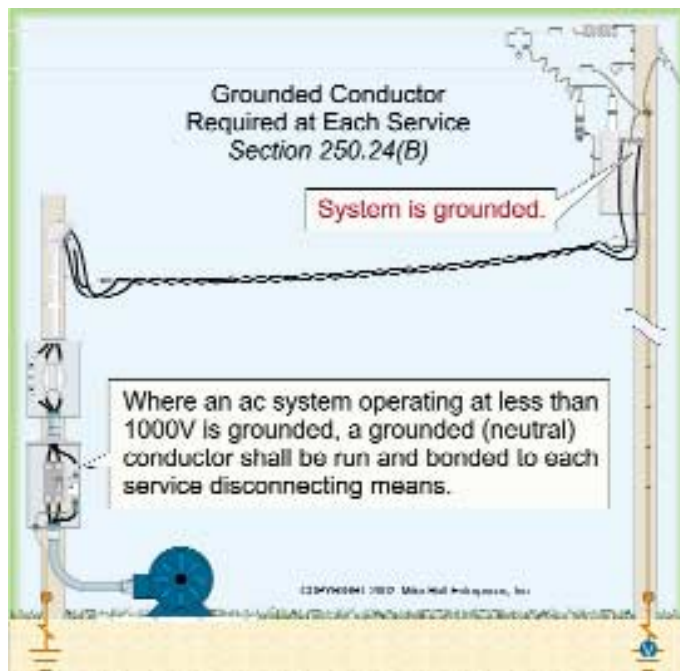

Figure 250-56

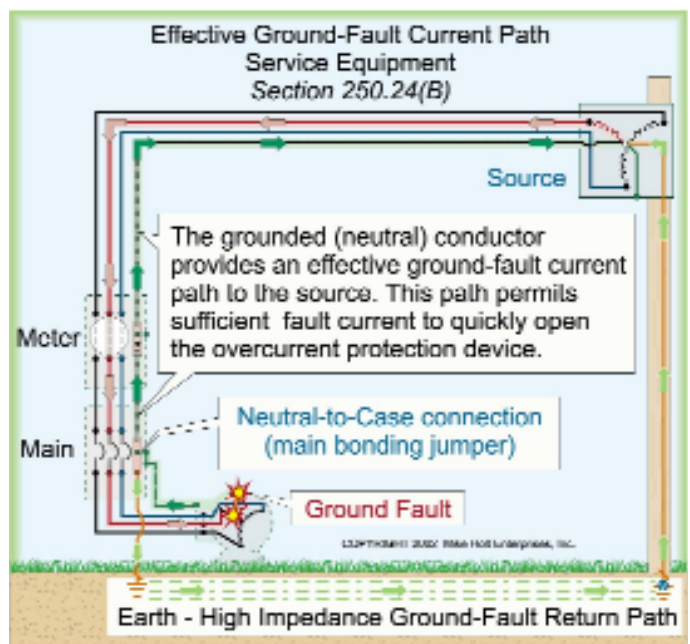

Figure 250-58

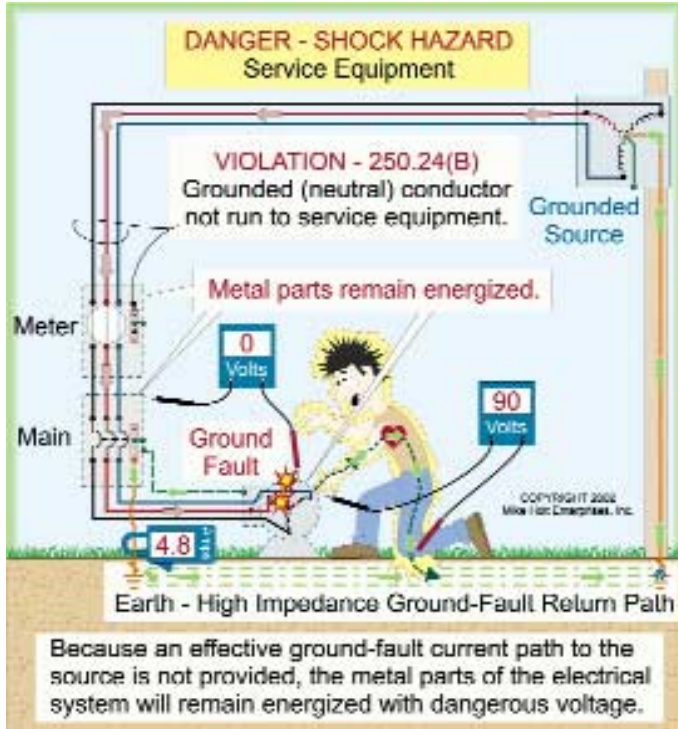

Figure 250-59

when there are no line-to-neutral loads being supplied!  
Figure 250-58

**DANGER:** If the grounded (neutral) service conductor is not run between the electric utility and service equipment, there would be no low-impedance effective ground-fault current path. In the event of a ground fault, the circuit protection device will not open and metal parts will remain energized. Figure 250-59

**(1) Minimum Size Grounded (neutral) Conductor.**

Because the grounded (neutral) service conductor is required to serve as the effective ground-fault current path, it shall be sized so that it can safely carry the maximum ground-fault current likely to be imposed on it [110.10 and 250.4(A)(5)]. This is accomplished by sizing the grounded (neutral) conductor in accordance with Table 250.66, based on the total area of the largest ungrounded conductor. In addition, the grounded (neutral) conductors shall have the capacity to carry the maximum unbalanced neutral current in accordance with 220.22. Figure 250-60

**Question:** What is the minimum size grounded (neutral) service conductor required for a 400A, 3-phase, 480V service where the ungrounded service conductors are 500 kcmil and the maximum unbalanced load is 100A? Figure 250-61

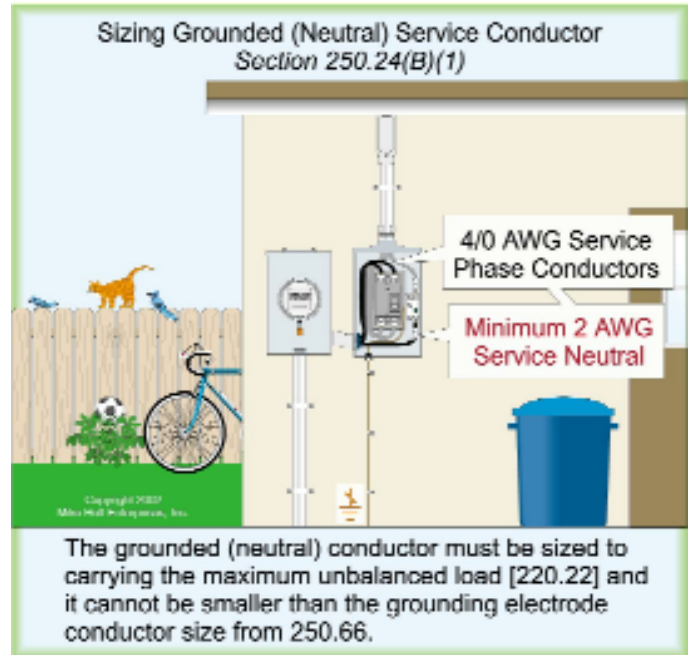

Figure 250-60

- (a) 3 AWG
- (b) 2 AWG
- (c) 1 AWG
- (d) 1/0 AWG

**Answer:** (d) 1/0 AWG

Table 250.66 = 1/0 AWG. The unbalanced load requires a 3 AWG rated for 100A in accordance with Table 310.16, but 1/0 AWG is required to accommodate the maximum possible fault current [310.4]. At the service, the grounded (neutral) conductor also serves as the effective ground-fault current path to the power source.

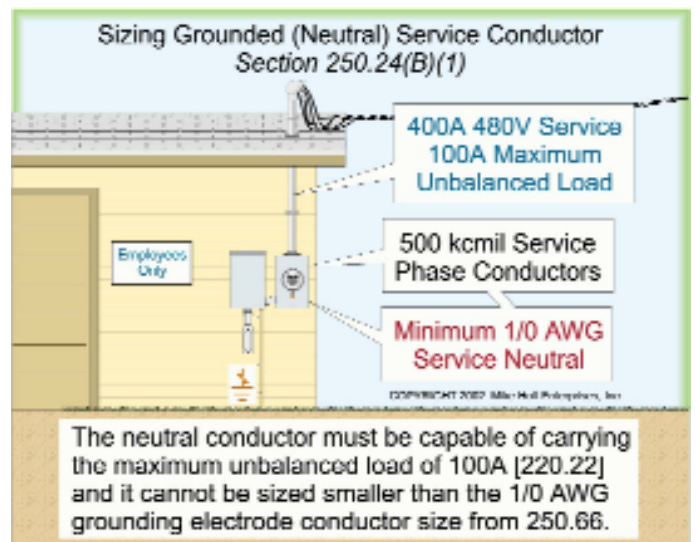

Figure 250-61

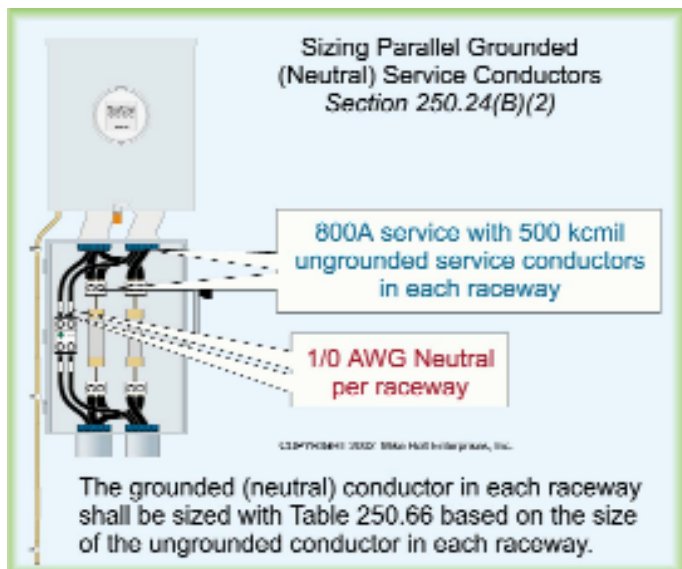

Figure 250-62

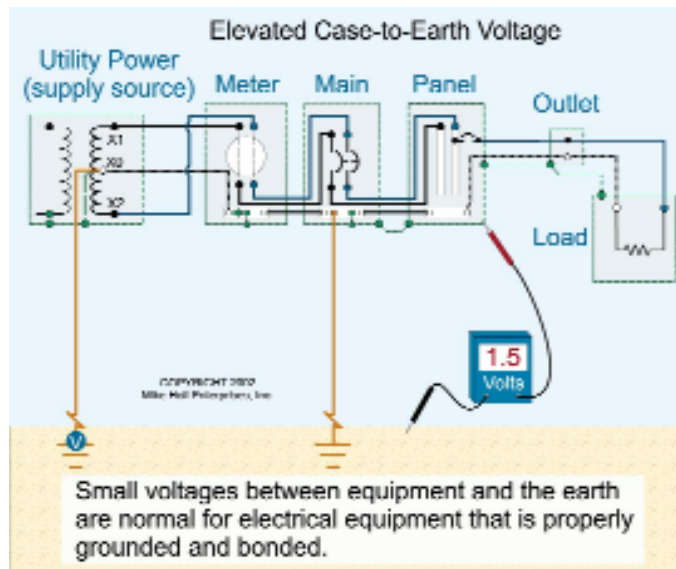

Figure 250-63



(2) **Parallel Grounded Conductor.** Where service conductors are installed in parallel, a grounded (neutral) conductor shall be installed in each raceway, and each grounded (neutral) conductor shall be sized in accordance with Table 250.66 based on the size of the largest ungrounded conductor in the raceway.

**Question:** What is the minimum size grounded (neutral) service conductor required for an 800A, 480V, 3Ø service installed in two raceways, if the maximum unbalanced neutral load is 100A? The ungrounded service conductors in each raceway are 500 kcmil. Figure 250-62

- (a) 3 AWG
- (b) 2 AWG
- (c) 1 AWG
- (d) 1/0 AWG

**Answer:** (d) 1/0 AWG per raceway, 310.4 and Table 250.66

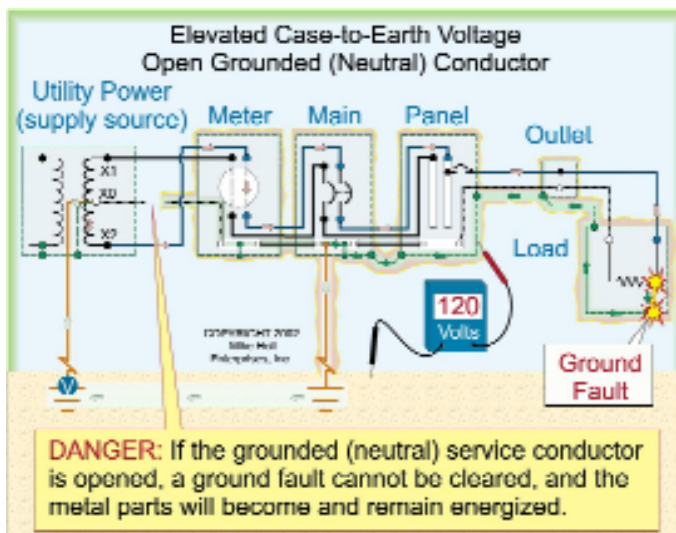

Figure 250-64

**Danger of Open Service Neutral**

The bonding of the grounded (neutral) conductor to the service disconnect enclosure creates a condition where ground faults can be quickly cleared and the elevated voltage on the metal parts will not be much more than a few volts. Figure 250-63

**Shock Hazard.** However, if the grounded (neutral) service conductor, which serves as the effective ground-fault current path, is opened, a ground fault cannot be cleared and the metal parts of electrical equipment, as well as metal piping and structural steel, will become and remain energized providing the potential for electric shock. Figure 250-64

When the service grounded (neutral) conductor is open, objectionable neutral current flows onto the metal parts of the electrical system because a neutral-to-case connection (main bonding jumper) is made at service equipment. Under this condition, dangerous voltage will be present on the metal parts providing the potential for electric shock as well as fires. This dangerous electrical shock condition is of particular concern in buildings with pools, spas and hot tubs. Figure 250-65



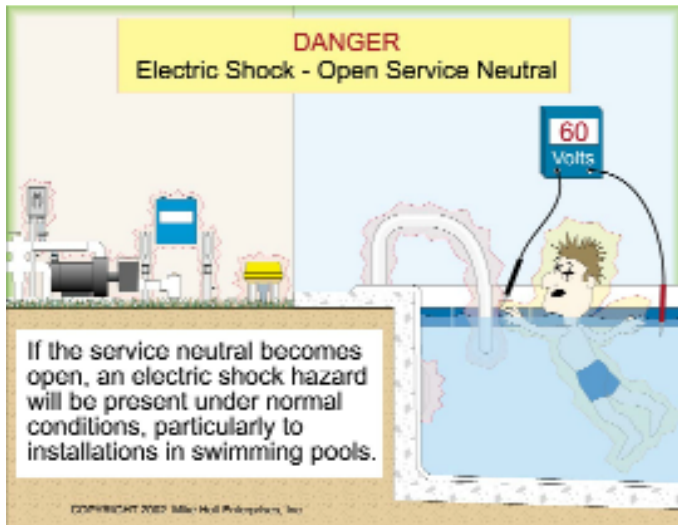

Figure 250-65

**AUTHOR'S COMMENT:** To determine the actual voltage on the metal parts from an open service grounded (neutral) conductor, you need to do some fancy math calculations with a spreadsheet to accommodate the variable conditions. Visit [www.NECcode.com](http://www.NECcode.com) and go to the Free Stuff link to download a spreadsheet for this purpose.

**Fire Hazard.** If the grounded (neutral) service conductor is open, neutral current flows onto the metal parts of the electrical

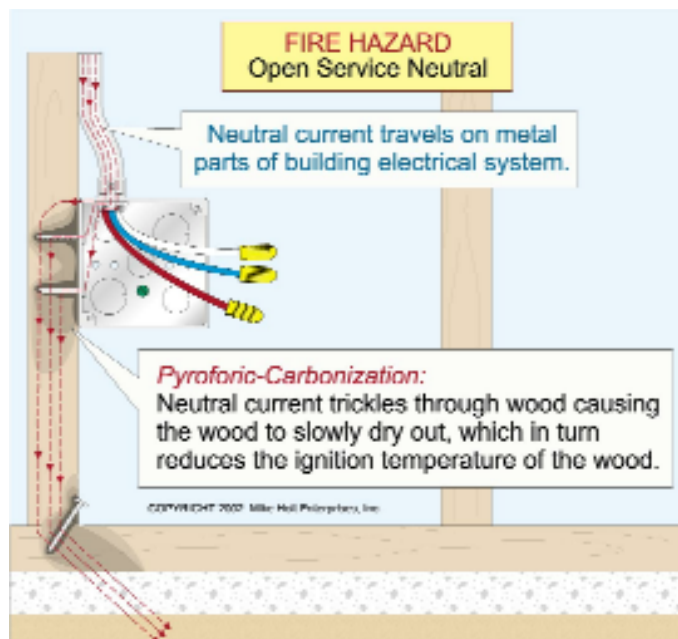

Figure 250-66

system. When this occurs in a wood frame construction building or structure, neutral current seeking a return path to the power supply travels into moist wood members. After many years of this current flow, the wood can be converted into charcoal (wood with no moisture) because of the neutral current flow, which can result in a fire. This condition is called pyroforic-carbonization. Figure 250-66

**AUTHOR'S COMMENT:** We can't create an acceptable graphic to demonstrate how pyroforic-carbonization causes a fire by an open service neutral. However, if you would like to order a video showing actual fires caused by pyroforic-carbonization, call 1-888-NEC-CODE.

### 250.28 Main Bonding Jumper

At service equipment, a main bonding jumper shall bond the metal service disconnect enclosure to the grounded (neutral) conductor. When equipment is listed for use as service equipment as required by 230.66, the main bonding jumper will be supplied by the equipment manufacturer [408.3(C)]. Figure 250-67

**AUTHOR'S COMMENT:** The main bonding jumper serves two very important needs. First, it establishes a connection between the equipment enclosure and the earth through the grounding electrode conductor to dissipate lightning and other high-voltage surges [250.4(A)(2)]. Secondly, it establishes a connection between the effective ground-fault current path and the service grounded (neutral) conductor to clear a ground fault. Figure 250-68

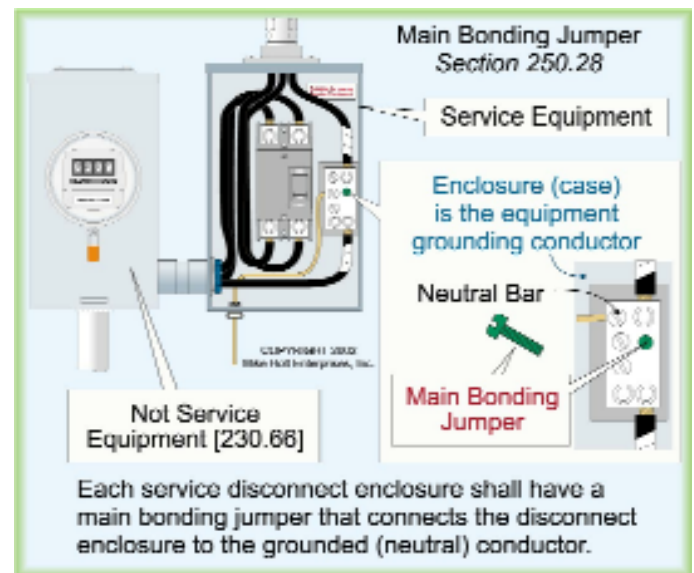

Figure 250-67

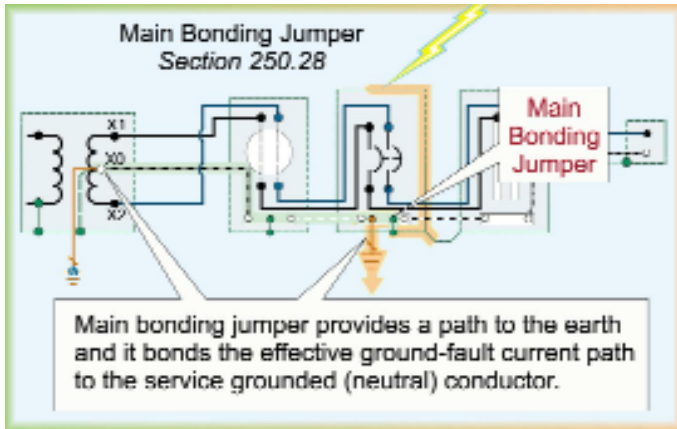

Figure 250-68

An effective ground-fault current path cannot be provided if a main bonding jumper is not installed in an installation where a CT enclosure is used. The result is that metal parts of the electrical installation will remain energized with dangerous voltage from a ground fault. Figure 250-69

- (A) **Material.** The main bonding jumper shall be a wire, bus, or screw of copper or other corrosion-resistant material.
- (B) **Construction.** Where a main bonding jumper is a screw, the screw shall be identified with a green finish that shall be visible with the screw installed.

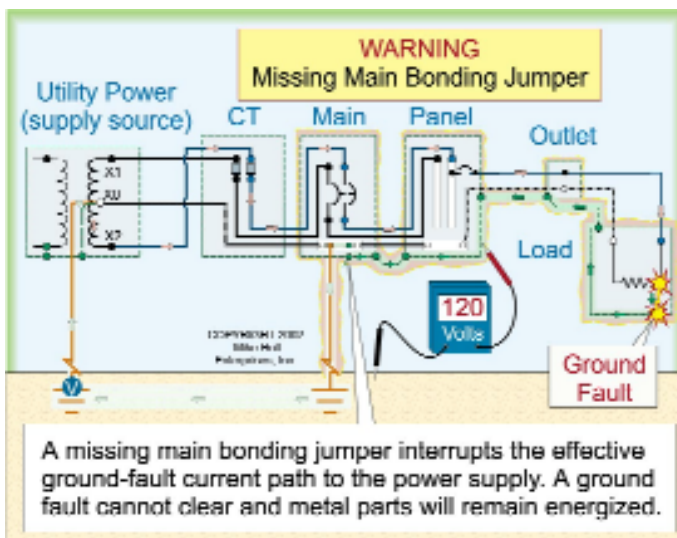

Figure 250-69

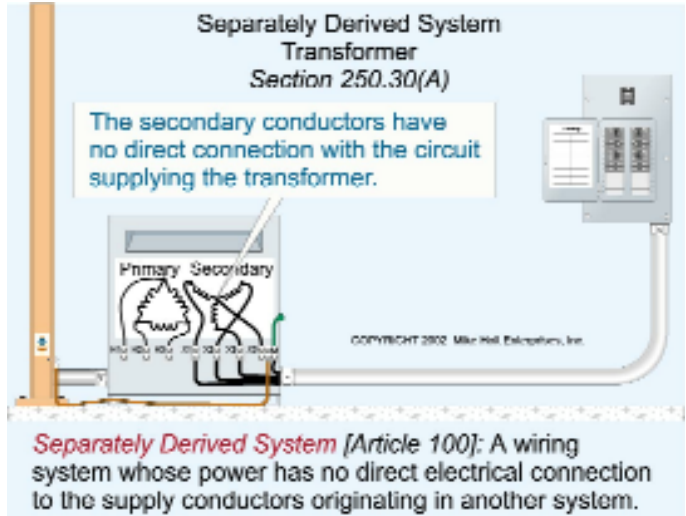

Figure 250-70

### 250.30 Grounding (and Bonding) Separately Derived Systems

**AUTHOR'S COMMENT:** A separately derived system is a premises wiring system that has no direct electrical connection to conductors originating from another system. See Article 100 definition and 250.20(D). All transformers, except an autotransformer, are separately derived because the primary supply conductors do not have any direct electrical connection to the secondary conductors. Figure 250-70

A generator, a converter winding or a solar photovoltaic system can only be a separately derived system if the grounded (neutral) conductor is opened in the transfer switch [250.20(D) FPN 1]. Figure 250-71

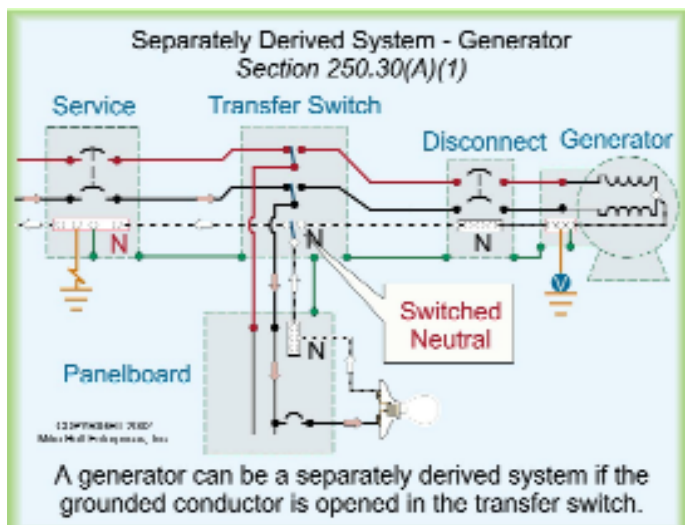

Figure 250-71

If a generator, which is not part of a separately derived system, is bonded in accordance with 250.30(A), dangerous objectionable neutral current will flow on the bonding paths in violation of 250.6(A). Figure 250-72

All online UPS systems are separately derived even if the input and output voltages are the same. An automatic transfer switch has no impact on this determination. This is because an isolation transformer is provided as part of the module. Utilize caution when connecting these systems.

- (A) **Grounded Systems.** Separately derived systems that operate at over 50V [250.20(A) and 250.112(I)] shall comply with the bonding and grounding requirements of 250.30(A)(1) through (A)(6).

**AUTHOR'S COMMENT:** Bonding the metal parts on the secondary of the separately derived system to the secondary grounded (neutral) terminal ensures that dangerous voltage from a ground fault on the secondary can be quickly removed by opening the secondary circuit's overcurrent protection device [250.2(A)(3)]. In addition, separately derived systems are grounded to stabilize the line-to-earth voltage during normal operation [250.4(A)(1)]. Figure 250-73

- (1) **Bonding Jumper (Neutral-to-Case Connection).** To provide the effective ground-fault current path necessary to clear a ground fault on the secondary side of the separately derived system, the metal parts of electrical equipment shall be bonded to the grounded (neutral) terminal of the separately derived system. The bonding

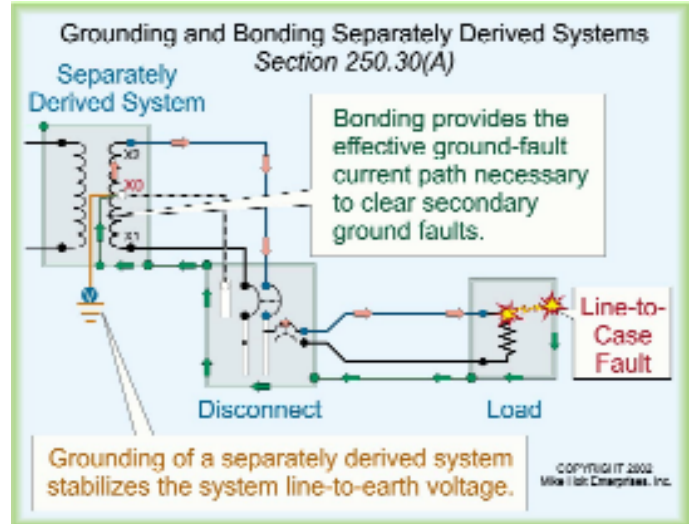

Figure 250-73

jumper used for this purpose shall be sized in accordance with Table 250.66 based on the area of the largest derived ungrounded conductor. Figure 250-74

**Question:** What size bonding jumper is required for a 45 kVA transformer if the secondary conductors are 3/0 AWG? Figure 250-75

- (a) 4 AWG
- (b) 3 AWG
- (c) 2 AWG
- (d) 1 AWG

**Answer:** (a) 4 AWG, Table 250.66

**DANGER:** If a bonding jumper is not installed from the equipment grounding (bonding) conductor to the

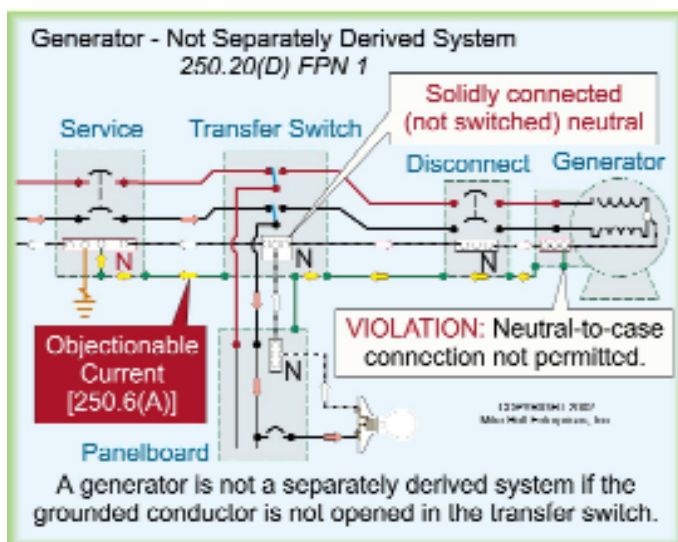

Figure 250-72

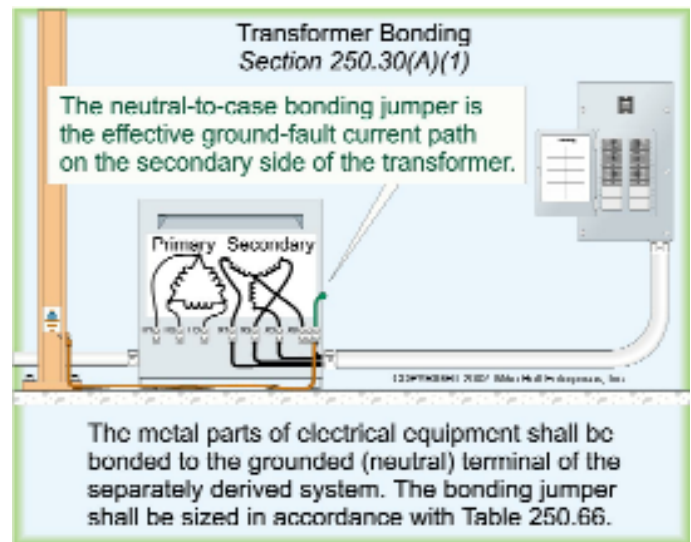

Figure 250-74

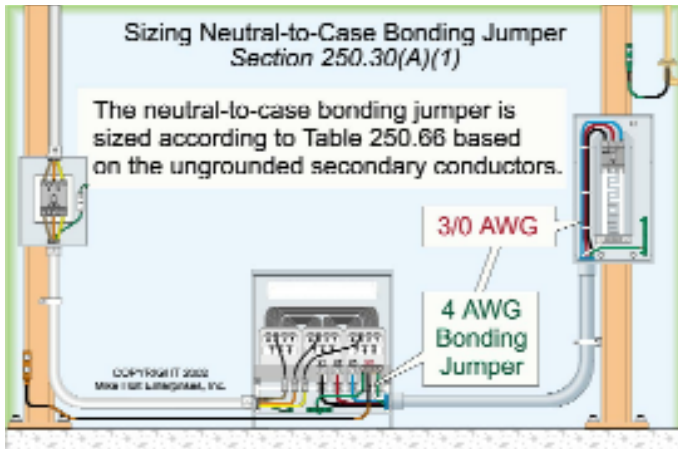

Figure 250-75

*grounded (neutral) terminal of the separately derived system, then a ground fault cannot be cleared and the metal parts of electrical equipment, as well as metal piping and structural steel, will remain energized providing the potential for electric shock as well as fires. Figure 250-76*

**AUTHOR'S COMMENT:** The neutral-to-case bonding jumper establishes the effective ground-fault current path for the equipment grounding (bonding) conductor on the secondary and the separately derived system (secondary). To protect against a primary ground fault, the primary circuit conductors shall contain an effective ground-fault current path. Figure 250-77

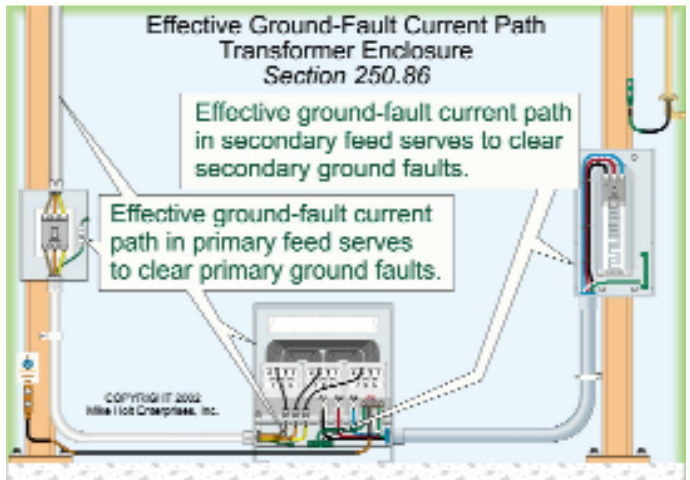

Figure 250-77

The point of connection for the separately derived system neutral-to-case bond shall be made at the same location where the separately derived grounding electrode conductor terminates in accordance with 250.30(A)(2)(a). Figure 250-78

The neutral-to-case bond can be made at the source of a separately derived system or at the first system disconnecting means, but not at both locations. Figure 250-79

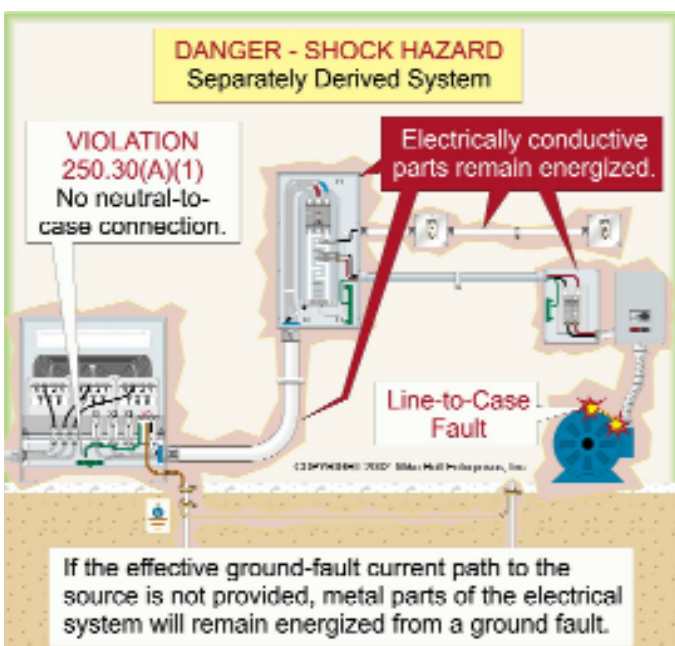

Figure 250-76

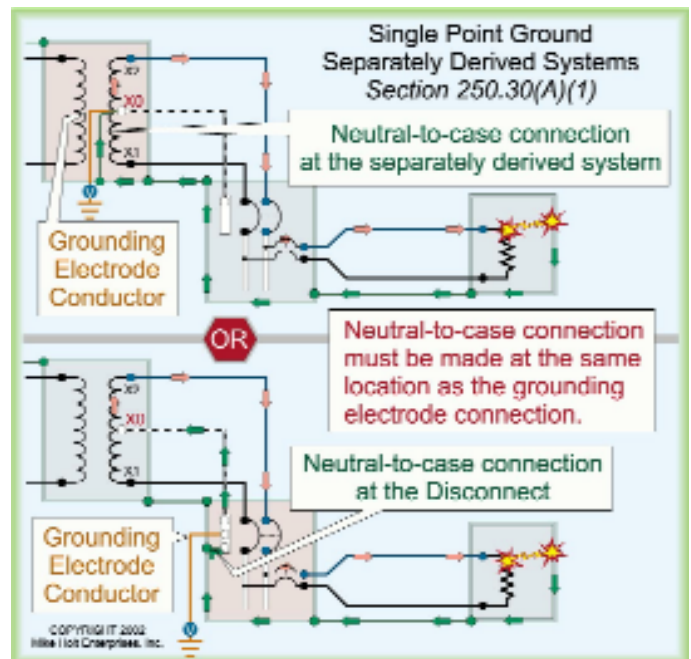

Figure 250-78

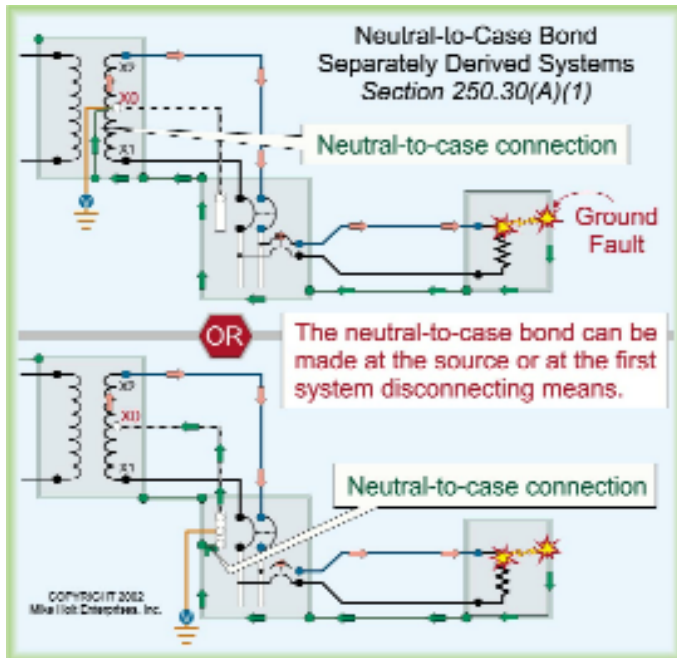

Figure 250-79

**CAUTION:** The neutral-to-case bond for a separately derived system cannot be made at more than one location, because doing so results in a parallel path(s) for neutral current. Multiple neutral current return paths to the grounded (neutral) terminal of the power supply can create dangerous objectionable current flow on grounding and bonding paths in violation of 250.6 and 250.142(A). Figure 250-80

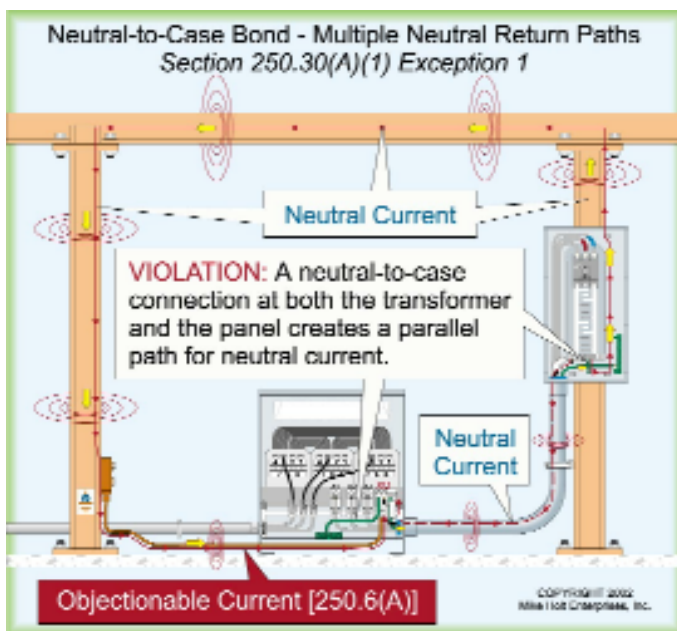

Figure 250-80

**Exception No. 2:** The bonding jumper for a system rated not more than 1,000 VA shall not be smaller than the derived phase conductors, and shall not be smaller than 14 AWG copper.

- (2) **Grounding.** To stabilize the line-to-earth voltage during normal operation, a grounding electrode conductor shall ground the separately derived system grounded (neutral) conductor to a suitable grounding electrode.
  - (a) **Single Separately Derived System.** The grounding electrode conductor for a single separately derived system shall be sized in accordance with 250.66, based on the area of the largest separately derived ungrounded conductor. This conductor shall ground the grounded (neutral) conductor of the separately derived system to a suitable grounding electrode as specified in 250.30(A)(4). Figure 250-81

**AUTHOR'S COMMENT:** The grounding electrode conductor connection shall terminate directly to the grounded (neutral) terminal, not to the separately derived system enclosure.

To prevent objectionable current from flowing on grounding and bonding conductors, the grounding electrode conductor shall terminate at the same point on the separately derived system where the

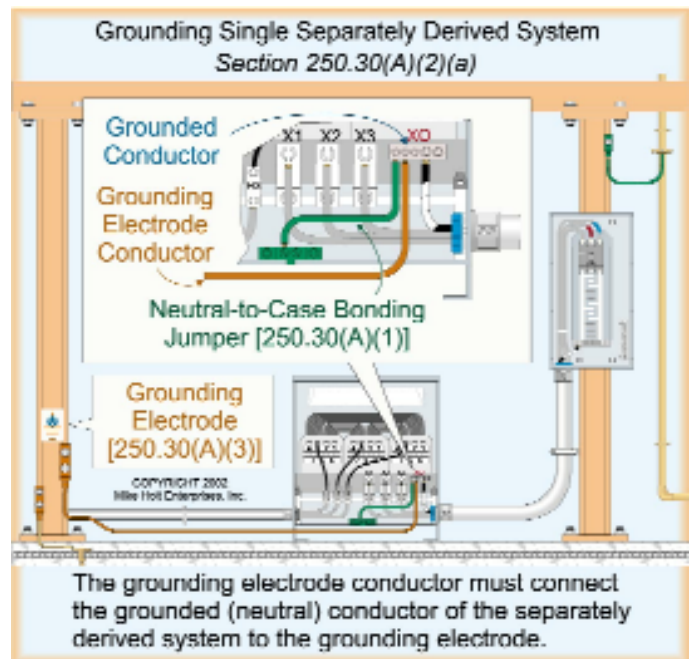

Figure 250-81

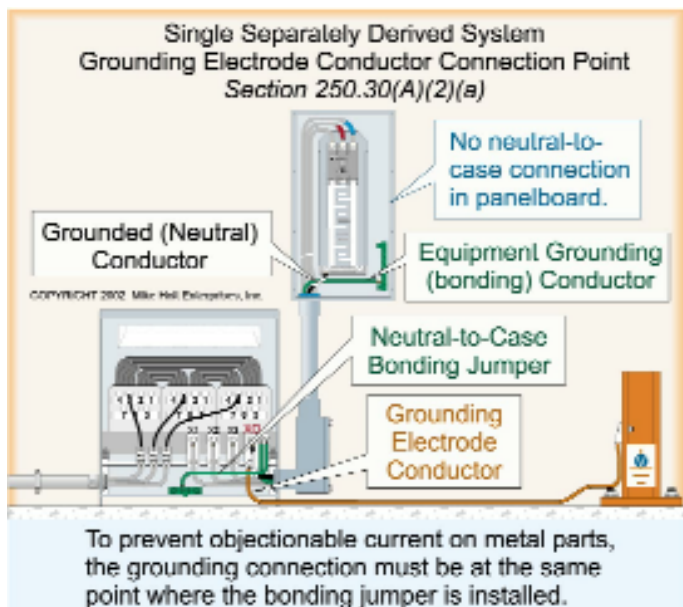

Figure 250-82

neutral-to-case bonding jumper is installed. Figure 250-82

**Exception:** A grounding electrode conductor is not required for a system rated not more than 1,000 VA. However, the system shall be bonded in accordance with 250.30(A)(1) Ex. 2.

(b) Multiple Separately Derived Systems. Where multiple separately derived systems are grounded to a common grounding electrode conductor as provided in 250.30(A)(3), the common grounding electrode conductor shall be sized in accordance with Table 250.66 based on the total circular mil area of the separately derived ungrounded conductors from all of the separately derived systems. Figure 250-83

(3) **Grounding Electrode Taps.** A grounding electrode tap from a separately derived system to a common grounding electrode conductor shall be permitted to ground the grounded (neutral) terminal of the separately derived system to a common grounding electrode conductor.

(a) Tap Conductor Size. Each grounding electrode tap conductor shall be sized in accordance with 250.66, based on the size of the largest separately derived ungrounded conductor of the separately derived system.

(b) Connections. All grounding electrode tap connections shall be made at an accessible location by a listed irreversible compression connector, listed

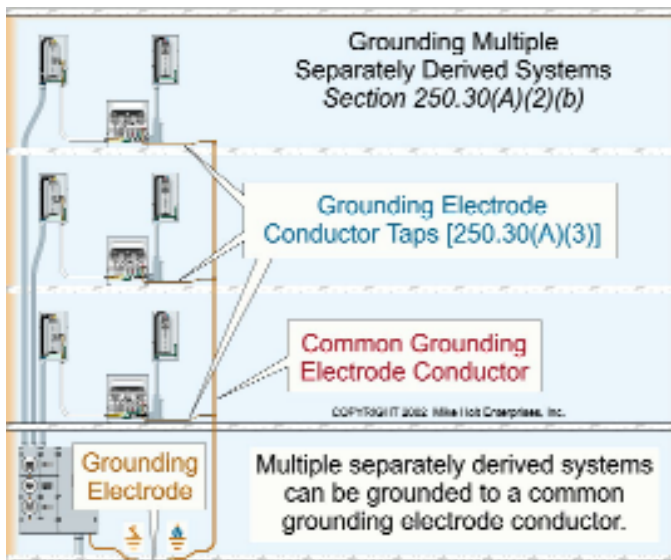

Figure 250-83

connections to copper busbars, or by exothermic welding. Grounding electrode tap conductors shall be grounded to the common grounding electrode conductor as specified in 250.30(A)(2)(b) in such a manner that the common grounding electrode conductor is not spliced.

(c) Installation. The common grounding electrode conductor and the grounding electrode taps to each separately derived system shall be:

- Copper where within 18 in. of earth [250.64(A)].
- Securely fastened to the surface on which it is carried and adequately protected if exposed to physical damage [250.64(B)].
- Installed in one continuous length without a splice or joint, unless spliced by irreversible compression-type connectors listed for the purpose or by the exothermic welding process [250.64(C)].
- Metal enclosures (such as a raceway) enclosing a common grounding electrode conductor shall be made electrically continuous from the point of attachment to cabinets or equipment to the grounding electrode and shall be securely fastened to the ground clamp or fitting [250.64(E)].

(4) **Grounding Electrode Conductor.** The grounding electrode conductor shall terminate to a suitable grounding electrode that is located as close as practicable and preferably in the same area as the grounding electrode conductor termination to the grounded (neutral) conductor. The grounding electrode shall be the nearest one of the following:

- (1) Effectively grounded metal member of the structure.
- (2) Effectively grounded metal water pipe, within 5 ft from the point of entrance into the building.

**Exception:** For industrial and commercial buildings where conditions of maintenance and supervision ensure that only qualified persons service the installation, the grounding electrode conductor can terminate on the metal water-pipe system at any point, if the entire length of the interior metal water pipe that is being used for the grounding electrode is exposed.

(3) Where none of the grounding electrodes as listed in (1) or (2) above are available, one of the following grounding electrodes shall be used:

- A concrete-encased grounding electrode encased by at least 2 in. of concrete, located within and near the bottom of a concrete foundation or footing that is in direct contact with earth, consisting of at least 20 ft of one or more bare or zinc galvanized or other electrically conductive coated steel reinforcing bars or rods of not less than 1/2 in. in diameter, or consisting of at least 20 ft of bare copper conductor not smaller than 4 AWG [250.52(A)(3)].
- A ground ring encircling the building or structure, buried at least 30 in., consisting of at least 20 ft of bare copper conductor not smaller than 2 AWG [250.52(A)(4) and 250.53(F)].
- A ground rod having not less than 8 ft of contact with the soil [250.52(A)(5) and 250.53(G)].
- A buried ground plate electrode with not less than 2 sq ft of exposed surface area [250.52(A)(6)].
- Other metal underground systems or structures, such as piping systems and underground tanks [250.52(A)(7)].

FPN: Interior metal water piping in the area served by a separately derived system shall be bonded to the grounded (neutral) conductor at the separately derived system in accordance with the requirements contained in 250.104(A)(4).

(5) **Equipment Bonding Jumper Size.** Where an equipment bonding jumper is run with the derived phase conductors from the source of a separately derived system to the first disconnecting means, it shall be sized in accordance with Table 250.66, based on the total area of the largest separately derived ungrounded conductors.

(6) **Grounded (neutral) Conductor.** Where the neutral-to-case bond is made at the first system disconnecting means, instead of at the source of the separately derived system, the following requirements shall apply: Figure 250-84

- (a) **Routing and Sizing.** Because the grounded (neutral) conductor is to serve as the effective ground-fault current path, the grounded (neutral) conductor shall be routed with the secondary conductors, and it shall be sized no smaller than specified in Table 250.66, based on the largest derived ungrounded conductor.
- (b) **Parallel Conductors.** If the secondary conductors are installed in parallel, the grounded (neutral) secondary conductor in each raceway shall be sized based on the area of the largest derived ungrounded conductors in the raceway.

**AUTHOR'S COMMENT:** When the neutral-to-case bonding jumper is located in the first system disconnecting means, the grounding electrode conductor shall terminate at the same location to prevent objectionable current from flowing on grounding and bonding paths [250.30(A)(2)(a)].

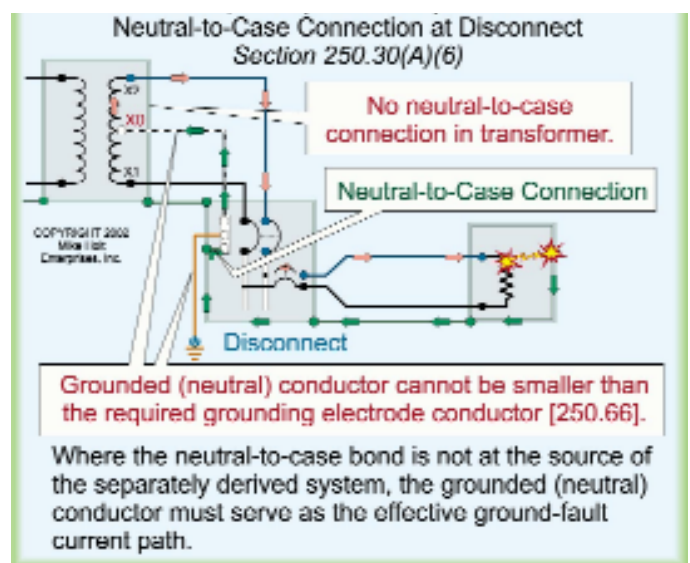

Figure 250-84





# Index

Part	Description	Page
1	A Bit of Philosophy	1
2	What is Electricity?	1
3	Magnetism	2
4	Sources of Electric Energy	2
5	Analogies	3
6	Definitions	3
7	Modifying an Equation	4
8	Conductors and Insulators	4
9	Power	5
10	Alternating Current	6
11	Transformers	7
12	More Definitions	8
13	Electromagnetism	9
14	Transformation Ratio	10
15	Power Factor	10
16	Vectors	11
17	Voltage Drop	12
18	Cores	13
19	Butt, Wound, and Mitered Cores	13
20	Wound Cores	14
21	Mitered Cores	14
22	Coils	15
23	Insulating Transformers	15
24	Short Circuit Stresses	15
25	Taps	16
26	Wiring Diagrams	16
27	Convenience of Tap Connections	17
28	Three Phase Power	17
29	Buck and Boost Transformers	19
30	Easy Selector Chart	19
31	How Buck and Boost Are Used	21
32	Improper Connections	21
33	Insulation Life and Temperature	22
34	Average Conductor Rise Vs. Hot Spot	23
35	Average Conductor Rise	23
36	Ambient to Ultimate Temperature	23
37	Insulation "Half Life"	24
38	20,000 Hours	24
39	Extending Life	25
40	Auto Transformers for 208Y/120 Volt Service	25
41	Co-Ratio	28
42	Tee-Connected Transformers	29
43	Three Phase Core-Type Transformers Connections	31
44	Full Load Current Charts and Sound Levels	32

## Part I

### A Bit of Philosophy

The greatest barrier to the development of personal skills is lack of motivation. When something, or someone, turns on your ignition key of desire to achieve an obtainable goal, you have taken the first giant step forward in building personal know-how, self-confidence, and growth in whatever field you choose.

At this point you probably wonder why we, at Square D, should even begin to philosophize about your success and your personal development. So let's lay all the cards on the table and level with each other.

We are in the business of making quality products to better serve the electrical industry. Those products, even if they were the most functional, efficient, and useful, will gather dust in our factories and warehouses until someone, somewhere, realizes they can bring a benefit to a potential user, resulting in an earned commission to a salesman, and hence continued growth to our company. So in a nutshell the key to our success is very simply people like "you"!

It is human nature to be fearful of something we do not completely understand. This, in itself, can be a serious obstacle to an otherwise successful selling career! To remove that fear, simply eliminate the mystery by participating in a well organized learning process. For example, assume you were selling for an organization that repaired and overhauled motors and you were suddenly informed that your top management decided to add the Square D line of transformers to its family of saleable products. Instinctively a number of negative thoughts could enter your mind such as:

"But I don't know anything about transformers," or,

"What customers really use these products?"

Possibly dozens of other negative thoughts flash through your mind until finally the practical side of the "big picture" comes into focus. You suddenly realize that a new opportunity awaits you, that your earning power can be enhanced, and that the very customers who use motors, also need dry-type transformers. In a sense you are better off than the new man with an electrical background who joins an existing organization, for you already have established a good reputation and sales rapport with your customers. All you really have to do is learn the language of an exciting new product line. This is where Square D can come to your rescue by providing a simple series of bulletins, brochures or ABC's, if you prefer to think of them that way, that can make you comfortable when face to face with customers.

The information which follows will be developed on the assumption you know nothing about basic electricity or our products. Should you be farther along than this assumption presumes, we hope you will bear with us during the beginning sections for the benefit of those less fortunate than you!

## Part II

### What Is Electricity?

Man's first observation of electricity was in nature's display of lightning which can be beautiful from a safe distance and awe inspiring, if not terrifying, when its action is close at hand. One of the most beautiful sights that can be observed by a passenger in a jet plane flying about a violent thunderstorm at night, is the spectacular display of inter-cloud lightning. The brilliant, jagged, instantaneous flashes are nature's way of equalizing the voltage between adjacent clouds at a speed of 186,000 miles per second. We can contrast this to a lazy river that permits water at a high elevation to flow at a few miles an hour to find its leisurely way to the oceans. In a sense electricity also wants to seek its level, and therein becomes a useful servant of man. We can harness the energy of water stored in high level lakes or rivers by building huge dams to control its flow for purposes of creating navigable waterways, irrigation systems, or to drive waterwheels for mechanical power which, in turn, rotates factory drive shafts, grist mills, or even the powerful hydraulic turbines which become the prime movers of giant electric generators.

Do not be disappointed or concerned that you may not understand all the ramifications of the electron theory. Even the best trained electrical engineers have never seen an electron or an ampere flow in a wire but merely the physical manifestation of what this "current" does in its movement from one voltage level to another. In a lightning bolt we do not see the electron flow, only the white hot heat created as it passes from one cloud to another, or to earth. In a toaster or a heating element we do not see the current flow but only the red glow that toasts our bread or keeps us warm. In a motor, never the electron, but only the rotating force it creates as it surges through the windings. Thus most of man's technical effort has been devoted to controlling this powerful servant to provide a multitude of functions useful to all of humanity.

Even the tremendous power of lightning has been controlled to a significant degree by man's genius so that it does not destroy our power lines or the apparatus and equipment attached thereto. This development will be a later subject to be discussed after we learn more of the fundamentals!

## Part III

### Magnetism

The Creator in all His wisdom, made our earth a great magnet. In so doing, seagoing navigators ages ago learned how to utilize this phenomenon to accurately sail their ships from one port to another.

All of us are aware that the earth spins on an axis, the opposite ends of which have been designated as the geographic north and south poles. The earth has two other poles which are known as magnetic poles. The one near the north geographic pole is called the north magnetic pole, and the opposite one, the south magnetic pole. Invisible lines of force defined as magnetic lines of force, completely surround the earth. Oversimplified, but adequate for our purpose, these invisible lines enter at one pole, pass through the earth, exit at the other pole and complete their path external to the earth. They exist close to the earth and miles above the earth, hence become useful to the mariner on the high seas, the hunter in the woods and the airplane pilot.

Ancient mariners learned that certain substances found on earth, and known as lodestones, possessed the unusual characteristics if suspended on a string, a thread, or a pivot, that in most places on the surface of the world would always point approximately north and south. If the lodestone was deliberately moved from this position it would slowly return to its original line of position. This gave evidence to the existence of a strange force which could be utilized by man. Over many centuries curious minds became enamored with this phenomenon. The cumulative impact of all these studies and observations gradually evolved into the great electrical industry, without which our world of comfort could never be what it is.

Lodestones were not of convenient shape; hence, through the years inventive individuals were able to fashion magnetic pointers which ultimately became the compass needle so commonplace today.

Long after the mariner's compass became a universally useful navigational instrument, other pioneering scientists observed that if a piece of wire was caused to cut across these magnetic lines of force, a voltage could be measured between the ends of the wire. They also learned that if ends were touched together something else happened. A tiny spark could be seen if the wire was long enough and was moved very rapidly. Gradually as these phenomena were experienced by pioneer scientists and the word of their observations were circulated to similarly interested men, the pieces began to fall into place.

While they did not understand the causes, they gradually developed the idea that something was flowing in the wire. In due course new words such as voltage, current, resistance, insulation, and many others began to creep into the strange new jargon of scientific vocabulary. Each new discovery either supported or denied a previous concept or understanding, and through such evolution, order developed out of conflicting opinions. Today, the industry has a very precise understanding of the true conditions involving electricity and magnetism. The names of many of these determined pioneers will live forever in history as units of measurement, products they created, or companies they formed, bear their family names in recognition of their achievement and contribution to better living through electrical energy.

In the sections that follow this introductory presentation, we will strive to keep our explanations easy to read, as simple as possible, and as accurate as need be to accomplish our purpose of fundamental understanding.

## Part IV

### Sources of Electric Energy

Our initial presentation essentially sets the stage for that which follows. We wrote of lightning as a source of tremendous energy. We know it can strip the bark from trees, split a giant trunk in an instant of time, and set forests afire. How this tremendous energy is created in the heavens is a very interesting process of friction between rapidly rising air currents within existing air masses, but from the point of view of these writings it has little direct bearing on the subject at hand. For relaxing and exciting reading the libraries are replete with weather books that explain gentle warm fronts, violent cold front movements that create the massive thunderheads, and the terrifying hurricanes that originate in the doldrums to the north of the equator. While lightning is mostly a summer phenomenon, humans can create their own little "lightning" discharges in the winter time when the atmosphere is dry. As one walks across a carpet, a harmless unexpected shock is experienced when a doorknob, a light switch or a metal object is touched with the bare hand. Yet, like lightning, static electricity is only of passing interest to the readers of these articles.

Another source of electric energy is chemical in nature. Primary or secondary cells as used in flashlights or

automobile batteries, provide limited blocks of power and have the disadvantage of exhausting their usefulness or requiring periodic recharge. We will not go into the chemistry of these products but will use direct current principles as a foundation to better understanding of the final step involving alternating current apparatus.

## Part V Analogies

It is indeed fortunate that hydraulic systems relate closely to electrical phenomena. By comparing something we understand in every day life, it is easier to grasp a similar concept with which we are less experienced. The water systems in our homes present an almost perfect parallel set of conditions.

Let us assume that the water pressure at the point of supply is maintained as a constant 50 pounds per square inch. A faucet fully closed prevents any water flow, partially open releases a trickle, and wide open allows maximum flow.

You have undoubtedly observed when sprinkling your lawn that more gallons of water flow from the end of the garden hose if you use only one fifty foot length, than if you had coupled another section in series with it. Even though the water pressure is maintained constant at the sprinkler faucet, we deliver fewer gallons of water with the longer hose because of the added internal friction or resistance. We would also deliver less water if we used a 1/2" diameter hose rather than a 5/8" or a 3/4" hose because the internal resistance is higher in the smaller unit!

We can now relate these observations to an electrical circuit. The electrical voltage in our homes is similar to water pressure. Amperes, or current, in an electrical circuit relates to the gallons of water flowing from the end of the hose. Electrical resistance is similar to hose resistance, and becomes greater as the wire length is increased or its size is decreased.

With these simple concepts it is easy to understand why a 25 watt lamp bulb requires less power to operate than a 100 watt lamp. The thin filament in the small 25 watt unit has four times the resistance of the larger lamp. Therefore, it permits only 1/4 the amount of current, or amperes, to flow. The power bill is proportionately smaller because you have used fewer watts. If you were to turn on two 100 watt lamps in the living room you would use twice the amount of current just as using two garden hoses from two different sprinkler faucets would allow twice the gallons of water to flow if we assumed our house pressure remained constant.

## Part VI Definitions

We have already mentioned the terms current and amperes as being closely related. Just as gallons is a unit of measure related to liquid mass, amperes is a unit that gives meaning and visualization of the amount of the electric current that flows in a metallic circuit.

Because voltage and resistance are related to current flow, a unit of measurement is also required for these. Most readers know that the unit to measure voltage or pressure in an electrical system is the "volt." Less well understood by non-technical people is the term "ohm" which expresses how much resistance is in a circuit. All three of these units are named in honor of the pioneers who many years ago experimented with and discovered the characteristics of these essential units.

Just as more pressure in a water system increases the gallons delivered, so in electricity the higher the pressure or voltage applied, the greater will be the flow of amperes. If we keep voltage constant and increase the resistance of the conducting wire or the appliance being used, then the current will be reduced. Fortunately, a very simple relationship exists that can be written as an equation and is known as "Ohm's" law. Let's call it equation #1.

$$I = \frac{E}{R}$$

Unfortunately, persons who have had little need to work with mathematics throw up their hands in fear when they see the word "equation." There truly is no mystery to it. The word is more ominous than what it means! It simply says what is on the left is equal to what is on the right. We also should identify the letters in the equation. "I" is by definition the letter chosen to represent "amperes" of current. Similarly "E" represents voltage and "R" stands for "ohms" of resistance.

Let us assume we want to know how many amperes flow in a circuit where the pressure is 12 volts and the resistance is 2 ohms. Merely substitute the values and the answer is obvious  $I = \frac{12}{2}$ , therefore, 6 amperes would flow in such a circuit.

This would be typical of a direct current system as used in your automobile where the power comes from a storage battery. If you turned on your parking lights and the ammeter which measures amperes pointed to 2, you could amaze your less experienced friends by telling them that obviously the combined resistance of all the lamps is exactly 6 ohms.

In our homes which are supplied at 120 volts the equation is still valid. If we had an electric heater whose elements had a resistance of 10 ohms, it would draw a current of  $I = \frac{120}{10}$  or 12 amperes. Later on, as easy as falling off a log, you will also know that it was a 1440 watt heater. However, for the present, let's stay a bit longer with Ohm's law.

## Part VII

### Modifying An Equation

We can tell you that  $I = \frac{E}{R}$  can also be written two different ways; namely,  $IR = E$  and  $R = \frac{E}{I}$ . Let us call these respectively equations 1, 2 and 3. If a beginner tries to remember all three of these his memory might trick him. Therefore we will show an easy way to derive these from the first one we mentioned, which you should try to remember! Just repeat  $I = \frac{E}{R}$  a dozen times today and it will spring out of your memory in the future just like magic. Do it now! I equals E over R!

The writer likes to treat an equation as if it were the "Golden Rule," – "To do unto others as you would have them do unto you," Because each side of the equal sign are equals, we must keep them that way. Whatever we do to one side, we must do likewise to the other, in order to keep them equal. For example: if we multiply each side of  $I = \frac{E}{R}$  by R, we then must get  $IR = \frac{ER}{R}$ . Any number divided by itself is 1 and since R is a particular number, then  $\frac{R}{R}$  also equals 1. Therefore the R's on the right side cancel out to 1 giving us a final result that  $IR = E$ .

If we take this equation #2 and divide each side by I, then the I's cancel out on the left side leaving us  $R = \frac{E}{I}$  which we previously called equation #3. That wasn't too tough, was it?

In summation, equation (1)  $I = \frac{E}{R}$  always tells us that the current will increase in exact proportion to the increase in voltage and that also it will decrease in the same proportion as R increases.

Equation (2)  $IR = E$  tells us that voltage is always equal to the product of R and I, so as either one increases, the voltage will also increase. Obviously, if either decreases, E will also decrease. Equation (3)  $R = \frac{E}{I}$  indicates that the resistance of a circuit is always equal to the voltage applied to it, divided by the current in the circuit. If we had a simple resistor as part of a circuit, its ohmic value can be determined by placing the terminals of a voltmeter on each side of the resistor, reading the value in volts and dividing that amount by the measured ammeter current flowing through the resistor. In later lessons we will learn a few more variables that exist in alternating current circuits that will modify these simple equations somewhat.

## Part VIII

### Conductors And Insulators

Technically, only a perfect vacuum is a perfect insulator. Many materials such as silver, copper, gold and aluminum are excellent conductors of electricity whereas air, certain gases, varnish, paper, rubber, mica, porcelain, glass, etc. are very poor conductors and hence are called insulators. The basic difference between these two broad classifications is that in conductors the structure of the atom is such that the electrons are relatively free to leave the nucleus of which they are a part. In an insulator they are tightly held to the nucleus. Because electric current is the actual movement of electrons from one atom to the next, those materials that have loosely bonded electrons are the best conductors.

It is fortunate that nature offers both types of materials for one can conduct electricity while the other prevents short circuits between conductors and minimizes leakage currents. The common lamp cord used in homes has relatively inexpensive rubber molded around the copper wire to confine the electron flow where we want it and to protect humans from electrical shock. The higher the voltage applied to the conductor, the thicker the insulation must be to minimize or reduce leakage and shock hazard.

The wire from our car battery to the starter motor is of relatively large diameter copper in order to carry the several hundred amperes necessary to turn over the engine. If we need large volumes of water we could use a fire hose, but to sprinkle our lawn a garden hose is quite adequate. The principle is the same, lower the resistance by increasing the diameter when we want large quantities of water or current.

The insulation on a 12 volt automobile system could be very thin, in the order of a few thousandths of an inch, but usually is covered with an added cloth braid to protect the rubber from being chafed or cut. In the country side where one observes very high voltage transmission lines from 69,000 to over 700,000 volts, no insulation is applied to the very heavy conductors. Because air is an insulator and space is not a serious problem up on the top of the towers, the added cost of insulation is saved and the conductors are widely separated. Of course at each tower, long strings of porcelain insulators support the conductor to prevent the electrons from escaping to ground through the tower, or to the adjacent conductor. Each of these insulators can withstand approximately 10,000 volts, and by counting the insulators in each string, a reasonable estimate of the applied voltage can be made.

In electrical equipment, however, space is at a premium, consequently carefully selected insulation becomes an important part of the product cost.

## Part IX

### Power

Now that we had a breather from equations, let's go one step farther and discuss power. In our water system we spoke of a faucet fully closed, partially open, or wide open to control the flow of water. In ordinary electric circuits we either wish to deliver full available power, or to shut it off completely. The ignition switch in your car, or the wall switch in your home performs exactly these functions. When we wish work to be done we close a switch connecting the source to the load. When the job is finished we open the switch and insert an air gap in the circuit to prevent the flow of current. It's that simple. When we must control large blocks of power at higher voltages, the simple switch grows in cost, size and complexity and is known as a power circuit breaker.

Power is expressed in watts, kilowatts or megawatts. A kilowatt is 1000 watts, whereas a megawatt is a million watts. The first two units are commonplace in our homes but the third is an expression used mainly in bulk power.

The "watt" was named after James Watt, an early pioneer in the electrical field. It represents the work done in one second, by one volt of potential moving one ampere. Sound complicated? It isn't! It is simply expressed in another equation that you can readily understand and which we will call equation #4.

$$(4) \text{ POWER (P) = VOLTS (E) x AMPERES (I)}$$

A 100 watt lamp in your home draws slightly over 8/10 of an ampere (exactly .833). Thus if we substitute in the power equation assuming 120 volts potential at our homes, then

$$P = 120 \times .833 = 100 \text{ WATTS}$$

Possibly you don't think of a lamp as doing work, but it truly does. It develops heat, although its primary function is to emit light from its filament. Other types of resistors do not supply light, but only heat. The heating element in a percolator never creates light, but does its work by transferring heat directly to water. In electric ranges or ovens we can see a cherry red glow as the dinner meal is being prepared. Whether heat or light is produced, work is being done just as effectively as if the current were turning a motor in a disposal, a food mixer, a vacuum cleaner, or a power saw.

Heat and light are measured in watts, mechanical energy as produced by an electric motor is expressed in horsepower. To establish a relative sense of values between watts and horsepower, one horsepower is equivalent to 746 watts.

# Part X

## Alternating Current

In the early days of this industry most power was direct current (D.C.). It gave way to alternating current because of the limited distances over which it could be transmitted efficiently at the voltages then available. In contrast, alternating current (A.C.) permits efficient transmission of huge blocks of power between distant cities and generating plants. We shall not devote space in these writings to the design of generators but will explain how alternating currents and voltages are created. In the fifth paragraph of the section on Magnetism we mentioned that if a conductor were caused to cut across the earth's magnetic field, a measurable voltage and current could be detected between the ends of the wire. Unfortunately, while the earth's magnetic field is adequately strong to actuate a compass, it is too weak to be used in the generation of power. Man, however, learned how to make powerful magnets to create a strong enough magnetic field to generate substantial amounts of power.

Reference to Figure 1, 2 and 3 will assist in understanding how a man-made generator can create electric current.

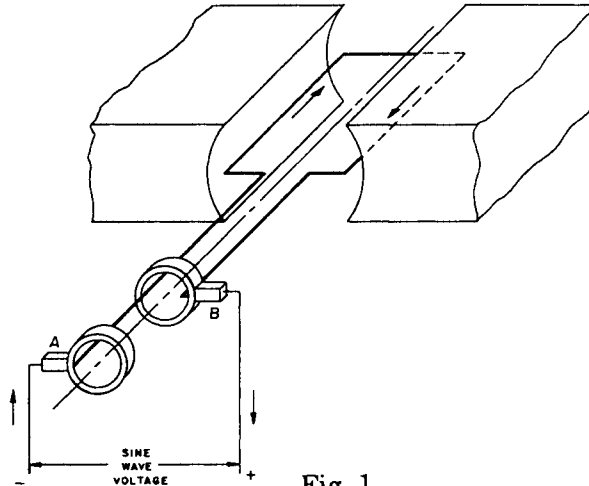

Fig. 1

The large members on the left and right represent powerful magnets between which invisible magnetic lines of force (flux) pass horizontally. The balance of the diagram consists of a wire loop, rectangular in form, each end of which is connected to "slip rings" A and B. Assume further that the rectangular loop of wire is rotating on its own axis 3600 times per minute or 60 revolutions per second in a clockwise direction as viewed from the slip ring. If the flux lines passed from the left pole to the right pole, then at the instant the wire is in the position shown, the current in it would flow from front to back. Also at this precise instant of time, the wire is cutting the maximum number of magnetic lines of force thus generating the highest voltage and current. Simultaneously the wire partially concealed by the right pole is moving through the same flux field but in the opposite direction. This causes the generated current to flow from the back to the front. Thus the currents are in the same direction in the loop and assist one another. At this instant in time slip ring "A" is negative and "B" is positive.

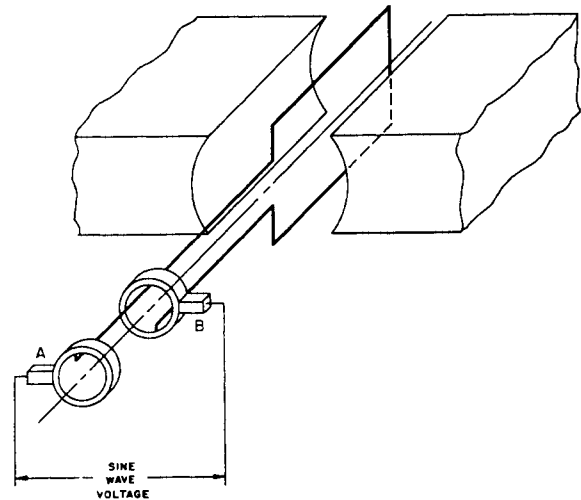

Fig. 2

A look at Figure 2 shows a condition one quarter of a revolution later.

At this instant the top and bottom conductors are passing between lines of flux. Thus no voltage or current is being generated. In Figure 3 another revolution has elapsed so apparently we are under the same condition as in Figure 1. However, there has been a change! Even though the current direction is as before, note carefully that the slip ring "B" is now connected to the left side, therefore it has changed from position to negative.

At any point between 1 and 2, the magnitude of the generated current (or voltage) is getting smaller and smaller as fewer and fewer lines are cut until zero current is reached as in 2. Between 2 and 3, the current builds up and this phenomenon repeats itself 120 times every second.

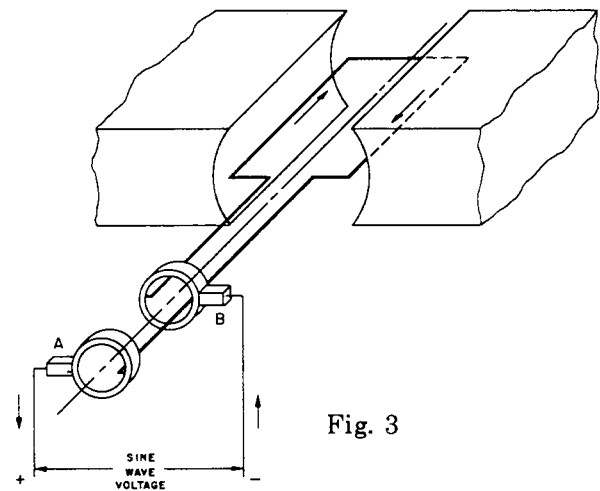

Fig. 3

The net result is voltage, or a current wave that creates a picture as in Figure 4.

In the verbal explanation of zero or maximum currents and voltages we selected only two positions of the flat coil. The circled numbers 1, 2, and 3 represent the voltage generated in Figures 1, 2 and 3. Obviously there are theoretically an infinite number of positions in any revolution, but for our purposes we will select positions only every 30 degrees around the full circle of rotation. When these points are plotted they create a smooth curve that is known as a "sine wave."

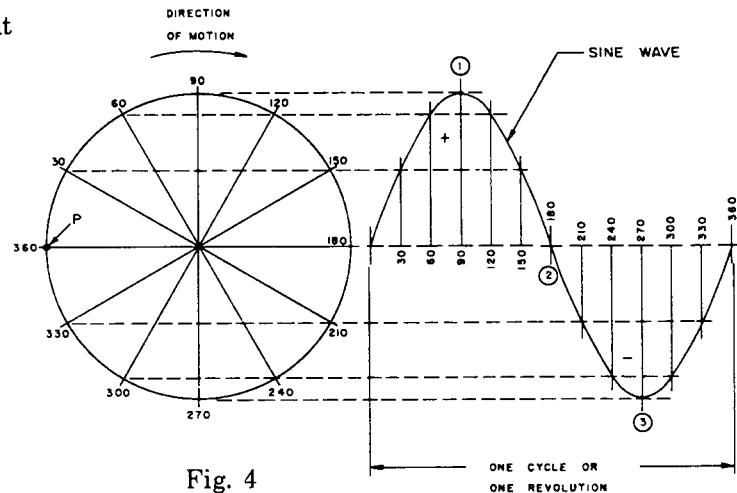

Fig. 4

It just happens that this shape of curve is identical to another curve drawn from the "sine" functions in trigonometry.

The maximum value or height of the voltage wave is dependent upon the constant speed of generator rotation and the strength of the magnetic field. For example, if the distribution system was designed for 2400 volts between the high voltage wires out on the line, the plant operator could increase the magnetic field current enough to boost the voltage on the plant bus to 2450 volts. This would assure him that out at the end of a long distribution line, the last customer's transformer would receive a voltage adequate to provide the house voltage within the limits set by the Public Service Commission.

Why do we call this a 60 cycle wave? Simply because when the generator turns at its rated speed it will produce exactly sixty identical curves that repeat themselves each second. Hence a cycle is one complete wave which, when it begins to repeat itself, is the start of a new cycle.

Many years ago most plants were 25 cycle systems. Because a light bulb actually tries to go out each time the current passes through zero, many persons were annoyed by a flicker they could observe. At sixty cycles no flicker is discernible. Many foreign countries still use 25 cycle systems and our neighbors to the north had such systems in the late forties and early fifties. If any 25 cycle systems still exist in this continent they are certainly the exception and could not be interconnected with modern 60 cycle systems.

## Part XI Transformers

Now that a few basic fundamentals are behind us, we will begin to get into the "meat" of this publication. The very existence of an A.C. power system is dependent upon the availability of transformers. Without them it could not operate. Before details are developed some generalization is appropriate. A transformer is an A.C.



device capable of converting or transforming (hence its name) any A.C. voltage to a different A.C. value, either higher or lower. In the process it also changes current to lower or higher levels and this is the crux of its usefulness in high voltage transmission.

If all the power used by industrial, commercial and residential customers were transmitted at the utilization voltage of 480, 240 or 120 volts, the system would be exorbitantly expensive to operate. The nation would not have the low cost electricity so essential to our economic success. Remember that power = volts x amperes. When the voltage is low, the current to deliver large blocks of power must be very high. Conductors to carry the current would be very large, extremely costly and difficult to handle. Furthermore, the distribution line losses would be out of this world!

Let's have some fun with equations 4 and 2!

$$P = EI \text{ (4)}$$

$$E = IR \text{ (2)}$$

If we substitute #2 into #4 we get

$$P = IR \times I \text{ or } I^2 R$$

Since heat losses represent power loss in transmission and because all conductors do have resistance, look what happens! The power losses go up as the square of the current and directly as the resistance. Do you see what occurs? Whenever the current is doubled, the losses are not doubled. They are quadrupled! Three times the current results in nine times the losses.

In our homes the electric ovens, ranges and driers operate at 240 volts. If the energy were transmitted all the way from the generating plant to your home at 240 volts instead of 2400 volts, the current in the distribution lines would be ten times as high! Because losses vary as the "square" of the current, and the ratio of the current required as the two voltages discussed is  $\frac{10}{1}$  then the losses would be  $\frac{100}{1}$  or 100 times as high! At 7200 volts, a more common distribution voltage, the voltage ratio would be  $\frac{30}{1}$ , the current ratio  $\frac{30}{1}$  and the loss ratio  $\frac{900}{1}$ . A significant number of utilities are now building distribution lines to operate at 15,000 volts, not only to save losses but also to expand the area that can be served effectively from a substation.

Remember that equation #2 stated  $E = IR$ . This also has an effect on the voltage drop in a distribution line. Remember, the utilities are required by law to deliver power to your home or industry at a specified level plus or minus a few volts. Because the lines have resistance (R) and carry current (I) all that is necessary to determine the voltage drop from source to home is to multiply the current times the resistance. If the voltage is 7200 instead of 2400 (a ratio of 3) then only one third the current is needed to operate your range. Because  $E = IR$  they will experience only one third the voltage drop in the lines, so you could go almost three times as far and still have satisfactory voltage at your home. Or, they could handle three times the power with the same voltage drop! It now becomes apparent why transformers are such a vital part of an electrical system.

Whether your urban community is served overhead or underground, you would rarely have to walk more than 200 feet to find the transformer that quietly and efficiently reduces the distribution voltage to the safe utilization voltage so essential to your home. So you see, the utilities always endeavor to transmit their power as close to the point of need at the highest voltage that is practical in order to reduce voltage drop and losses.

## Part XII More Definitions

The more experienced reader will recognize we have deliberately omitted certain variables to keep the story simple. To the beginner we must take one step at a time to avoid confusion. In A.C. systems the conditions are more complex but we will never bring up a new concept unless it has a purpose in explaining something that will arise later. We will now add a few more definitions to our present list.

I = Current expressed in amperes	Kva = 1000 volt amperes (apparent power)
E = Voltage expressed in volts	PF = Power Factor $\frac{Kw}{Kva}$
R = Resistance expressed in ohms	XL = Inductive Reactance (ohms)
P = Power expressed in watts	Primary Voltage – Distribution or Transmission voltage
IR = Voltage drop expressed in volts	Secondary Voltage – Utilization voltage
K = Thousand	Flux – Magnetic lines of force
Kv = 1000 volts	Primary winding – A transformer winding connected to power source
Kw = 1000 watts	Core – The path for magnetic flux

## Part XIII

# Electromagnetism

At the outset we mentioned that the world was a huge permanent magnet. Lodestones found on the earth are also permanent magnets. Man, however, learned to make a permanent magnet and an electromagnet. We will devote our attention to electromagnets.

It was learned many years ago that if D.C. current flowed through a wire, magnetic flux was established around the wire. When the current was shut off, the flux disappeared or collapsed. The direction the flux rotates around the wire is definitely related to the current direction. Thus if we reverse the current in the wire, the flux changes direction. If we did this repeatedly in short intervals of time, it would approximate or simulate the effect of an alternating current flux field.

It was just a matter of time until it was learned that if an insulated wire was closely wound on a paper tube and energized, the tube became a magnet, one end of which was a north pole and the other a south pole. Furthermore, if an iron or steel core were slipped into the hollow tube an even more powerful magnet resulted. This indicated that if flux had a choice, it would prefer to go through iron or steel rather than through air. In other words, air has a higher "reluctance" to the passage of flux than does iron. It was later determined that iron had at least 10,000 times the permeability" of air in carrying flux. In fact, the degree of ease with which a core is magnetized is known as permeability. It is related to air which has a rating of one.

Can't you just picture one of the pioneers asking himself "If I can create flux by passing current through a coil, is it likely that if I wrapped another wire coil around the first one that this same flux would create current and voltage in the second winding?" He was so right; he had discovered the principle of a transformer! He could generate electric current in a winding that was not electrically connected to the original energized coil.

Logic and continued experimentation proved that the use of an iron core, shaped into a continuous loop, created an even better transformer. Also, if desired, the primary winding could be on one leg of the core and the secondary on another part of the magnetic circuit as in Figure 5. In other words, the iron core provides a very easy control path in which the flux can flow.

If no load were connected to the secondary winding, a voltmeter would indicate a specific voltage reading across the secondary terminals. If a load were applied the voltage would drop, and if shorted the voltage would be zero. Since there seemed to be a relationship between the flux in the secondary and the voltage that it indicated, did the amount of flux change in the core within the secondary winding? The answer was yes. With an opened circuit secondary (no load) all the flux links both windings. As load is added, or a short is applied, the secondary flux reduces and finally disappears. Where does it go? It still exists in the primary so the rest of it must be forced out of the core as "leakage flux." This can actually be demonstrated with iron filings placed close to the core which clearly shows the change in the flux pattern. What actually happens is that as the current flows in the secondary, it tries to create its own magnetic field which is in opposition to the original flux field. This like a valve in a water system, restricts the flux flow forcing the excess to find another path, either through air or in adjacent structural steel as in core clamps or supporting angles. The unit in Figure 5 is known as a high leakage flux transformer as compared to a low leakage design in Figure 6 where the coils are wound around each other. No added explanation of Figure 6 is needed as the reader can readily observe the differences in the flow of the flux lines.

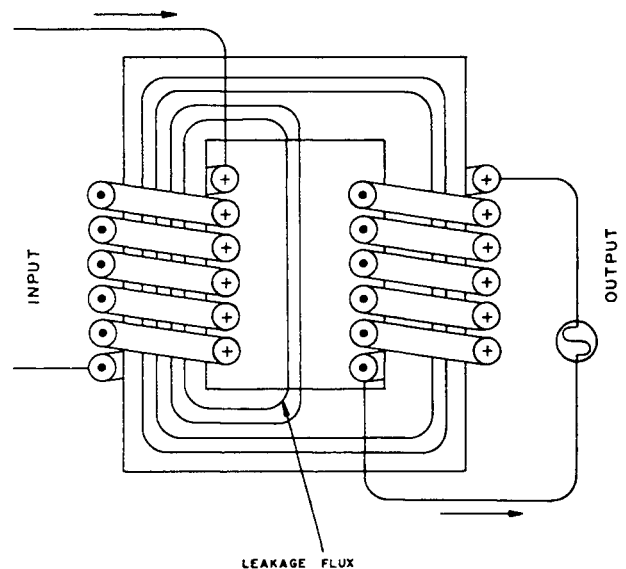

Fig. 5

## Part XIV Transformation Ratio

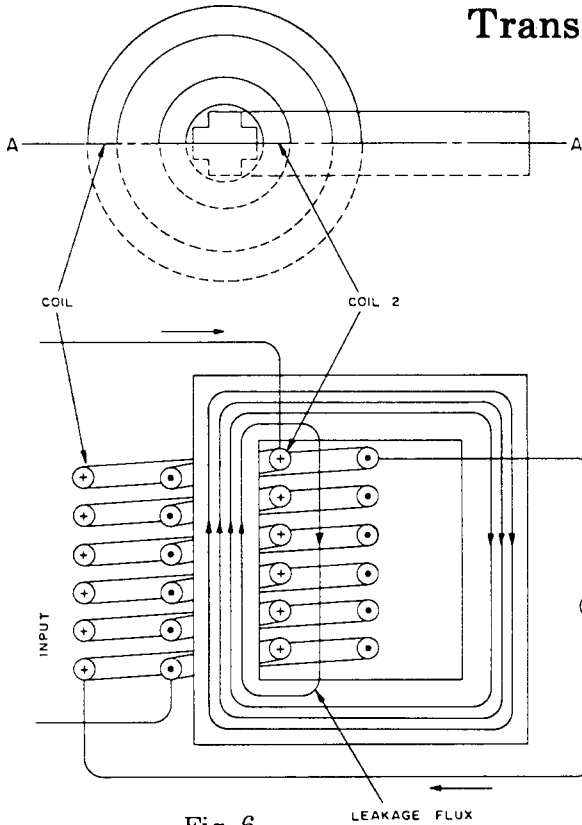

Fig. 6

Let us return again to Figure 5. If the secondary carried no load, and the returns on each winding were identical in number, a voltmeter on the secondary terminals would show the same reading that exists on the primary terminals. Thus, it is a 1 to 1 ratio transformer.

If only half as many turns are on the secondary, only half the voltage will exist on the secondary, and this then becomes a 2 to 1 ratio unit which we could call a step-down transformer (high to low voltage). What happens to the current if a load is applied? Will it also be cut in half? No! Just the opposite. Ignoring small losses in the transformer, this secondary would provide twice the current as would be present in the primary.

This is logical as can be shown with the power formula  $P = EI$ , which was explained in Part 9, equation #4.

Because the primary winding furnishes all the power, and practically none of it is lost in the transformer, then the power out must equal the power in. Therefore, since the secondary voltage is half as great, the current must be twice as large.

What else does this tell us? That in a step-down transformer the conductor size in the secondary must be larger than in the primary in order to carry a greater amount of current.

These facts are true of a tiny bell ringing transformer in your basement, or a giant 50,000 KVA transformer in a generating station switchyard.

Now, does the miracle of a transformer become truly evident? Without any moving parts we can change very high transmission voltages to levels that make electricity safe to use in factories and homes.

## Part XV Power Factor

It probably is better that you have a more intimate understanding of Power Factor than the simple expression we showed in the last group of definitions. This equation which we will call #5, was

$$(5) \text{ PF} = \frac{\text{Kw}}{\text{Kva}}$$

To take this step we must grasp that there are three different factors in an A.C. circuit.

1. True Power
2. Inductive Reactance
3. Capacitive Reactance

An analogy will enhance understanding. Imagine a farm wagon on a country road to which three horses were hitched, as in Figure 7.

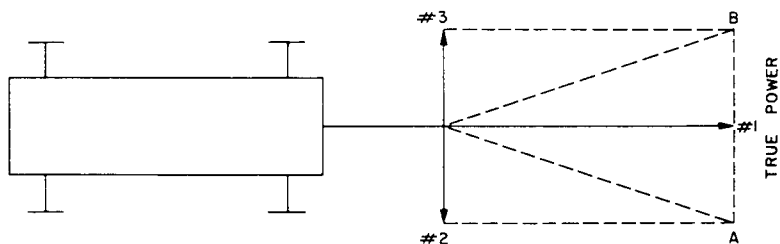

Fig. 7

The one in the middle, a stallion, is pulling straight down the road . We'll call him "True Power" because all his effort is in the direction that work should be done. The one on the right #2 is a fickle small animal. He always wants to nibble at the daisies on his side of the road. He doesn't contribute an ounce of pull in the desired direction but causes havoc by pulling us toward the ditch. We'll call him Mr. Inductance. The third horse, about the size of #2, is 180 degrees out of phase with #2 and seems to enjoy the succulent grass on the left side. He is as opposite from #2 as north is from south. He also has a right angle complex and contributes nothing to forward motion. We'll call him Mr. Capacitance. Incidentally, we would never have #2 or #3 hitched to our wagon if we were analyzing a D.C. circuit. They just can't exist in a D.C. Society.

For the moment we'll forget #3. If only #1 and #2 were pulling, the wagon would go in the direction of the dotted line A. Notice the length of that line is greater than the line to #1, so Mr. Inductance has an effect on the final result. The direction and length of A might well be called "apparent power" and happens to be the hypotenuse (or diagonal) of a right angle triangle.

If #2 were left at home, then #1 and #3 in combination would pull towards B and the length of that line would also be "apparent power." If all three were on the job, #2 and #3 would cancel one another, and the only useful animal is reliable #1.

In an A.C. circuit we always have all three forces in the picture in varying length. We should not complain about inductance for it is always present in every magnetic circuit and always works in a 90 degree angle with True Power. Without magnetism we would have no motors or transformers.

## Part XVI Vectors

A vector is a line with direction and length. Our industry used this language long before the airlines adopted it to guide a plane to a specific zone or airfield when flying blind in foggy weather. Vectors are like reading a road map and not much more difficult, just a bit more refined. Road directions that told you to go east 40 miles, then south 30 miles and you will reach your destination, are simple to understand. This would have required 70 miles of driving to get to our destination, but had we been able to drive as the crow flies, our distance traveled would have been only 50 miles. Those who know what we are coming to would have recognized the classical 3, 4, 5 triangle or the 80 percent power factor relationship. In our industry, vectors are considered to be rotating as the hands of a clock which runs backwards or in a counter clockwise direction. Vectors usually have arrows on them to indicate their direction.

Figure 8 changes the wagon and horses in Figure 7 to a relationship that will be useful as we proceed.

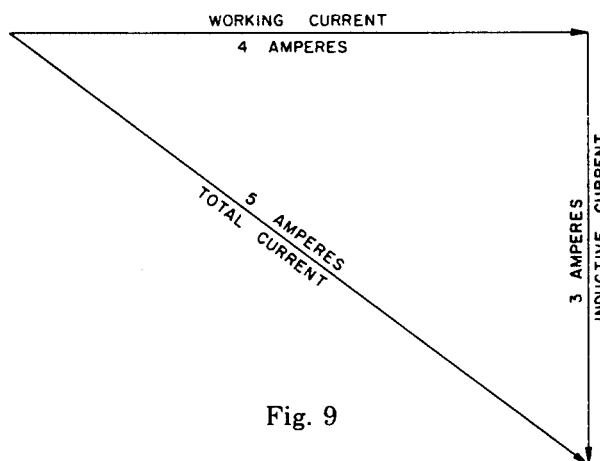
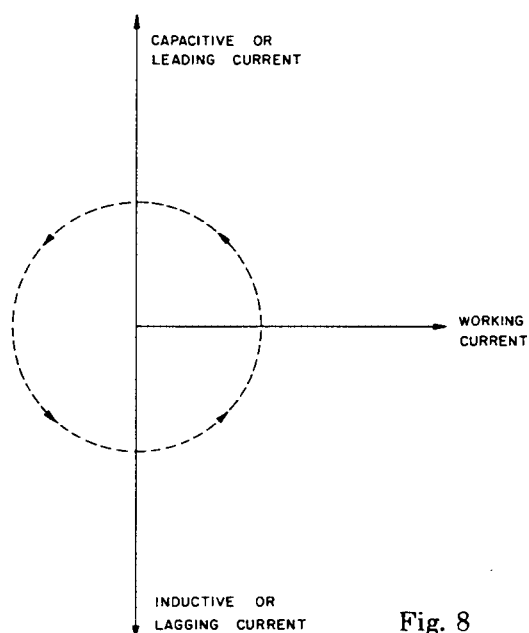

With counter clockwise rotation, note that inductive current lags behind working current. The voltage drop across a resistance, an inductance, or a capacitance assume the identical relative position.

In Figure 9 we will combine the current through a resistance with the current through an inductance so you will see why we cannot add their individual values arithmetically.

If AB was 4 amperes and BC was 3 amperes, then the diagonal line AC (hypotenuse of a right angle triangle) will be 5 amperes. You could prove this to your satisfaction by drawing the values to scale. Mathematically we get the same result by applying the right angle triangle rule which states the hypotenuse is equal to the square root of the sum of the squares of the other two sides, or  $\overline{AC}^2 = \overline{AB}^2 + \overline{BC}^2$

$$\text{Thus } \overline{AC}^2 = 4^2 + 3^2 = 16 + 9 = 25$$

$$\text{Therefore } AC = 5$$

In this example the working current which is related to kilowatts (KW) and the total current, related to KVA, are in the ratio of  $4/5 = 0.80$ . We mentioned in Part 15 under Power Factor that  $PF = \frac{KW}{KVA}$ . Thus, this circuit would have a power factor of 80 percent ( $0.80 \times 100$ ).

## Part XVII Voltage Drop

Figure 10 shows a simple 100 percent power factor circuit in which a 1 ohm resistance appears between the source of power and the load. The current in this series circuit is 10 amperes and the voltage at the source is 120. Because Ohm's law reminds us that  $E = IR$ , we must have a voltage drop across the resistance equal to 10 times 1, or 10 volts. With voltage and current in phase, only 110 volts will be available at the load because we must subtract the resistance drop from the source voltage.

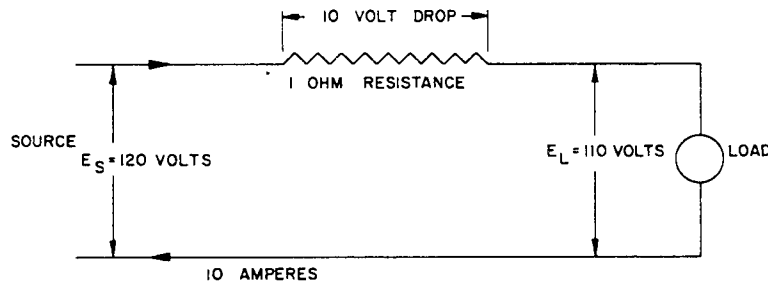

Fig. 10

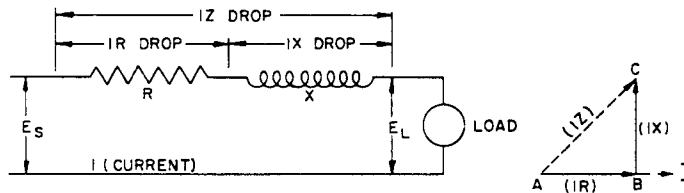

Fig. 11A

It is not quite as simple when inductance is introduced into the circuit as in Figure 11a. The load voltage will be equal to the source voltage minus the voltage drops through  $R$  and  $X$ , but they cannot be added arithmetically! The little diagram at the right should remind you of the horse and wagon analogy previously given in Figure 7. The dotted line  $AC$  is the combination of the two voltages across  $R$  and  $X$  and represents the voltage drop in the line only.

Because your sales effort rarely will require the development of voltage diagrams with your customers, we will show the final effect of the line drop in Figure 11b. It can be seen that the line  $GA$ , which is the load voltage  $E_L$ , is less than the source voltage  $GC$ , due to the voltage drop in the line  $AC$ . Because of the effect of the reactance in the line, we cannot subtract this voltage drop arithmetically from the source voltage to obtain the load voltage.

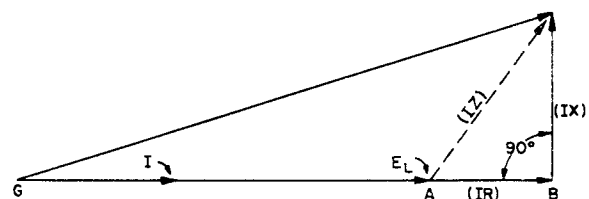

Fig. 11B

## Part XVIII Cores

Now that we have a better grasp of some basic fundamentals, it is timely to discuss transformers and more specifically, the core itself.

Part 13 illustrated core and coil combinations in Figure 5 and 6 under the heading of "Electromagnetism." Special core steel is used to provide a controlled path for the flow of magnetic flux generated in a transformer. The core is not a solid bar of steel, but is constructed of many layers of thin sheet steel called laminations.

While the specifications of the core steel are primarily of interest to the transformer design engineer, the salesman selling transformers should at least have a conversational knowledge of the materials used.

Most of the steel used for laminations in our plants are known as M-6. It is .014 inches thick or more commonly called 29 gauge. It is processed from silicon iron alloys containing approximately 3-1/4% silicon. The addition of silicon to the iron increases its ability to be magnetized and also renders it essentially non-aging.

The most important characteristic of electrical steel is core loss. It is measured in watts per pound at a specified frequency and flux density. The core loss is responsible for the heating in the transformer and it also contributes to the heating of the windings. Much of the core loss is a result of eddy currents which are induced in the laminations when the core is energized. To hold this loss to a minimum, adjacent laminations are coated with an inorganic varnish.

Cores may be of either the "core type" or "shell type" construction. Most Square D three phase transformers are of core type construction as illustrated in Figure 12. A shell type is shown in Figure 13.

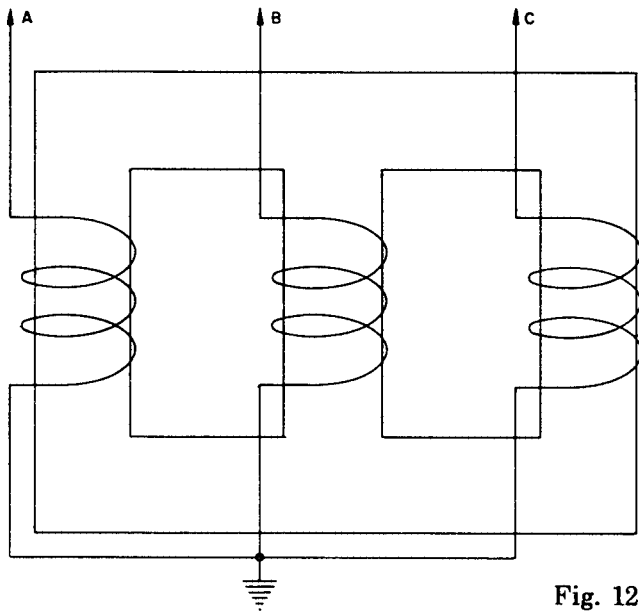

Fig. 12

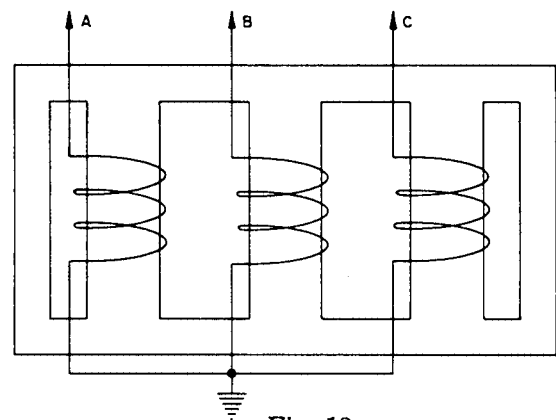

Fig. 13

There are a number of reasons favoring core type construction including:

1. Only three core legs require stacking thus reducing cost.
2. Steel does not encircle the two outer coils providing better cooling.
3. Floor space is reduced.

## Part XIX

### Butt, Wound, And Mitered Cores

The old adage that a picture is worth a thousand words justifies an illustration for each of the three fundamental types of core construction. The butt core, also known as "butt and lap" is shown in Figure 14.

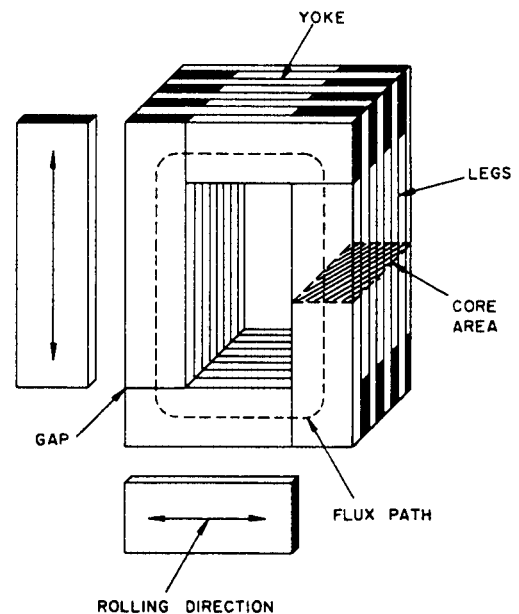

Fig. 14

Note that only two sizes of core steel are needed due to the lap construction shown at the top and right side of the illustration. For ease of understanding, the core strips are shown much thicker than the .014 inches mentioned several paragraphs previously. Each strip is carefully cut so that the air gap indicated in the lower left corner is as small as possible. You will recall that the permeability of steel to the passage of flux is about 10,000 times as effective as air, hence the air gap must be held to the barest minimum to reduce the ampere turns necessary to achieve adequate flux density. Also, the amount of sound that emanates from a transformer due to magneto-striction is a function of the flux density and this poses an interesting difference between this construction and the mitered core which we will discuss under that heading.

Another phenomenon in core steel is that the flux flows more easily in the direction in which the steel was rolled. Even this characteristic is different in hot rolled versus cold rolled steel. For example, the core loss due to flux passing at right angles to the rolling direction is almost 1-1/2 times as great in hot rolled and 2-1/2 times as great in cold rolled when compared with the core loss in the direction of rolling. The difference in exciting current is more dramatic, with ratios of two to one in hot rolled and almost 40 to 1 in cold rolled. These are primarily the designer's concern, but at least you know now that there is a difference.

We previously mentioned that "eddy currents" are restricted from passage from one lamination to another due to the inorganic insulating coating. However, the magnetic lines of flux easily transfer at adjacent laminations in the lap area but in so doing are forced to cross at an angle to the preferred direction.

## Part XX Wound Cores

Because of these unique characteristics of core steel, some core designs were made that took advantage of these differences. One such type is shown in Figure 15. The core loops are cut to pre-determined lengths so that the gap locations do not coincide. These cuts permit assembling the core around a pre-wound coil which passes through both openings. Another design, now discontinued because of unfavorable cost, used a continuous core with no cuts. Separate coils had to be wound on each of the vertical legs of the completed core, a costly process which made this design non-competitive.

Because we do not use wound cores, we will not devote more space to the many variations of design used by oil-filled transformer manufacturers.

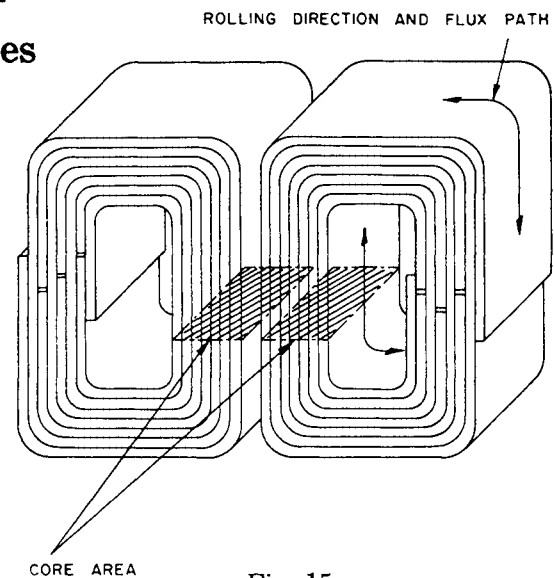

Fig. 15

## Part XXI Mitered Cores

Figure 16 is an example of this design. In effect, it is a butt lap core with the joints made at 45 degrees. There are two benefits derived from this type of joint. One, it eliminates all cross grain flux and hence improves the core loss and exciting current values and two, it reduces the flux density in the air gap resulting in lower sound levels. It is only used with cold rolled, grain oriented steel and permits this steel to be used to its fullest capability.

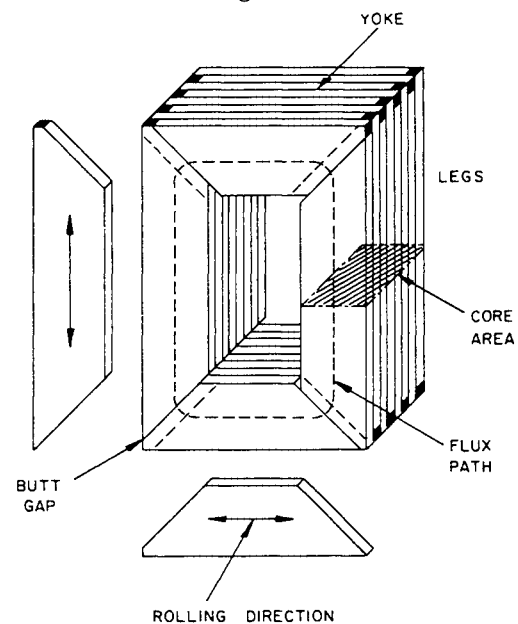

Fig. 16

## Part XXII

### Coils

Now that we understand the purpose and construction of a magnetic core in a transformer, let's study how this core is put to work. In Parts 13 and 14, we developed how and why a transformer, without any moving parts, is able to receive alternating current energy from one voltage source and convert it to another voltage useful to industry and home. The first type of unit we will be discussing is the construction known as the "insulating" transformer. Later on, we will devote time to the "auto transformer." Either type, of course, requires some form of coil or winding.

## Part XXIII

### Insulating Transformers

This type of unit represents the majority of transformers produced by Square D. They are typical of the types described in Pages 2 to 10 of our Bulletin D-1D "Dry Type Transformers 600 Volts and Below." Do not be confused if you see the term "isolating" used to describe some of these transformers. "Insulating" and "isolating" both mean that there is no internal electrical connection between the primary and the secondary windings.

In all but a few designs, which are in the specialty classification that require very low reactance (low leakage flux types), it is customary for us to first wind the low voltage coil next to the core and after it is completed, finish the unit by winding the high voltage coil over it. This construction places the conductors energized at the high voltage a greater physical distance from the magnetic core which is normally grounded. The core is electrically interconnected with core clamps, steel structure and enclosing case, all of which are connected with a ground lead to the plant or system ground.

In the customary Square D high - voltage design, the lower voltage coil is wound next to the core. This is covered with mica sheet layer insulation over which the high - voltage coil is wound. Additional sheet mica insulation is applied around each coil with a final wrap of glass tape for extra electrical and mechanical strength. This is commonly known as "barrel" type construction with a 220° C. insulation system.

Cooling ducts are strategically placed within each winding to carry away the internally generated heat. The smooth exterior coil surfaces in a vertical plane minimize the accumulation of dirt.

With this construction the high voltage winding is at the optimum distance from the grounded core for maximum electrical integrity.

This design is in contrast to another type used in large power transformers in which a series of disc or pancake coils are employed with each section in a horizontal plane. These horizontal surfaces invite the accumulation of dirt and dust which over a period of time degrades the insulation especially when in a humid environment. We do not use this construction in our units.

The barrel type coils have excellent mechanical strength, permit lower cost and require minimum floor space.

## Part XXIV

### Short Circuit Stresses

You will recall in the early fundamentals that an energized coil creates an electromagnet. We have two such magnets on each core leg. If the primary and secondary windings are not properly "centered" with respect to each other on the core leg there is a tendency for them to telescope in opposite directions when exposed to very severe short circuits. Once movement starts, it most likely will continue to totally destroy the windings.

To minimize the probability of telescoping, coils are designed so that the "electrical center" of the two coils are in an identical position. Secondly, both windings are rigidly clamped in place to prevent the start of this axial force which becomes greater as the centers are separated from each other.

The telescoping problem becomes even more complex when transformers are specified with "taps." Taps are terminals brought out from the electrical winding at one or more locations to effectively change the transformation ratio of the transformer. They may appear on either or both of the windings. Most commonly, they are built into the primary or high voltage winding. When the customer connects to a tap point other than the standard ratio, the electrical center of one of the windings is shifted from the center of the companion winding. This increases the probability of telescoping under fault conditions.



## Part XXV Taps

We have mentioned taps, so let's see why they are necessary and how they affect a change in the transformation ratio. If an electric utility could always guarantee to deliver exactly the rated primary voltage at every transformer location, taps would be unnecessary. It is not possible to achieve this and in recognition to this fact the Public Service Commissions of the various states allow reasonable variations above or below a nominal value.

Generally speaking, if a factory is very close to a substation or generating plant the voltage will consistently be above normal. Near the end of the line the voltage may be below normal. The primary taps are used to match these voltages.

## Part XXVI Wiring Diagrams

To better understand the wiring diagrams on Page 11 of our Bulletin D-1D, a simple diagram or two should clear away any mystery. In Figure 17, assume a 25 KVA transformer rated at 7200 volts to 120 volts. Such a unit might have 1620 turns on the primary (approximately) 4-1/2 volts per turn). Since the ratio of the voltage is 7200 divided by 120 =  $\frac{60}{1}$  we should have only 1/60th as many turns to deliver 120 volts from the secondary, so, -- 1620 divided by 60 = 27 turns on the secondary.

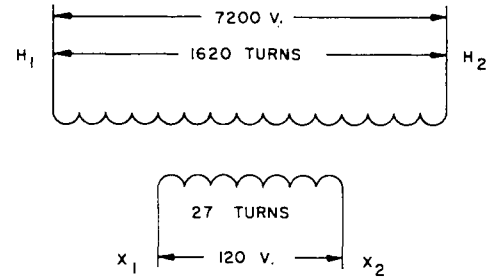

Fig. 17

Figure 18 is more typical of the transformers used to light our homes which require 120 volts to operate our small appliances and lamp bulbs, and 240 volts to supply electric ranges, hot water heaters and well motors. We can do this by adding a second low voltage winding, which will have its terminals marked X3 and X4. By connecting X2 and X3 together and tying them to ground, we can divide our house circuits into two parts, half of which operate between X1 and X2, and the other half between X3 and X4. Because these voltages are on the same single phase core leg, a voltmeter connected from X1 to X4 would read 240 volts and this is the connection used to operate 240 volt loads.

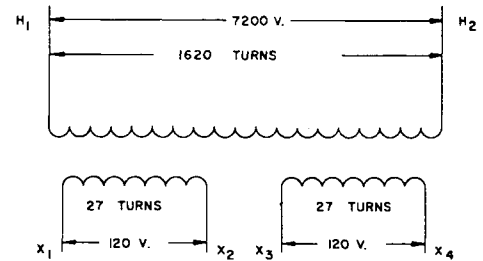

Fig. 18

Now look at Figures 19 and 20. In Figure 19, assume the same 1620 turns exist between H1 and H4. If we placed two new taps closer to H4 as at H3 and H2, and in each instance moved back 40 turns, then between H1 and H2 we would have 1620 minus 80 or 1540 turns. This happens to be 5% fewer turns, so if our source voltage is low by 5%

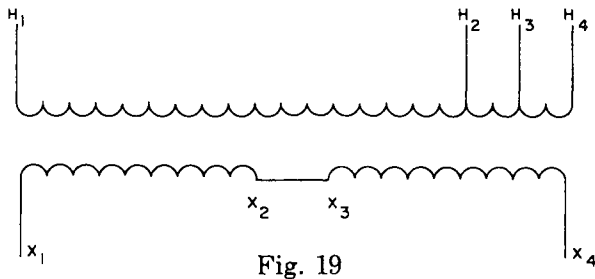

Fig. 19

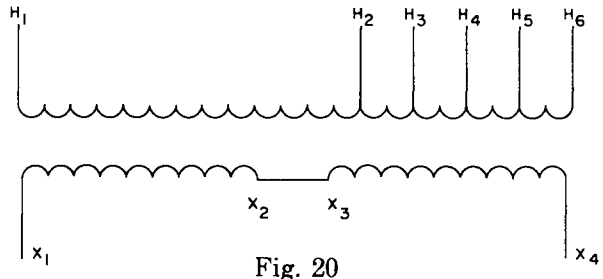

Fig. 20

and we connect the high voltage of only 6840 volts between H1 and H2 (or 5% less than the nominal 7200 volts) we will apply the same volts per turn on the primary as in the original case and will again receive 120 volts from X1 to X2 and from X3 to X4.

If voltage had been low be only 2-1/2%, we would have connected the source between H1 and H3 to deliver our desired secondary voltage of 120. This construction is known as 2-2-1/2 taps below normal and is the method used when primary voltage is lower than normal.

Figure 20 employs similar logic. Note that 80 extra turns have been added on the primary beyond H4. Tap H5 is at the 40th turn and H6 is at the end. Now we have a grand total of 1620 plus 80 or 1700 turns. Therefore, if a plant is close to the substation where voltage is about 5% above normal 7200 (or at 7560 volts) all we need to do is connect the high voltage between H1 and H6 and again the secondary voltages will be at the desired level of 120 and 240 volts.

The arrangement in Figure 20 is described as 2-2-1/2% taps above and below normal. This makes it a very flexible design and is in common usage.

In our catalogs you will observe listed in the "taps" column notations such as 2-2-1/2%FCBN. This simply means that the particular unit has 2-2-1/2% full capacity taps below normal. FCAN means full capacity above normal. The term full capacity means that the primary winding has adequate conductor capability to deliver full nameplate rating of the transformer without exceeding the guaranteed temperature rise.

## Part XXVII

### Convenience Of Tap Connections

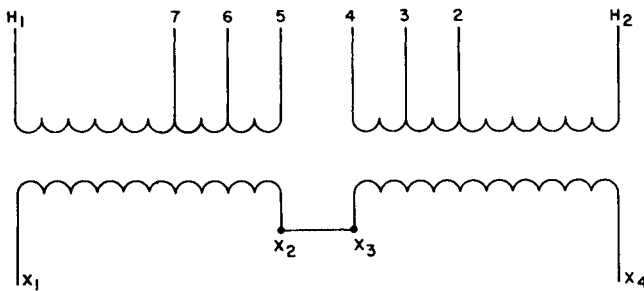

Fig. 21

In large transformers it would be very inconvenient to move the thick, well-insulated primary leads to different tap positions when changes in source voltage levels made this desirable. Hence, Square D uses a convenient method which can be understood by looking at another wiring diagram as in Figure 21.

The permanent high voltage leads would be connected to H1 and H2. The secondary leads, in their normal fashion to X1, X2, X3, and X4. Note, however,

the tap arrangements available at 2, 3, 4, 5, 6, and 7. Until a pair of these taps are interconnected with a jumper, the primary circuit is not completed. If this were the typical 7200 volt primary we have previously used in our examples with a normal 1620 primary turns, we have a starting point for analysis. Assume 810 of these turns are between H1 and 6, and another 810 between 3 and H2, then if we connect six and three together with a flexible jumper on which lugs have already been installed, the primary circuit is completed and we have a normal ratio transformer that could deliver 120/240 volts from the secondary.

Between tap #6 and either 5 or 7, we have the familiar forty turns. Similarly, between #3 and either 2 or 4, we also have forty turns. From what you have learned previously, any of you can see that if we change the jumper from 3 to 6 to 3 and 7, that we have removed forty turns from the left half of the primary. The same condition would apply on the right half of the winding if the jumper were between 6 and 2. Either connection would boost secondary voltage by 2-1/2 percent. Had we connected #2 and #7, 80 turns would have been omitted and a 5 percent boost results. Placing the jumper between 6 and 4, or 3 and 5 would reduce output voltage by 5 percent. It is believed with this background on tap connections you will be able to interpret any of the circuit diagrams in our catalogs.

## Part XXVIII

### Three Phase Power

All large blocks of power at high voltage transmission and at distribution voltage are transmitted three phase. Up to this point we have developed some fundamental concepts relating only to single phase circuits. They will be useful in explaining three phase relationships, because three phase power is in the simplest concept three single phase power sources working together in an orderly and efficient combination.

The reader will recall how the single armature coil shown in Figure I created a complete cycle of current and voltage for each revolution. Picture three such loops to separate slip rings so that loads could be connected to them. In reality we would then have three separate single phase generators wound on a single rotating armature.

By having three separate coil conductors equally spaced around the armature it becomes evident that their voltage waves (as the one shown in Figure 4) will be separated 120 electrical degrees. We could call the wave in Figure 4 as phase A. Then the next conductor, phase B, would start its rise at the 120 degree point and phase C would do the same at 240 degrees.

## Wye (Star) Distribution

It will be easier to understand what happens if we draw the equivalent conditions in a vector diagram as in Figure 23. NA would be the voltage vector for phase A and NB and NC the corresponding vectors for phases B and C. They are spaced 120 degrees in our conventional counter clockwise rotation. By electrically connecting the other ends of these coils at a common point N (common neutral) we create the diagram shown. Because it looks like the letter Y, this is known as the “wye” connection (also star connection).

The diagram creates other valuable information. If the generator produced 120 volts from N to A, it also would from N to B and N to C. If those lengths were drawn to scale and we measured the distance from A to B, B to C, and C to A, they would scale 208 volts which actually is the voltage between these conductors, A, B, and C.

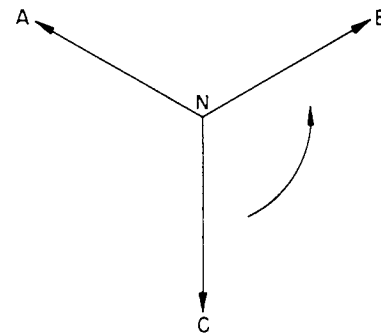

Fig. 23

Deriving these values by drawing pictures is tedious and time consuming. An easier way is to merely multiply the phase to neutral voltage by 1.732 (square root of 3). Thus, if NA was 277, then AB = 480. Similarly a phase to neutral voltage of 2400 creates 4160 phase to phase, and 7200 phase to neutral becomes 12,470 volts. These are voltage combinations that become second nature to persons who talk this language.

One of the benefits wye distribution brings to the utility or municipality is that even though their turbo-generators are rated at 2400 or 7200 volts, they can transmit at a 72 percent higher phase to phase voltage with reduction in losses and better voltage regulation at the ends of longer rural lines. Most rural distribution in the USA is at 12, 470/7200 to gain this benefit. In these systems, the neutral junction point is grounded and a fourth wire is carried along the system and grounded at every distribution transformer location. This solidly grounded wye is regarded as the safest of all systems and also provides the best assurance of proper operation of protective devices needed to isolate sections of a system in case of trouble.

## Delta Distribution

This was the pioneer distribution system. The vector diagram for it is shown in Figure 24. The generator windings are connected as shown and the junction points identified as phase A, B, and C. Only three wires appear on the distribution system. Because none of the three lines are usually connected to ground an artificial ground midway between the three points of the triangle tends to exist. It is free to shift when the loads on each phase are not equal. If a measurement was made to ground the value would be the phase to phase voltage divided by the square root of 3. For 7200 volts phase to phase, the reading to ground would be 4160 volts.

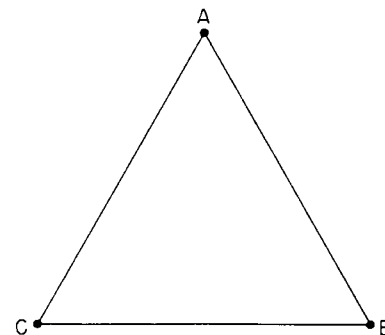

Fig. 24

In either wye or delta systems three phase transformers are connected to phase A, B, and C. Single phase loads on wye systems are usually connected from phase to neutral or they could be fed between the phase wires if high voltage transformers were available. In the delta system single phase loads are always connected between the phase wires.

A connection possible in three phase delta systems is known as “open delta.” It permits the availability of three phase power anywhere along the distribution line with the use of only two transformers rather than with the usual three units. It reduces capital investment and adds only one penalty. The three phase load that can be carried by an open delta bank is only 86.6 percent of the combined rating of the two equal sized units. It is only 57.7 percent of the nominal full load capability of a full bank of transformers. In an emergency however, this capability permits single and three phase power at a location where one unit burned out and a replacement was not readily available. The total load must be curtailed to avoid another burnout. This discussion was presented to provide a better understanding of why the tables on Page 14 of Bulletin D - 1D limit the load KVA to less than the nameplate ratings for open delta application.

## Grounded Delta Banks

When delta banks are not grounded, it is possible for one phase to accidentally become grounded without the operators being aware of this. Not until another phase also grounds out will the problem be apparent. A few companies deliberately ground one corner of their delta system so that inadvertent faults on the other two phases will cause fuses, reclosers, or breakers to clear the fault.

At least one very large company and a number of smaller ones ground the midpoint between the two phases. It permits some interesting voltage possibilities as shown in Figure 25. Three phase power is available as normal between A, B, and C. Single phase 240 volt can be had between any pair of phase conductors. Single phase 120 may be connected between ground and either B or C phase. Finally, 208 volts single phase power is possible between ground and A phase. Most of our readers will never be exposed to this concept, but at least they are aware of its existence should such a system be in their field of operations.

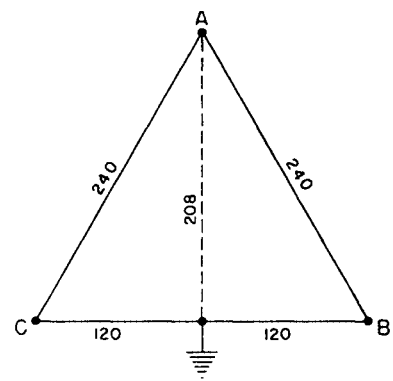

Fig. 25

## Part XXIX

### Buck And Boost Transformers

The buck and boost transformer is a very versatile unit for which a multitude of applications exist.

The name fully defines its function, but before we get into its applications, a few words of its electrical capability are desirable. It is suggested this discussion will be easier to understand if you first read the information shown on Pages 12 and 13 of Square D Section 1000/Bulletin D - 1D.

Refer to the wiring diagrams on Page 12. The high voltage winding between H1 and H2 is designed to operate at 120 volts. H3 and H4 terminate a second primary winding also rated at 120 volts. There are 10% as many turns on each of the secondary windings as there are on each primary winding. Therefore, when H1 and H2 are connected to a 120 volt source, X1 and X2 will deliver 120 divided by 10, hence 12 volts. The same conditions apply between X3 and X4. You have also noted for the first time, that the H2, H3, and X2, X3 leads criss-cross each other in the diagram but are not connected together. We purposely did not show this arrangement in our earlier diagrams to avoid confusion when discussing theory. It just so happens that the relative positions at which these terminals come out of the coils on larger transformers with terminal boards and lugs is as shown on Page 12. If we connect H2 and H3 together, a continuous primary circuit exists between H1 and H4.

The diagrams also demonstrate what occurs with different combinations of external connections by our customers.

In the small buck and boost units terminal boards and lugs are not feasible, therefore, only the leads are brought out of the windings and identified with H and X numbers to assure proper customer connections.

In all transformers, the H terminals are always the high voltage terminals, and the X terminals always the low voltage. Either can be designated primary or secondary depending on which is the source, and which is the load.

## Part XXX

### Easy Selector Chart

Studying the chart on Page 13 in Bulletin D-1D, you may have been amazed, and wondered why, an auto transformer could handle a load so much greater than its nameplate rating. For example, notice that the sixth column to the right headed by catalog number 1S43B indicated ability to handle a 10 KVA load, when the voltage boost was 10 percent. Yet, as you checked the catalog number you found on Page 12 that the nameplate rating of this unit was only 1 KVA. How can this be? We'll take you through a three step procedure that pictures what happens.

Assume first we have a 1 KVA (1000 VA) insulating transformer, 120/240 - 12/24 volt. The primary current equals 1000 divided by 240 or 4.166 amperes. We'll call it 4.17 amps. Because the transformation ratio is 10 to 1 the secondary amperes will be 41.7 amperes. In Figure 22A, we show a 240 volt source at the left that delivers 10 KVA, but the secondary winding of the 1 KVA transformer has been placed in series with the line to the load.

Let's see what this does! Remember  $P = EI$ . We can rewrite this  $KVA = KV \text{ times } I$ , or also  $I = KVA \text{ divided by } KV$ . Therefore, by substituting  $I = 10 \text{ over } 0.24 = 41.7 \text{ amperes}$ . Thus the current from the source is 41.7 amperes. As we said at the beginning of this paragraph, our 1 KVA transformer at full load has a secondary current that also is 41.7 amperes. Therefore, there is no harm in putting it in the line because its secondary current rating is adequate

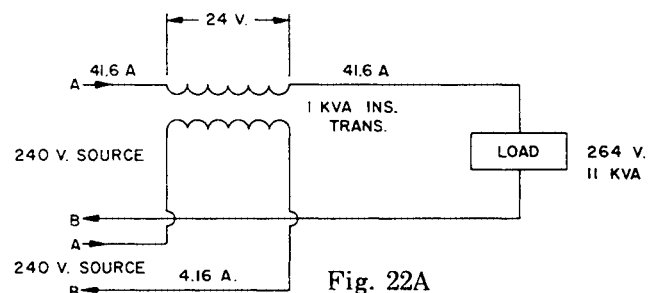

Fig. 22A

to handle the load current. Because we started with 240 volts at the source and now add 24 to it, the load actually sees 264 volts. It so happens that the load is  $KVA = 41.7 \text{ times } .264 = 11 \text{ KVA}$ , 10 of which comes from the source and the extra 1 KVA from our booster secondary. The total drain from the line is 41.7 amperes plus 4.17 or 45.87 amperes. It is sort of ridiculous to bring out four leads to go to our source so let's see if it can be simplified!

In Figure 22B, we've done just that! Since the two source lines Marked A in Figure 22A are the same point and the two B's are identical, why not connect them together as at X and Y. The connections are identical to 22A except now we have only two lines to the power source, hence the currents are as shown.

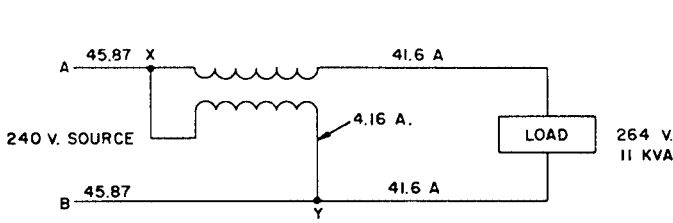

Fig. 22B

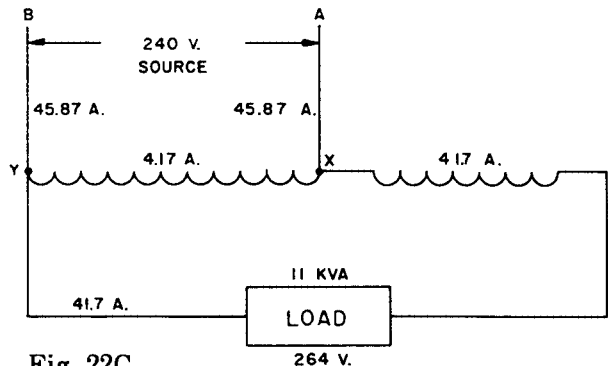

Fig. 22C

But this diagram doesn't look like the No. 2 wiring diagram in our Bulletin D - 1D on Page 12 which appears to be very simple. Actually, they are identical as can be seen in Figure 22C. It now becomes evident that engineers are perfectly safe in taking a little 1 KVA transformer and connecting it into a higher voltage supply current so that it's secondary winding is actually carrying the current to supply an 11 KVA load!

Those readers who have been very observant noticed that our "easy selector" chart on Page 13 of D - 1D instructs users to limit the load KVA for catalog No. 1S43B to 10 KVA. Why? Because when the source voltage is less than 240 volts, such as a common application at 208 volts, the current to deliver 10 KVA is proportionately higher and there is risk of passing current through the secondary that is higher than its rated current. If so, the unit could be overheated and could be damaged!

In Figure 22D, let's analyze the currents when source voltage is 208 and load is exactly 10 KVA and the load voltage 10 percent higher or 228.8 volts.

$$10 \text{ KVA divided by } 0.2288 = 43.7 \text{ amperes}$$

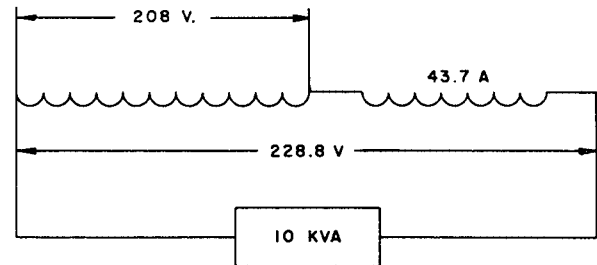

Fig. 22D

But, our secondary design current is 41.7, which means the winding is exposed to 4.8 percent higher than rated current. Because heating varies as the square ( $I^2$ ) of the current our heating rate is 9.83 percent higher than normal.

Do we need to worry about this? Maybe yes, maybe no. The answer would be yes if the source voltage fell even lower than 208 volts because then the current would get higher on a motor load. It is typical of induction and synchronous motors that the current rises at about the same rate as the voltage drops. It would also be yes if the motor would be continuously overloaded.

It would be no if we had a resistance load because then the current drops as the voltage drops. It would also be no if the motor were not fully loaded, a condition that normally exists on most applications. That we are on safe ground is pretty well confirmed by the fact that all or most manufacturers use the same KVA load limit figures as shown in our Bulletin D - 1D.

# Part XXXI

## How Buck And Boost Are Used

In their simplest form, these insulated units will deliver 12 or 24 volts when the primaries are energized at 120 or 240 volts respectively. Their prime use and value, however, lies in the fact that the primaries and secondaries can be interconnected, thus permitting their use as an auto transformer.

Assume a customer has 208 volts service in his place, but happens to have a 230 volt load that must be served. Reference to diagram 2 on Page 13 of Bulletin D - 1D will reveal the connections but what you are interested in is "why does it work."

If you were to picture in your mind that the voltage direction between H1 and H4 at a given instant is to the right, from H1 to H4, and also to the right from X1 to X4, then we are at a good starting point. Because all of these windings are on the same core they are "in phase" with each other! By connecting X1 to H4, the source voltage and the induced voltage in the secondary are in the same direction and add arithmetically. It is shown that only 208 volts exist between H1 and H4 so between X1 and X4 this extra voltage will be equal to 208 divided by 10 or 20.8 volts. From H1 to X4, we get 208 plus 20.8, or a total of 228.8 volts. This is close enough to 230 volts that the load equipment will function properly.

What has been explained above is the "boost" connection. But what if we reversed the secondary so that X4 was connected to H4? This would also reverse the polarity of the secondary with the result that a voltage from H1 to X1 would be 208 minus 20.8, or 187.2 volts. It really isn't complicated if you think in terms of every-day experiences. Assume a father can pull 200 lbs. and his son only 100 lbs. If both of them work together, their combined effort to pull the wagon would be 300 lbs. But if the son went to the other end and pulled in the opposite direction, the net effect would be 200 minus 100, or 100 lbs. in dad's direction. So keep it simple and suddenly the picture will become crystal clear.

# Part XXXII

## Improper Connections

Before this section could be written and understood it was essential that an elementary grasp of three phase vectors described in Part 29 had been acquired by the reader.

The average plant electrician is so accustomed to connecting the midpoint of a 120/240 volt secondary winding to ground that under certain unusual conditions he may unexpectedly cause a problem. Such a problem can arise when a buck and boost transformer receives its single phase energy from a 208/120 volt, three phase transformer which has its neutral grounded. Please refer to Figure 26.

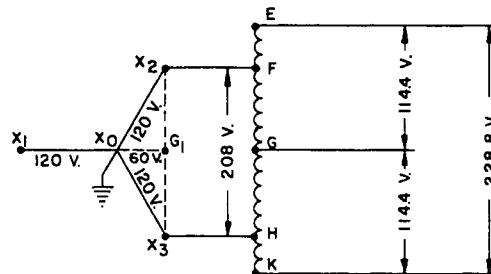

Fig. 26

The circuit with the solid lines is very straightforward as shown. When 208 volt, single phase is applied between F and H of the buck and boost unit, we would get 114.4 volt readings between the midpoint G and either extremity of the winding at E and K. The 114.4 volt figure results from 104 volts on the primary to which 10.4 volts is added. So far so good, but now our electrician gets a bright idea! The transformer on the left may be a couple hundred feet away from the school building where an electric range is to be installed in the new home economics classroom. Almost instinctively he thinks, "why should I run a neutral 200 feet from X<sub>0</sub> on the power transformer all the way to the classroom where the buck and boost unit is located just to get the neutral connection to supply 120 volts to the range switches, the lights, and the exhaust fan?" "I'll just tie G to ground and the job will be done."

That's when the trouble begins! In the diagram, a dotted line has been drawn between X2 and X3 with a mid-point marked  $G_1$  and this line pictorially is the vector position of the voltage between F and H. The letters G and  $G_1$  are really the same point. Notice that  $G_1$  and  $X_0$  are not the same electrical point. Actually they are 60 volts apart so a short circuit is created the instant G (hence  $G_1$ ) is tied to ground in the classroom.

The short circuit current is limited only by the transformer impedance and by the ground resistance from  $X_0$  to  $G_1$ . Let's assume this resistance is very low (due to water pipes, existing conduits, etc.). If it were zero,  $G_1$  would actually be forced to assume the position of  $X_0$  and then some new conditions arise!

Before the ground connection was made FG and GH were energized at 104 volts (1/2 of 208) but after the grounding,  $G_1$  (hence G) is now at  $X_0$ , so, instead of 104 volts between G and F, or G and H, those half windings are now at 120 volts each and this increases the voltage from G to E and G to K, to 129.3 volts! Several things have now happened:

- A. The ground short circuit will tend to overload the windings causing premature failure if the load is equal to the transformer KVA.
- B. The over voltage at the range from phase to neutral will shorten filament lamp life and may overload the exhaust fan, timer and clock motors.
- C. In addition, the over voltages on the buck and boost transformers cause load demands above nameplate ratings inviting early failure.

So much for the wrong way, what is the accepted solution? To run a neutral wire from the power transformer to the point of load and use it as a neutral connection to the range and the ground. There must be no connection of point G either to ground or the range neutral.

Even this is not a perfect solution for we will still reach 129.3 volts on lamps, and motors. However this connection is recommended by a number of transformer manufacturers and has approval of most local electrical codes. The vector diagram for the connections is described in Figure 26A.

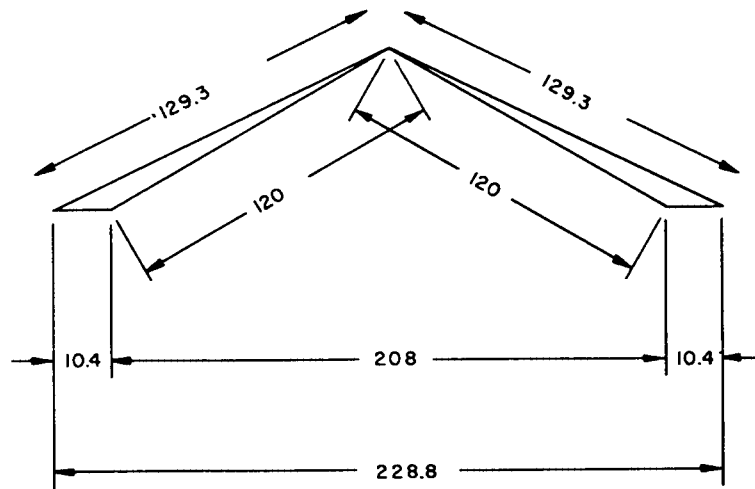

Fig. 26A

## Part XXXIII

### Insulation Life And Temperature

In Lesson 2, Part 8, we merely mentioned the difference between a conductor and an insulator. We will now endeavor to provide a better understanding of how insulation is affected by temperature. As supplementary reading it is urged that you digest the information in Bulletin D - 1C that appears on Pages 1, 2, and 3.

## Part XXXIV

### Average Conductor Rise vs Hot Spot

Just as it would be difficult for the owner of an automobile to measure the temperature within one of the cylinders of his engine, similarly it is impossible to determine the hottest spot in a transformer under various conditions of loading unless you had very specialized equipment. In our automobile, the water temperature gauge or the temperature warning light informs us that we are operating within or beyond safe limits.

Through years of experience transformer design engineers have determined quite accurately where the hottest spot will be in a transformer, and what temperatures we can expect for different loads. Because we do not have thermocouples to help measure the "hot spot," the engineers have found a way to determine the temperature, without getting into the very heart of the coil winding. This method is known as average conductor temperature rise. Thus, water temperature in a car, and average conductor temperature in a transformer alert us whether we are operating in safe zones, or inviting early failure of our investment.

## Part XXXV

### Average Conductor Rise

It is the nature of metallic conductors such as copper or aluminum, to change their resistance as the temperature of the conductor changes. Thus, if the resistance of a transformer winding were measured at room temperature at no load, and again several hours after it was fully loaded, two different readings would result and these could be related thereafter to the average coil temperature.

Because the conductors are surrounded by insulation it is evident that the insulation is exposed to the same temperature. If average conductor rise is the indicator that serves as a warning of impending trouble, then how do we know what the temperature is at the "hottest spot," where it is known, from experience, fatal insulation damage can occur? The engineers have an answer to that known as "temperature gradient," This gradient is the difference between the average conductor and the hot spot temperature. These values are shown in Table 1.

TABLE 1

Type	(150°C Rise by Resistance)	(115°C Rise by Resistance)	(80°C Rise by Resistance)
Rise by Resistance	150	115	80
Hot Spot Allowance	30	30	30
Ambient Allowance	<u>40</u>	<u>40</u>	<u>40</u>
Ultimate Temperature of Winding	220°C	185°C	150°C

## Part XXXVI

### Ambient To Ultimate Temperature

The ultimate temperature specifies the maximum temperature beyond which the three classes should never be operated. Later on, we'll explain why we shouldn't even approach these limits. Let's look at Class H. If the ambient air temperature around a transformer is 40 degrees Centigrade (104 degrees F) and we add to that the allowable rise of 150 degrees Centigrade, we arrive at an actual average copper temperature of 190 degrees C. The engineers have alerted us that the hot spot gradient is 30 degrees C, therefore, the maximum permissible temperature is 220.

It becomes apparent if the transformer were outdoors in the winter and the ambient temperature was only 0 degrees C (32 degrees F), that the 220 degrees C figure also would be reduced by 40 degrees, hence, the hot spot would only be 180 degrees C. This explains why transformers can be more heavily loaded as the ambient temperature is reduced.



## Part XXXVII Insulation "Half Life"

"Half-life" is a new word in our vocabulary and relates to the fact that for every 8 to 10 degree C increase in insulation temperature, its useful life will be cut in two. The original rule of thumb was 8 degrees but in recent years technical writings generally refer to 10 degrees.

## Part XXXVIII 20,000 Hours

It takes a bit of digging in technical treatises to uncover that 20,000 hours is the best estimate of the half-life of insulation that has been exposed to maximum permissible temperature from the time it was brand spanking new! This turns out to be only 2.3 years!

At "Half-Life" insulation is more brittle, some of its other original qualities such as foldability, puncture strength, etc., have gradually degraded with the general consensus that thereafter it is vulnerable to failure! Your author is personally aware of experiences wherein transformers had given trouble free service for 25 years. Because of load growth they were changed for larger units and relocated, and a short time later, for no apparent reason, they would fail. The vibration of moving, and reduced insulation strength made them vulnerable to failure.

If transformer insulation is vulnerable to failure in slightly over two years, why has the reputation and performance of Square D transformers been so good?

Simply because knowing these facts, our design engineers built a factor of safety into our products to provide a realistic life span.

For example, assume we were invited to bid on transformers to serve the load in a glass factory where we know the load of 500 KVA will be on 24 hours per day, 365 days per year. Thus the transformer receives no benefit of valleys in the load curve where it could operate much cooler. Let's look at Table 2 to understand the logic.

**TABLE 2. RELATIVE LIFE USING  
A 220°C. INSULATION SYSTEM**

Design average conductor temperature rise	Equivalent hot-spot temperature	Minimum theoretical life (years)
150C	220C	2.3
140C	210C	4.6
130C	200C	9.2
120C	190C	18.4
110C	180C	36.8
100C	170C	73.6
90C	160C	147.2
80C	150C	294.4

Assume we wanted a minimum life expectancy of 25 years. This can be estimated in the right hand column about half way between 18.4 and 36.8 years. In the left column this would inform us that average conductor temperature rise should be about 115 degrees C.

# Part XXXIX

## Extending Life

To achieve 115 degrees C Rise two factors can help. Reduce the losses in the coil which cause the heating and provide more liberal air ducts to improve cooling. This requires a larger conductor, thus lower resistance and lower watts loss and also increases physical coil size. The price to achieve this is higher material and production cost, which is in the range of 10% above a standard 150 degree C Rise Unit.

THESE ARE SOME OF THE ADVANTAGES:

1. First and foremost a greater life expectancy is obtained without threat of plant down time!
2. Throughout the lifetime of the installation, the transformer actually costs nothing! Does this sound like an incredible statement? Then, read on! Within six years, the user gets back all of his premium including interest, and in an additional 17 years, saves enough dollars through reduced conductor losses to buy another transformer without raising a single cent of new capital! This whole story is presented in detail in our *Watchdog* Transformer Bulletin D - 1C.
3. We know of a case where a glass plant transformer failed in about three years, much to the disgust of the customer and the chagrin of the supplier.
4. Transformers not exposed to the rugged duty described above may get by for a reasonable number of years if the load cycle provides adequate cooling off time, or are oversized for the true load demand. This would be typical of pad mounted transformers for residential service where during the night the units are almost always coasting along with minimum heating. Furthermore, during the early years of a new residential plot development, the transformers may be very lightly loaded. It should be stated at this point that what has been explained applies equally to dry - type or liquid filled units.

# Part XL

## Auto Transformers For 208Y/120 Volt Service

Many buildings and plants are presently served at 480Y/277 volts for their main distribution system. However, such structures also require 208Y/120 for convenience outlets, small power tools, kitchen loads and computer installations. The historic way to serve these is by small step - down transformers of the insulating type such as our type SO, three phase lighting and power transformer shown on Page 4 of Bulletin D - 1D.

The circuitry would be as shown in Figure 27. To conserve diagram space, only the secondary winding of the large power transformer serving the plant is shown. Between it and the two sets of windings at the right, is a representation of the plant bus system to which numerous installations such as our Type SO insulating transformer could be connected. In this figure we show only one. The delta primary served at 480 volts is transformed to a wye connected secondary from which 120 volts convenience outlets can be connected from X<sub>1</sub>, X<sub>2</sub>, or X<sub>3</sub>, to X<sub>0</sub>.

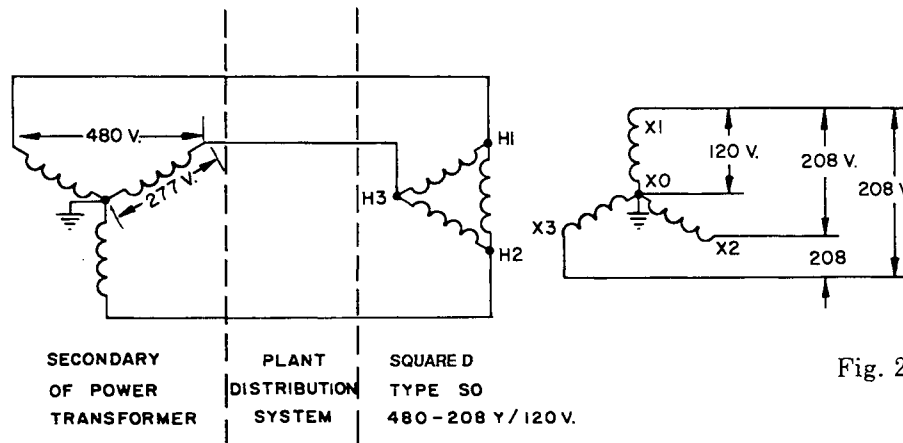

Fig. 27

The purpose of this lesson is to show another method of achieving the same results at a somewhat lower cost by utilizing Square D ATQ auto transformers. Every now and then a consulting engineer and/or a user publishes an article pointing out the economic advantages which they recommend should be adopted by more plant and building superintendents.

In Figure 28, it can be seen that the only change from Figure 27 is in the right hand position of the diagram. Note that instead of a delta-ye insulating transformer, you now observe a diagram that should remind you of the

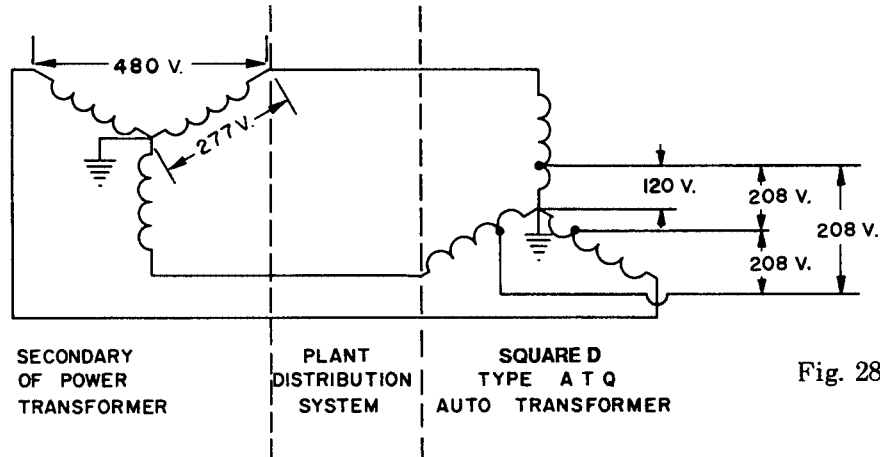

Fig. 28

discussion relating to Part 29, and to Figure 22C and 22D in Part 30 when we were studying Buck and Boost principles. The principles are identical except in this instance we are analyzing three phase applications.

To help tune the reader to the same wavelength, let us look at just one part of the three phase analysis using actual values that would exist if we were using one of three single phase auto transformers. Figures 29A and 29B should be helpful.

In Figure 29A, we have a conventional 50 KVA insulating transformer designed with a 277 volt primary and a 120 volt secondary. If we divide 50,000 volt amperes (50KVA) by 277 volts, we can calculate the primary current as 180 amperes. Assume the load is 50 KVA. On the secondary side the current would be 50,000 divided by 120 = 416.0 amperes. (Note that we have ignored transformer losses for simplification).

With the primary voltage from X to Z equal to 277 volts, it should be obvious that at some point Y, a voltmeter could read 120 volts from Y to Z. This would leave 157 volts from X to Y. Between Y<sub>1</sub> and Z<sub>1</sub>, we also know the design potential is 120 volts so there should be no harm in connecting Y to Y<sub>1</sub>, and Z to Z<sub>1</sub>. If we do this, then we have the equivalent circuit as shown in Figure 29B.

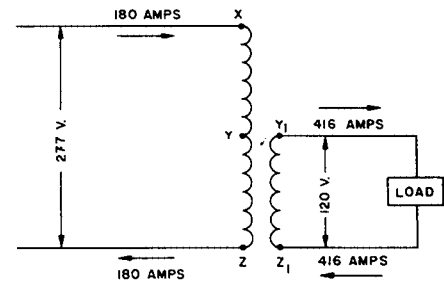

Fig. 29A

This is exactly what is achieved in an auto transformer so let's evaluate if this brings any benefits.

Because the load is still 50,000 volt amperes, the secondary current in Figure 29B will remain at 416 amperes. Similarly, the primary must supply 50 KVA, hence the primary lines continue to feed in 180 amperes. Notice, however, that a change has taken place in the winding between Y and Z! It can be seen that 416 amperes flow in the secondary wire to the left toward Z, but only 180 amperes flow away from Z toward the 277 volt source! This is a difference of 236 amperes. Since it is impossible to store amperes anywhere, then all current arriving at a point such as Z must leave that point. The only place it can flow is upward from Z to Y.

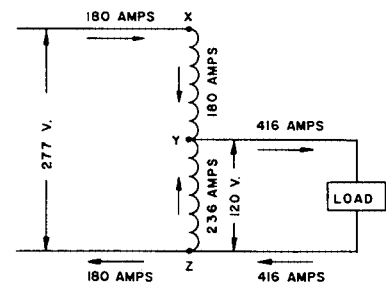

Fig. 29B

Let's see if we have "lost" any amperes at Y. With 236 coming up from Z and 180 going down from X, the sum of these at Y must move to the right as 416 amperes of secondary current; so again, everything balances out.

In Figure 29A the secondary winding has to be rugged enough to carry 416 amperes, but in 29B that winding could be made of smaller wire because the current now is only 236 amperes. This reduces the cost of copper, size of coil and weight. A further saving in weight appears in the smaller core that is required to serve this new electrical configuration. This also reduces exciting current.

By picturing the substitution of Figure 28, it is now more readily understood how the three phase combination works.

Strangely enough, this concept has not been used extensively in the industry. The net result from a production standpoint is that the volume is low which tends to increase production costs.

With better understanding of the ATQ family of transformers you are better equipped to discuss their use with customers. Should customers raise questions pertaining to their use, that is, beyond the scope of this lesson, direct the information to headquarters for a specific response. Basically speaking, auto transformers are attractive from the viewpoint of cost, physical size, efficiency, sound level, regulation and exciting current. On occasions you may have a customer comment that he has heard of problems involving telephone interference and abnormal voltages where unusual grounding of delta source voltages exist. Volumes can be written about abnormal conditions, but just as abnormal implies, they are the unusual and not the normal expectation. When in doubt, ask us . . . .

## Brief Digest Of Potential Problems

It is human nature among many users that if any problems may develop there is hesitancy to "take a chance." Thus, opportunities for savings are overlooked, volume does not reach levels that create production economies and salesmen also being human, take the path of least resistance and continue to sell higher cost insulating types.

Occasionally, a manufacturer will promote the auto transformer concept and create a flurry of interest in the market place. It was for this potentiality that this section was prepared to give you a little better understanding should a question be raised among your customers.

Because problems have arisen in certain areas with concern for safety of personnel and apparatus as well as telephone interference, a word of caution suggests that local regulations should be checked to see if auto transformer use is prohibited.

Some of you may recall in Figure 26 (Part 32) that when energizing a buck and boost transformer from a three phase wye source it is possible to create a short circuit between the grounded wye source neutral and the mid-point of the buck and boost winding.

With the auto transformers discussed in this section, a similar condition can develop. In some locations, (Chicago is an example) the corner of a delta, or a mid-point of a phase of the delta may be grounded. Let's assume a corner of the delta source is grounded and from this source we planned to energize a wye connected three phase auto transformer with its neutral grounded. It is obvious that if the middle of the wye secondary and one of the source leads are both grounded, a short circuit will be established between the two points. Hopefully, protective devices will operate to clear the fault.

If the neutral of the auto transformer were not grounded and one corner of the delta supply was, then the other two supply lines would have a potential to ground equal to phase voltage while the neutral would be free to float at varying smaller potentials depending on the load balance between phases.

We also mentioned good regulation. If the auto transformer is rated 480 to 208 it will have approximately 56.7% of the two winding impedance, hence good regulation. This also permits greater fault currents to flow (in inverse ratio, hence 1.732 times). Since the forces tending to tear the coils apart vary as the square of the current, these forces are three times as great (1.732 times 1.732) as in the two winding transformer.

Potential telephone and computer interference will not be discussed here, as it is not common in a plant distribution system.

Finally, the price benefits for auto transformers do not begin to become significant until the size exceeds 75 KVA and the voltage ratio is less than 2:1.

## Part XLI

### Co-Ratio

In your customer relations while discussing auto transformers some engineers may toss out the term “co-ratio.” It has to do with the facts in the preceding paragraphs. It is not difficult to understand, so let’s put it into our vocabulary to help enhance our image in the customer’s mind. It is a mathematical expression that has to do with the source and the load voltage. So let’s look at the expression and learn what it can tell us!

$$\text{Co-Ratio} = \frac{\text{HV} - \text{LV}}{\text{HV}}$$

This can be written as:

$$\text{Co-Ratio} = \frac{\text{HV}}{\text{HV}} - \frac{\text{LV}}{\text{HV}}$$

Since  $\frac{\text{HV}}{\text{HV}}$  equals 1, we can substitute the one and rewrite

the expression as:

$$\text{Co-Ratio} = 1 - \frac{\text{LV}}{\text{HV}}$$

The insulating transformer in Figure 29A has a primary winding that is rated  $180 \times 277 = 50000$  va or 50 KVA. Similarly, the secondary winding rating is  $416 \times 120 = 50$  KVA. Therefore, the transformer is known as a 50 KVA unit.

In the auto transformer in 29B, we do not have primary and secondary windings, rather we have a “series” and a “common” winding. The co-ratio of the transformer is  $1 - \frac{120}{277} = 1 - .433 = .567$ . This number actually tells us the relative KVA size of 29B versus 29A. Let’s prove it!

The KVA rating of the common winding is  $236 \times 120 = 28326$  or slightly over 28 KVA. The series winding which has 157 volts impressed across it ( $277 - 120$ ) has a rating of 180 times 157 equals 28260 or slightly over 28 KVA. (If we had not dropped the fractional amperes when we first discussed these circuits, the KVA values would have been exactly the same). Since the KVA rating of this transformer is the sum of the KVA of each winding divided by the number of windings we would have

$$\frac{28 + 28}{2} = 28 \text{ KVA}$$

If we were to divide the effective KVA rating of the auto by the insulating unit, we would have

$$\frac{28}{50} = .560$$

If we had not rounded the amperes to the nearest whole number the answer would have been exactly the same as the co-ratio calculated previously or .567. Thus, by simply calculating the co-ratio of the auto transformer you have an accurate ratio of the KVA ratings and a fair clue as to the weight and relative size of the two units that can serve an identical load.

## A Cost Clue?

It would be great if the co-ratio could make you a “quoting genius” in the field, but such is not the case. For example, in the smaller ratings even though the core and coil is smaller, the terminals and leads must carry the same current as in an insulating unit, the core assembly labor and cabinet cost doesn't change much, so there is not too great a difference in price until we get up to about 300 KVA. In the case of a 500 KVA in the voltage rating, the auto cost is about 68 to 70% of the insulating price, whereas the co-ratio is .567 or 56.7%. If we added 10 to 12% to the co-ratio, we would have reached 68%, the number previously mentioned as the difference in cost.

## Other Considerations

Because an auto transformer may be served by a 480Y/277 source, we have a wye - wye interconnection. Square D Communicator SC - 6 described a problem that can occur when wye - wye banks are used. It is recommended that SC - 6 be supplementary reading to this presentation.

In long rural distribution lines, third harmonic currents can flow in the neutral and may cause telephone interference. This may be one reason why in some areas local codes place certain restrictions on auto transformer applications. This is not a problem in plant installations.

Because there is a metallic connection between the source and the secondary, any abnormal high voltage could be carried back to the secondary circuit more readily than in an insulating transformer. The problem is guarded against by grounding the neutral of the auto transformer. A primary line fault on such a system merely causes collapsed voltage on one phase. The customary protective devices used clear the involved phase.

Inherently, an auto transformer has a lower impedance than its equivalent rated insulating unit. Thus a short circuit at or near the secondary terminals imposes greater stresses on the winding. However, the transformer designer knows of this and builds his unit accordingly. It is interesting also to know that our new found phrase “co-ratio” is related to these forces. The short circuit current increases inversely as the co-ratio, which means that the smaller the co-ratio, the higher the fault currents can be! For example, in a 14,400 to 7200 volts unit (co-ratio = .5), the fault current will be twice as great as in an insulating unit and the telescoping forces will increase as the square of the current or four times as great.

## Part XLII

### Tee-Connected Transformers

In Part 26, we touched a few fundamentals to better understand the meaning of taps and how they were indicated in wiring diagrams.

On Pages 4, 5, and 7 of Bulletin D-1D, some of our three phase units are listed. They all are identified as requiring a delta primary. While all of them are supplied or energized by a delta primary some of the smaller ratings on these pages are not wound with delta primaries. All units 15 KVA and smaller, the secondaries of which are rated 208Y/120, or 480Y/277, are listed in the wiring diagram column with connections as in Diagrams 8 or 9 on page 11. Note also that the three phase type F, 3 thru 15 KVA, shown on Page 10 also use the No. 8 diagram and hence are related to the analysis that follows. These transformers are Tee connected!

### Why Tee Connected?

When a delta wye transformer is built we would usually expect to find three primary and three secondary coils. It is a well known experience in the entire transformer industry that as the size of the transformer is reduced, the cost per KVA to produce it goes up. Therefore, in the cost critical smaller sizes, anything that can be done to reduce production costs, without sacrificing performance, should be investigated. Fortunately, the Tee connected unit is a solution and through its use, not only the manufacturer but also the user benefits in reduced cost.

The Tee connected unit requires only two primary and two secondary windings thus creating savings.

# How It Works

To the uninitiated, the typical wiring diagrams on nameplates and in catalogs are not as easily interpreted as when they are redrawn to simulate the phase relationship that actually exists between the coils. Let us refer to Figure 30A. The connections are exactly the same as shown on Page 10 of our Bulletin D - 1D. All we have done is to rearrange the windings so that they show the phase relationship that actually exists. To simplify the diagram, we have eliminated the taps.

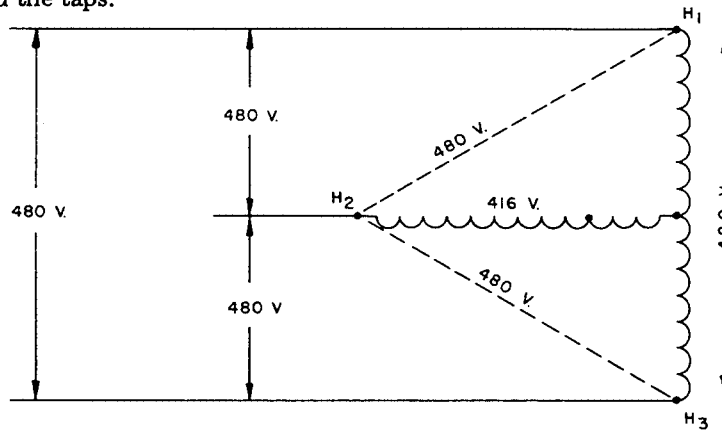

Fig. 30A

rearrange the windings so that they show the phase relationship that actually exists. To simplify the diagram, we have eliminated the taps.

If you were to draw an equilateral triangle as  $H_1$ ,  $H_2$ , and  $H_3$  so that the  $H_1$  to  $H_3$  distance was 4.8 inches long, you would find that the distance from  $H_2$  to the midpoint of  $H_1 H_3$  measures 4.16 inches. The experienced engineer doesn't need to draw a diagram to scale because he knows this value is  $480 \text{ volts} \times .866 = 415.68 \text{ volts}$ . Also, if you were to place an imaginary dot exactly in the center of this triangle it would lay on the horizontal winding we have drawn. If you measured the distance from it to  $H_2$ , you would find it to be twice as long as the distance between the dot and the midpoint of  $H_1$  to  $H_3$ . The measured distances would be 2.77 inches and 1.385 inches or the equivalent of 277 volts and  $138\frac{1}{2}$  volts.

Now, let's look at the secondary winding enclosed by  $X_1$ ,  $X_2$ , and  $X_3$ . The relationship is identical to that just described.

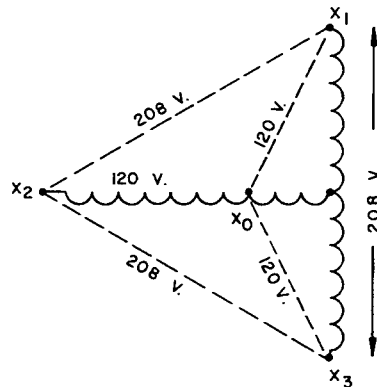

Fig. 30B

By placing the neutral tap  $X_0$  so that one third of the number of turns exist between it and the midpoint of  $X_1$  and  $X_3$ , as exist between it and  $X_2$ , we then can establish  $X_0$  as a neutral point which may be grounded. This provides 120 volts between  $X_0$  and any of the three secondary terminals and the three phase voltage between  $X_1$ ,  $X_2$ , and  $X_3$ , will be 208 volts.

# Part XLIII

## Three-Phase Core-Type Transformer Connections

In part XVIII we discussed briefly the difference between core type and shell type transformers. Because most Square D transformers are of core type construction we should look at different types of connections and some of the problems which could arise with this type of core. All of the discussion is true for oil-filled and gas-filled units as well as dry-type.

Here are the ways in which three-phase windings can be connected:

Primary Winding

- Delta
- Delta
- Wye
- Wye

Secondary Winding

- Delta
- Wye (or Star)
- Delta
- Wye

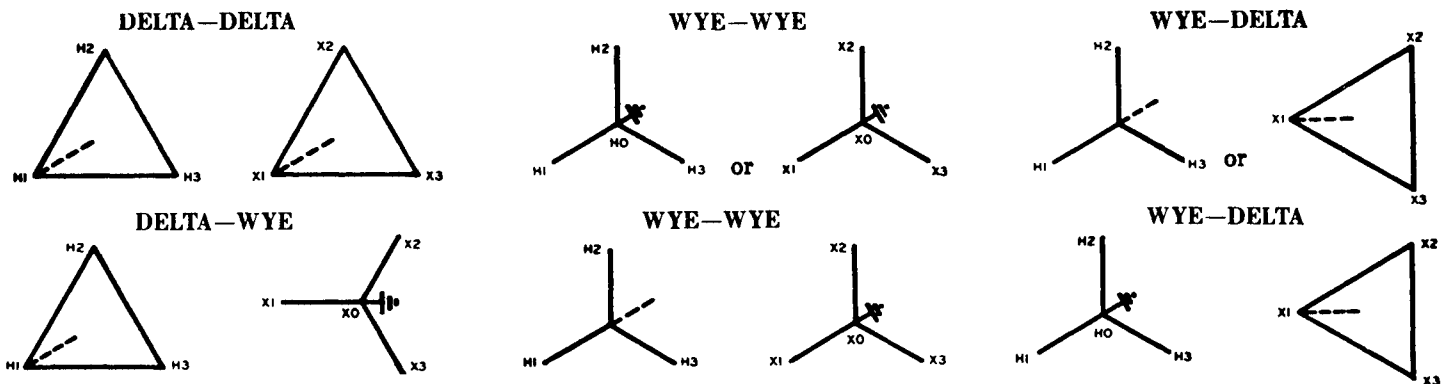

Fig. 31

From our previous discussions, we can see that all of these connections are self-explanatory and none of the combinations present any real hazards, except the last two — the wye primary. Let's see if we can discover why.

In a three phase transformer, all three primary coils produce flux, and the flux from each coil is distributed through all three of the core legs. As we learned earlier, the secondary coils under load also produce flux, distributed through the same core legs in the same manner, and this flux is in opposition to the primary flux, tending to cancel it out. In a properly designed transformer, essentially all of the flux travels through the core, in just the right amount to produce the needed magnetic induction.

Let's assume we have a three phase transformer with a wye connected primary, and a grounded neutral. The secondary can be connected either delta or wye — it makes no difference.

Now let's suppose that a wind storm blew down a wire which was feeding one of the primary coils. The grounded neutral will allow three phase flux to be produced, even though one of the primary coils is open. Obviously, the open primary produces no flux, but its secondary is still connected to the load and will be carrying a current. This secondary current produces a secondary flux, usually an excessive amount. Since there is no opposing flux (remember the primary is open), this flux will quickly fill up the core — we call it saturation — and any excess will take the path of least resistance to complete the magnetic circuit. Because large transformers are made with structural steel bases, angles and enclosure panels, they become an ideal path for the leakage flux. They can become very hot, enough to blister the paint or even cause fire, not to mention the obvious damage to a very expensive transformer. For this reason, wye primaries with grounded neutrals are definitely not recommended unless some means is provided to disconnect all three phases in case of a fault or open circuit in the primary circuit.



# Part XLIV

## Design sound levels vs maximum or guaranteed sound levels

A *design* sound level is the average value of a group of identically manufactured transformers, allowing a plus or minus tolerance from the theoretical design value.

A *maximum* or *guaranteed* sound level permits only a minus tolerance lower than the stated value. Any transformers which exceed this value, when factory tested under prescribed NEMA conditions, are rejected.

## STOCK TRANSFORMER SOUND LEVELS

KVA	Design Sound Level	Guaranteed Sound Level	NEMA Standard Sound Levels
0-9	40	40	40
10-50	42	45	45
51-150	45	50	50
151-300	49	55	55
301-500	53	60	60

## Full load current charts

### FULL LOAD CURRENTS IN AMPERES SINGLE PHASE DRY-TYPE TRANSFORMERS

#### FORMULA

$$\text{Single Phase KVA} = \frac{\text{Volts} \times \text{Load Amperes}}{1000}$$

KVA Rating	RATED LINE VOLTAGE									
	120	240	277	480	600	2400	4160	7200	7620	13200
.25	2.08	1.04	.9	0.52	0.42					
.5	4.16	2.08	1.8	1.04	0.84	0.21	0.12			
.75	6.24	3.12	2.7	1.56	1.2	0.3	0.18			
1.0	8.33	4.16	3.6	2.08	1.6	0.4	0.24			
1.5	12.5	6.24	5.4	3.12	2.4	0.6	0.36	.21	.20	.114
2.0	16.66	8.33	7.2	4.16	3.2	0.8	0.48	.28	.26	.151
3.0	25	12.5	10.8	6.1	4.8	1.2	0.72	.42	.39	.23
5.0	41	21	18	10.4	8.3	2.0	1.2	.70	.66	.38
7.5	62	31	27	15.6	12.5	3.1	1.8	1.04	.98	.57
10.0	83	42	36	21	16.5	4.1	2.4	1.39	1.31	.76
15.0	124	62	54	31	25	6.2	3.6	2.10	1.97	1.14
20.0	166	83	72	42	33	8.2	4.8	2.78	2.62	1.5
25.0	208	104	90	52	42	10.4	6	3.48	3.28	1.9
30.0	249	125	108	62	50	12.5	7	4.18	3.94	2.3
37.5	312	156	135	78	62	15.6	9	5.2	4.92	2.8
50	416	208	180	104	84	21	12	6.9	6.56	3.8
75	624	312	270	156	124	31	18	10.4	9.85	5.6
100	830	415	360	207	168	42	24	13.9	13.1	7.5
125	1040	520	450	260	208	52	30	17.3	16.4	9.5
150	1248	624	540	312	248	62	36	20.8	19.7	11.8
167	1390	695	601	348	278	70	40	23.2	21.9	12.6
200	1660	833	720	416	336	84	48	27.8	26.2	15.0
250	2080	1040	900	520	420	105	60	34.8	32.8	19
333	2760	1390	1199	695	555	139	80	46.0	43.6	25
400	3320	1660	1440	830	672	168	96	55.6	52.5	30
500	4160	2080	1800	1040	840	210	120	69.5	65.5	38
600	5000	2500	2160	1250	1000	250	144	83.6	78.7	45
750	6240	3120	2700	1560	1240	310	180	104	98.5	57
1000	8300	4150	3600	2075	1680	420	240	139	131	76
1500	12480	6240	5400	3120	2480	620	360	208	197	113
2000	16600	8300	7200	4150	3360	840	480	278	262	152

### FULL LOAD CURRENTS IN AMPERES THREE PHASE DRY-TYPE TRANSFORMERS

#### FORMULA

$$\text{Three Phase KVA} = \frac{\text{Volts} \times \text{Load Amperes} \times 1.73}{1000}$$

KVA Rating	RATED LINE VOLTAGE										
	120	208	240	480	600	2400	4160	7200	7620	12470	13200
6	28.8	16.6	14.4	7.2	5.8	1.4	.83	.48	.45	.28	.26
9	43.2	25.0	21.6	10.8	8.7	2.2	1.2	.72	.68	.42	.39
10	48.0	27.7	24	12	9.6	2.4	1.4	.8	.76	.46	.44
15	72.0	41.6	36	18	14.4	3.6	2.08	1.2	1.1	.69	.65
20	96	55.5	48	24	19.0	4.8	2.8	1.6	1.5	.92	.9
25	120	69.5	60	30	24.0	6.0	3.5	2.0	1.9	1.16	1.1
30	144	83.0	72	36	28.8	7.2	4.2	2.4	2.3	1.39	1.3
37.5	180	104	90	45	36	9.0	5.2	3.0	2.8	1.74	1.6
45	216	125	108	54	43	10.8	6.2	3.6	3.4	2.08	2.0
50	240	138	120	60	48	12	7.0	4	3.8	2.3	2.2
75	360	208	180	90	72	18	10.4	6	5.7	3.5	3.3
100	480	278	240	120	96	24	14.0	8	7.6	4.6	4.3
112.5	540	312	270	135	108	27	15.6	9	8.5	5.2	4.9
150	720	415	360	180	144	36	21.0	12	11.4	6.9	6.6
200	960	554	480	240	192	48	28.0	16	15.2	9.2	8.6
225	1080	625	540	270	216	54	31.2	18	17.1	10.4	9.8
250	1200	695	600	300	240	60	35.0	20	18.9	11.6	10.8
300	1440	830	720	360	288	72	42.0	24	22.8	13.9	13.2
400	1920	1110	960	480	384	96	55.6	32	30.4	18.5	17.5
500	2400	1380	1200	600	480	120	70	40	38	23.1	22.0
600	2880	1660	1440	720	576	144	84	48	45.6	27.7	26.2
750	3600	2080	1800	900	720	180	104	60	57	34.7	33
1000	4800	2780	2400	1200	960	240	140	80	76	46.2	44
1500	7200	4150	3600	1800	1440	360	208	120	114	69.4	66
2000	9600	5540	4800	2400	1920	480	278	160	151	92.4	87



**SALES OFFICES IN THE  
UNITED STATES**

**ALABAMA**

Birmingham (205) 870-5591  
Dothan (205) 793-2177  
Huntsville (205) 539-2465  
Mobile (205) 342-7747  
Montgomery (205) 271-0230

**ALASKA**

Anchorage (907) 278-6048

**ARIZONA**

Phoenix (602) 279-4901  
Tucson (602) 795-3600

**ARKANSAS**

Ft. Smith (501) 452-7312  
Little Rock (501) 225-3648

**CALIFORNIA**

Bakersfield (805) 833-1985  
Fresno (209) 268-6268  
Hayward (San Francisco) (415) 887-1181  
Long Beach (213) 428-7553  
North Hollywood (Los Angeles) (818) 508-0592  
Orange (714) 532-4861  
Riverside (714) 687-1262  
Sacramento (916) 381-5056  
San Diego (619) 569-8953  
Stockton (209) 944-5633  
Ventura (805) 658-2566

**COLORADO**

Colorado Springs (719) 574-0061  
Englewood (Denver) (303) 799-9003

**CONNECTICUT**

Wethersfield (Hartford) (203) 529-7472

**DISTRICT OF COLUMBIA**

Rockville (Wash. D.C.) (301) 424-9510  
424-1442

**FLORIDA**

Ft. Myers (813) 936-5573  
Jacksonville (904) 744-7881  
Orlando (407) 774-5151  
Pembroke Pines (Miami) (305) 435-4400  
Sarasota (813) 957-0950  
Tallahassee (904) 878-7895  
Tampa (813) 289-0227  
West Palm Beach (407) 626-8788

**GEORGIA**

Atlanta (404) 432-4421  
Columbus (Muscogee) (404) 561-7825  
Macon (912) 745-2382  
Savannah (912) 356-9546

**HAWAII**

Honolulu (808) 487-5530

**IDAHO**

Boise (208) 376-0552  
Pocatello (208) 234-0366

**ILLINOIS**

Champaign (217) 356-0211  
Lombard (Chicago) (312) 916-9550  
Peoria (309) 673-0508  
Rockford (815) 965-2060  
Springfield (Sangamon) (217) 546-1477

**INDIANA**

Evansville (812) 424-9999  
Fort Wayne (219) 483-3194  
Highland (Hammond) (219) 972-9600  
(312) 721-6031  
Indianapolis (317) 255-0664  
Mishawaka (So. Bend) (219) 259-8521

**IOWA**

Cedar Rapids (319) 366-0736  
Davenport (319) 324-0876  
Des Moines (515) 224-9918

**KANSAS**

Shawnee (Kansas City) (913) 631-1000  
Wichita (316) 264-9338

**KENTUCKY**

Lexington (606) 278-0308  
Louisville (502) 425-8363  
Paducah (502) 554-5515

**LOUISIANA**

Baton Rouge (504) 926-7279  
Harahan (New Orleans) (504) 733-0964  
Lafayette (318) 988-1560  
Monroe (318) 322-2188  
Shreveport (318) 865-4267

**MAINE**

Portland (207) 774-1409

**MARYLAND**

Hagerstown (301) 739-5760  
Lutherville (Baltimore) (301) 337-8448  
Salisbury (301) 749-2544

**MASSACHUSETTS**

Braintree (Boston) (617) 848-1110

**MICHIGAN**

Grand Blanc (Flint) (313) 694-5101  
Grand Rapids (616) 459-3529  
Kalamazoo (616) 342-2117  
Lansing (517) 337-2835  
Portage (Kalamazoo) (616) 342-2117  
Saginaw (517) 792-1553  
Traverse City (616) 946-3773  
Troy (Detroit) (313) 583-6100

**MINNESOTA**

Duluth (218) 723-1010  
Plymouth (612) 476-6909  
(Minneapolis) (612) 476-6909  
Rochester (507) 285-1700

**MISSISSIPPI**

Hattiesburg (601) 583-4743  
Jackson (601) 982-1031  
Tupelo (601) 842-3398

**MISSOURI**

Jefferson City (314) 893-4426  
Springfield (417) 887-2307  
St. Louis (314) 849-6330

**MONTANA**

Billings (406) 248-1203

**NEBRASKA**

Omaha (402) 330-3753

**NEVADA**

Las Vegas (702) 878-3370

**NEW HAMPSHIRE**

Bedford (Manchester) (603) 668-1204

**NEW JERSEY**

Bellmawr (So. Jersey) (609) 933-1800  
Pine Brook (New Jersey) (201) 575-7000

**NEW MEXICO**

Albuquerque (505) 828-1018

**NEW YORK**

Binghamton (607) 723-7337  
Buffalo (716) 836-5800  
DeWitt (Syracuse) (315) 455-5324  
Mineola (New York City) (718) 895-3150  
Rensselaer (Albany) (518) 449-1322  
Rochester (716) 424-4171  
White Plains (914) 428-7790

**NORTH CAROLINA**

Asheville (704) 255-1325  
Charlotte (704) 376-1387  
Greensboro (919) 292-8995  
Greenville (919) 756-2117  
Raleigh (919) 782-1338  
Wrightsville Beach (Wilmington) (919) 256-9956

**NORTH DAKOTA**

Fargo (701) 235-7223

**OHIO**

Akron (216) 836-5593  
Cincinnati (513) 793-6811  
Columbus (614) 486-4329  
Dayton (513) 433-7771  
Lima (419) 224-0719  
Maple Hts. (Cleveland) (216) 581-3400  
Toledo (419) 535-1293  
Youngstown (216) 782-2295

**OKLAHOMA**

Oklahoma City (405) 942-7334  
Tulsa (918) 250-3516

**OREGON**

Eugene (503) 343-2591  
Tigard (Portland) (503) 684-1090

**PENNSYLVANIA**

Allentown (215) 694-9600  
Altoona (814) 942-1966  
Camp Hill (Harrisburg) (717) 761-4650  
Erie (814) 833-8414  
Media (Philadelphia) (215) 565-8750  
Pittsburgh (412) 343-7500  
Wilkes-Barre (717) 825-4569  
York (717) 757-9421

**RHODE ISLAND**

Cranston (Providence) (401) 943-3380

**SOUTH CAROLINA**

Charleston (803) 556-0773  
Columbia (803) 772-3553  
Greenville (803) 288-6384

**SOUTH DAKOTA**

Sioux Falls (605) 334-2151

**TENNESSEE**

Chattanooga (615) 877-1381  
Kingsport (615) 239-7948  
Knoxville (615) 524-7477  
Memphis (901) 682-8866  
Nashville (615) 371-8069

**TEXAS**

Abilene (915) 672-5022  
Amarillo (806) 372-1938  
Austin (512) 346-7120  
Beaumont (409) 866-7726  
Corpus Christi (512) 883-5566  
Dallas (214) 637-1491  
El Paso (915) 592-8813  
Fort Worth (817) 831-4579  
Harlingen (512) 423-1694  
Houston (713) 827-1300  
(Northeast Houston) (409) 265-3733  
(Southeast Houston) (713) 480-1039  
Longview (214) 753-5775  
Lubbock (806) 762-5736  
Midland (915) 694-8430  
San Antonio (512) 349-0197  
Sherman (214) 868-2720  
Waco (817) 776-3432  
Wichita Falls (817) 322-5589

**UTAH**

Salt Lake City (801) 486-8447

**VIRGINIA**

Charlottesville (804) 973-7069  
Norfolk (804) 461-1290  
Richmond (804) 285-7508  
Roanoke (703) 344-7707

**WASHINGTON**

Mercer Island (Seattle) (206) 232-9702  
Spokane (509) 535-3685  
Tacoma (206) 565-7730

**WEST VIRGINIA**

Barboursville (Huntington) (304) 736-8944

**WISCONSIN**

Green Bay (414) 494-3313  
Madison (608) 231-2244  
Milwaukee (414) 359-0959  
Racine (414) 554-7711

**WYOMING**

Casper (307) 234-1017



**SQUARE D COMPANY**

*Dedicated to Growth • Committed to Quality*

Transformer Division  
PO Box 5002  
Monroe, NC 28110-9954  
(704) 283-7411  
FAX: (704) 283-2807

Bulletin I-1(R1)  
10M BP 4/91  
Printed in USA

# Low Voltage Transformers Selection Guide



**SQUARE D**  
GROUPE SCHNEIDER

# Special Purpose Transformers



### Non-Ventilated Transformers

For use in contaminated or dust-laden environments, indoor or outdoor.



### Export Model Transformers

Designed to accommodate voltage systems world-wide.



### Stainless Steel Enclosed Transformers

Built for the most severe environments; featuring superior corrosion resistance.



### Shielded Isolation Transformers

Protect sensitive loads from damaging transients and electrical noise. Models with filters combine the protection of shielding with enhanced low-pass filters to help control the most severe electrical noise and transients.



### Buck and Boost Transformers

Economical space-saving design for providing small changes in voltages to match load requirements.



### Drive Isolation Transformers

Specifically designed for the rigorous demands of ac and dc motor drive loads.



### Mini Power-Zone® Transformers

Combine transformer and circuit breaker distribution panel into one space and labor saving unit.



### NL and NLP Transformers for Non-Linear Loads

K-factor rated specifically to withstand harmonic heating and high neutral currents associated with computer equipment and other single phase electronic loads.



General Purpose Transformers

**General Purpose Transformers**

High quality standard transformers for the majority of routine lighting and power applications.



**WATCHDOG® Energy-Efficient Transformers**

Low temperature rise for energy savings and longer life.

**Copper-Wound Transformers**

To meet specifications or when copper windings are preferred.

<b>Contents</b>	
<b>Product Selection Guidelines</b>	4
General Purpose Transformers	9
Standard Ventilated and Resin-Filled	9
Energy Saving WATCHDOG®	12
With Copper Windings	13
<b>Special Purpose Transformers</b>	14
Non-Ventilated Type	14
Export Model	15
Stainless Steel Enclosure	15
Transformers for Non Linear Loads	16
Shielded Isolation Transformers	17
Buck and Boost	19
MINI POWER-ZONE® Power Supply	24
Drive Isolation Transformers	25
<b>Enclosures, Dimensions and Accessories</b>	26
Lug Kits	26
Enclosures and Accessories	27
Enclosure Styles	28
<b>Other Transformer Products</b>	29
Control Power Transformers	29
Open Core and Coil Transformers	34
Motor Starting Autotransformers	35
Transformer Disconnects	36
<b>Application Information</b>	38

Other Transformer Products

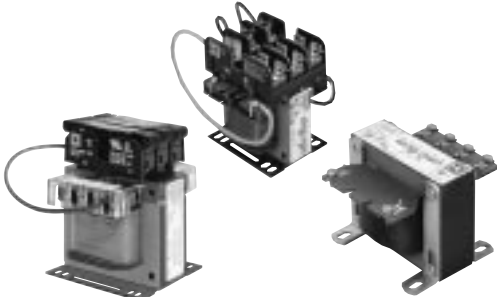

**Control Power Transformers**

Designed to handle high inrush current associated with contactors and relays; available in a variety of designs to meet the needs of panel builders and machinery OEMs.

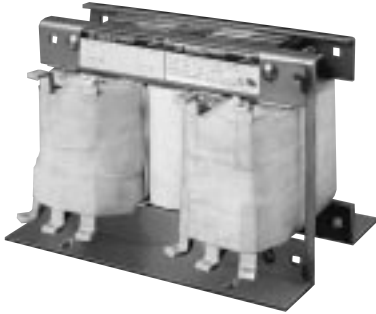

**Motor Starting Autotransformers**

Designed for medium-duty motor starting service. Available in a two- or three-coil design.



**Open Core and Coil Transformers**

Space-saving, compact design for general applications. Available in single- and three- phase.



**Transformer Disconnects**

A convenient source of 120V power that can be used for auxiliary or isolated loads such as panel lighting, portable power tools, and programmable controller equipment.



# Product Selection Guidelines For Low Voltage Transformers

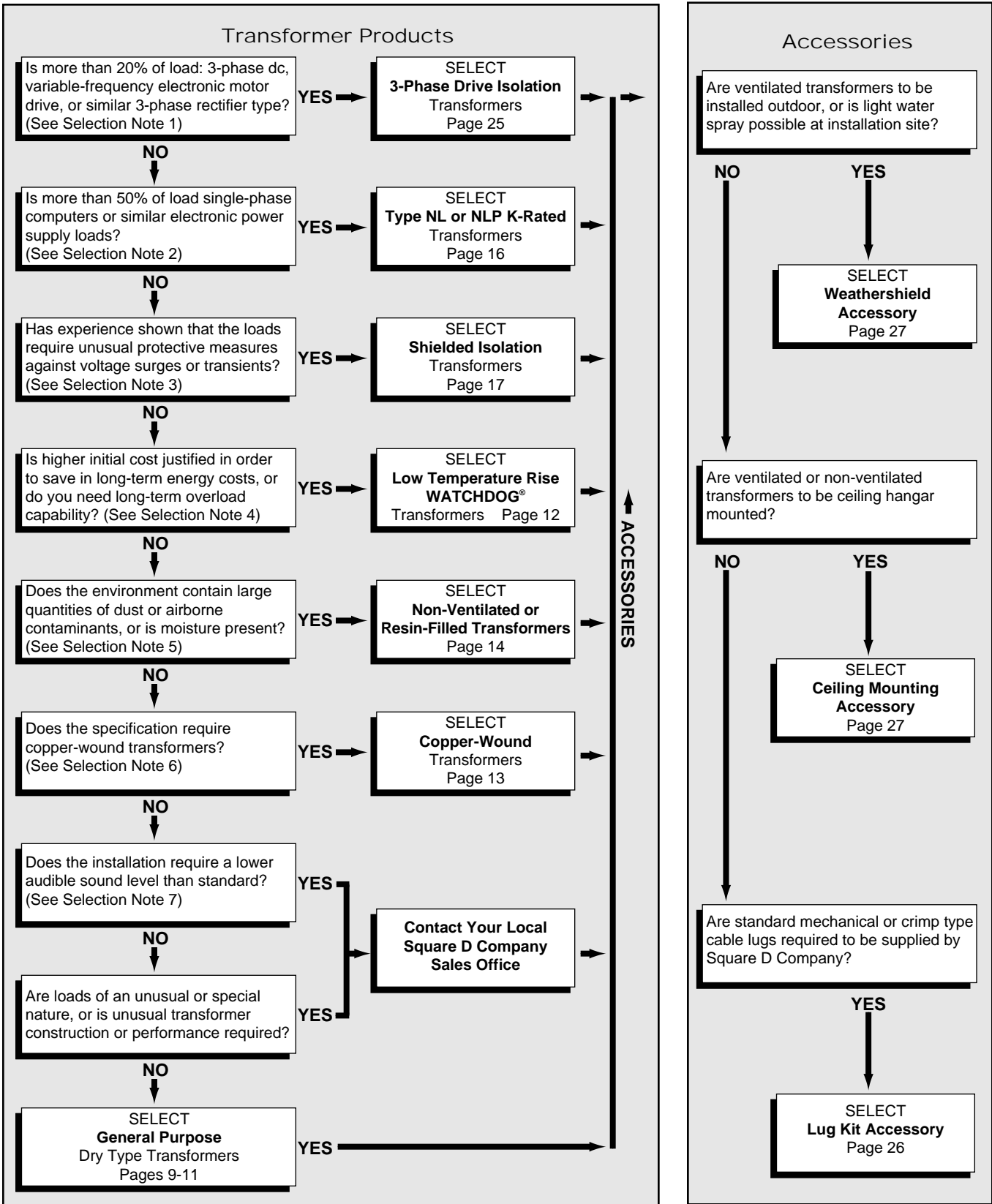

**Note 1: Drive Isolation Transformers**

Drive isolation transformers help reduce voltage distortion caused by ac and dc motor drives. To help reduce drive current distortion, a minimum of 4% reactance should be specified. In addition, the isolation created by separate, electrically insulated secondary windings allows grounding of the load-side neutral. Grounding helps prevent drive generated common-mode electrical noise from passing upstream into the primary system as it would with simple line reactors. Three-phase ac and dc drives cause distorted current to flow in the windings of transformers, creating additional heating. DC drives in particular have high current pulses that cause system voltage notching and stress in transformer windings. Consider this resulting additional heat and mechanical stress when specifying drive isolation transformers.

**Selection Criteria Drive Isolation Transformer:**

The use of standard, general purpose lighting transformers is not recommended for this application. Make sure that your drive transformer has been specifically compensated and tested per UL 1561 procedure for the typical harmonic spectrum for phase converters defined in IEEE-519. In addition, drive transformers must be capable of supplying the drive overload requirements defined as Class B in IEEE-597, and be suitable for 150% load for one minute occurring once per hour.

**Note 2: K-Rated Transformers for Non-Linear Loads**

Many types of single-phase loads cause distorted current waveforms. These loads include common office automation equipment such as personal computers, copiers, facsimile machines, and printers. Other similar loads include single-phase process control systems, lighting controls, UPS systems, and discharge lighting. If the current distortion is high enough, it can cause overheating of system neutrals and transformers. To prevent shortened transformer life expectancy when high harmonic current conditions exist, K-rated transformers are recommended.

**Selection Criteria K-Rated Transformer for Non-Linear Load:**

K-rated transformers should never be specified for three-phase non-linear loads such as motor drives, three phase UPSs, or any three-phase device with SCR phase-control or static-diode input circuits. K-rated transformers are evaluated only for the heating effects of harmonic currents, not for the thermal and mechanical stress of drive loads. These transformers have double-size neutral terminals and, therefore, are intended only for use in high 3rd harmonic-single phase non-linear loads. For transformers specifically designed for high 5th and 7th harmonics and current pulse stress of three-phase converter loads, see Note 1: *Drive Isolation Transformers*.

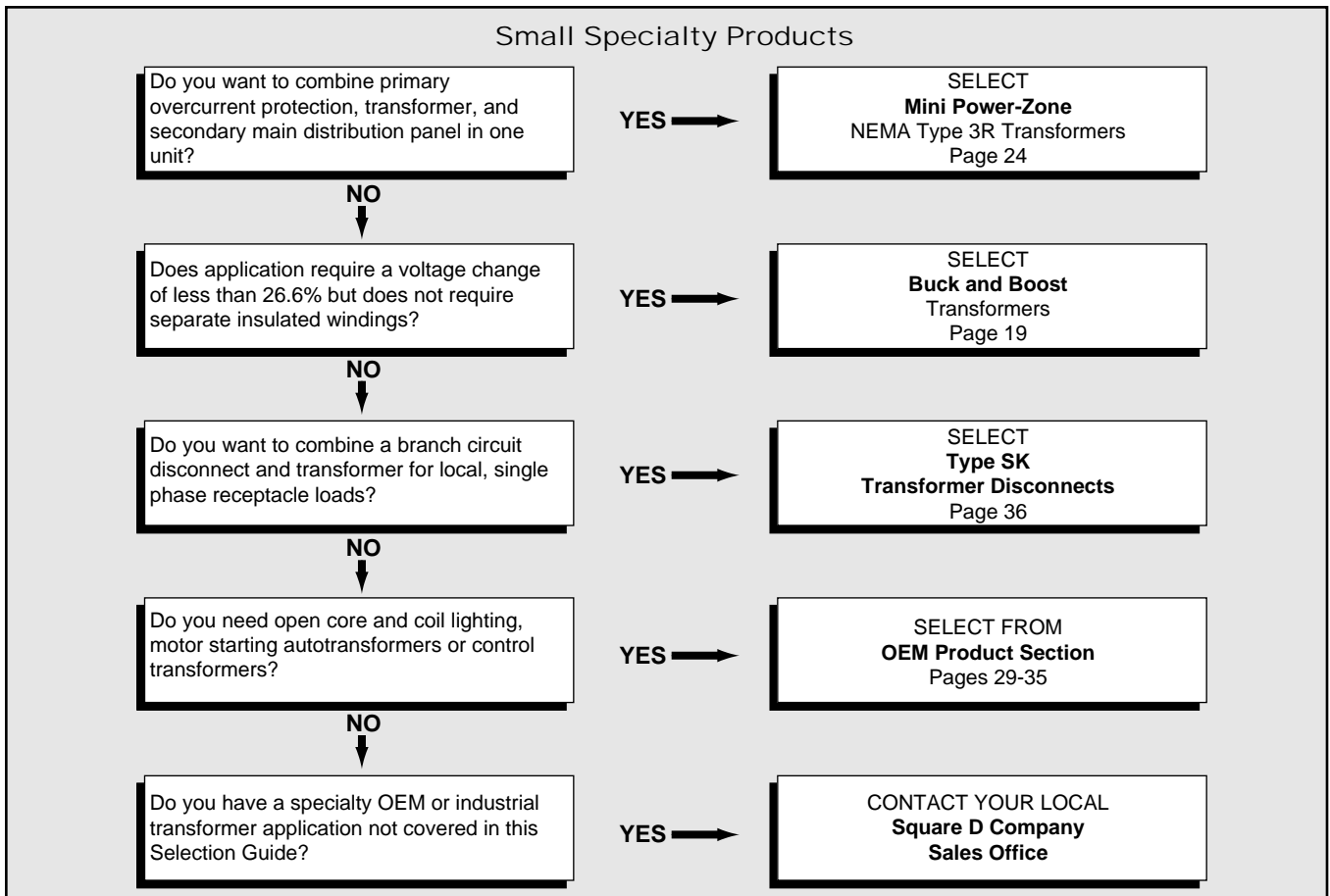



# Product Selection Guidelines

## Selection Notes

### Note 3: Shielded Isolation Transformers

Electrostatic shields in transformers divert some types of electrical noise and transients to ground, providing a moderate amount of load protection from some surges and line disturbances. The addition of secondary filters and primary MOV type surge suppressors provides significant additional protection, particularly from very high-level transient energies.

#### Selection Criteria Shielded Isolation Transformer:

No industry standards exist for testing the performance of electrostatic shields. Many manufacturers use unrealistic test methods using “dry circuit” unenergized transformers and adjust the method to provide the best data for their product. Importantly, the supplier must perform both ring wave and short rise time impulse injection tests in actual, energized, loaded, and grounded installation conditions. NOTE: Isolation transformers without shields provide excellent transient and noise reduction when the secondary is grounded in accordance with the National Electrical Code.

The introduction of shields in transformers improves transient and surge protection for some frequencies, but testing has shown shields can introduce resonances and parasitic oscillations at other frequencies, particularly in the 150 kHz range typically found in industrial applications. *In those ranges, shields can actually amplify the noise and transients, possibly making power quality problems worse.* For this reason, shielded transformers are not recommended to be routinely supplied in all applications. Restrict shield use to protecting loads such as computers, process controls, or other electronic loads from lighting and switching impulses that have much higher frequency components. Use caution in selecting shielded transformers when the loads share feeders with motor controls, switches, contactors, or any load generating arcing type transients on the line. Contact your local Square D field office for application assistance.

### Note 4: Low Temperature Rise Transformers

Transformers can be designed with lower temperature rise than the maximum allowed for the insulation system used in the windings. This creates the benefits of 1) lower conductor loss, potentially lowering the cost of transformer operation, and 2) continuous overload capacity if future expansion is planned, or for temporary loads, such as summertime air conditioning, which will cause the average load to exceed the nameplate rating.

Insulation System	Temp. Rise (Deg. C.)	Continuous Overload Capacity
180	115	0%
180	80	15%
220	150	0%
220	115	15%
220	80	30%

#### Selection Criteria Low Temperature Rise Transformer:

When calculating energy savings for low temperature rise transformers, consider the importance of the average loading of the transformer. Low temperature rise transformers can have significantly higher core losses. Lowered conductor loss typically can overcome the disadvantage of higher core loss only if the load, on average, exceeds 50–70% of the nameplate rating. Statistical estimates show that 75% of all installed transformers, on average, never carry more than a 50% load. Under these light loading conditions, 150°C rise transformers can actually have lower total loss than lower temperature rise designs. Contact your local Square D field office for loss data to properly evaluate your energy costs.



**Note 5: Environmental Considerations**

One of the greatest dangers to ventilated, dry type transformers is the moisture content or presence of contamination in the cooling air that passes through the coil ducts and around the coil conductors. High quantities of airborne fibers or lint can clog air ducts and prevent cooling air from reaching the conductors. Conductive material, such as carbon, metal, or coal dust in the surrounding air, should also be a major concern in transformer selection. Non-ventilated or resin-filled dry type transformers do not have ventilation openings, and therefore provide superior protection from many moisture and contamination problems, in both indoor and outdoor applications.

**Selection Criteria Environmental Considerations:**

Non-ventilated or resin-filled transformers are not gasketed and are not intended to meet requirements of NEMA Type 4 or NEMA Type 12. Non-ventilated or resin-filled transformers can be located outdoor without the addition of weathershields or other accessories.

**Note 6: Copper-Wound Transformers**

Copper-wound transformers are significantly higher in price and weight than the more popular aluminum wound transformers. On average, the losses are equivalent between copper and aluminum transformers. Therefore, the major reason for specification of copper-wound transformers is either preference for copper connections or dimensional restrictions that can only be met by copper windings.

**Selection Criteria Copper-Wound Transformer:**

Before investing in the additional cost of copper-wound transformers, examine the reasons for copper preference in your specifications. Although copper-wound transformers can theoretically be made smaller than aluminum-wound transformers, most manufacturers supply aluminum-wound and copper-wound transformers in the same enclosure size. Many specifier preferences stem from fear that installers will not employ the required installation practices and hardware necessary to make reliable aluminum connections. Aluminum connections are now commonplace in electrical installations. Aluminum-wound transformers are chosen in the majority of United States specifications.

**Note 7: Transformer Sound Levels**

All transformers produce some sound as a necessary part of operation. Standards limit the allowable sound levels to those shown in the following table and are based on the nameplate kVA rating. If sound level is a concern in the location of the transformer, such as near offices, living areas, theater stages, or seating, reduced sound level designs are available to meet your specifications. Contact your local Square D sales office for these special applications.

kVA	NEMA Standard Sound Level
0-9	40 db
10-50	45 db
51-150	50 db
151-300	55 db
301-500	60 db

**Selection Criteria Transformer Sound Levels:**

Apparent sound level is typically reduced by half for every 3 db of sound level reduction. Sound level testing is specified by NEMA standards under special conditions that are not usually present at the job site installation. The presence of reflective surfaces within 10 feet of the transformer can add to the apparent sound of a transformer. In extremely unfavorable installations, such as a theater designed for high acoustical efficiency, the apparent sound of a transformer can be as much as 20 db higher than when tested under NEMA standard conditions. Reduced sound level transformers can represent a significant increase in cost for your project. In addition, reduction beyond 8-10 db is not practical. Make sure to compare this additional cost with either relocation of transformers into different areas or providing better equipment room acoustic treatments. Consider the type of environment where the transformer will be located and choose the construction that best suits the requirement.



# Product Selection Guidelines

## Recommended Ratings

**Table 1: AC Motor Full-Load Running Currents**

Horsepower HP	110–120 Volts		220–240 Volts		440–480 Volts		550–600 Volts	
	Single-Phase	Three-Phase	Single-Phase	Three-Phase	Single-Phase	Three-Phase	Single-Phase	Three-Phase
	A★	A	A	A	A	As	A	A
0.5	9.8	4.0	4.9	2.0	2.5	1.0	2.0	0.8
0.75	13.8	5.6	6.9	2.8	3.5	1.4	2.8	1.1
1	16.0	7.2	8.0	3.6	4.0	1.8	3.2	1.4
1.5	20.0	10.4	10.0	5.2	5.0	2.6	4.0	2.1
2	24.0	13.6	12.0	6.8	6.0	3.4	4.8	2.7
3	34.0	19.2	17.0	9.6	8.5	4.8	6.8	3.9
5	56.0	30.4	28.0	15.2	14.0	7.6	11.2	6.1
7.5	80.0	44.0	40.0	22.0	21.0	11.0	16.0	9.0
10	100.0	56.0	50.0	28.0	26.0	14.0	20.0	11.0
15	135.0	84.0	68.0	42.0	34.0	21.0	27.0	17.0
20	—	108.0	88.0	54.0	44.0	27.0	35.0	22.0
25	—	136.0	110.0	68.0	55.0	34.0	44.0	27.0
30	—	160.0	136.0	80.0	68.0	40.0	54.0	32.0
40	—	208.0	176.0	104.0	88.0	52.0	70.0	41.0
50	—	260.0	216.0	130.0	108.0	65.0	86.0	52.0
60	—	—	—	154.0	—	77.0	—	62.0
75	—	—	—	192.0	—	96.0	—	77.0
100	—	—	—	248.0	—	124.0	—	99.0

★ A= Amperes

**Table 2: Single-Phase, Full Load Currents**

kVA Rating	120V	208V	240V	277V	480V	600V
	Amperes					
0.050	0.416	0.240	0.208	0.181	0.104	0.083
0.075	0.625	0.360	0.312	0.270	0.156	0.125
0.100	0.833	0.480	0.417	0.361	0.208	0.167
0.150	1.25	0.721	0.625	0.541	0.313	0.250
0.250	2.08	1.20	1.04	0.902	0.521	0.417
0.500	4.16	2.40	2.08	1.80	1.04	8.33
0.750	6.25	3.60	3.13	2.70	1.56	1.25
1	8.33	4.81	4.17	3.61	2.08	1.67
1.5	12.5	7.21	6.25	5.42	3.13	2.50
2	16.7	9.62	8.33	7.22	4.17	3.33
3	25.0	14.4	12.5	10.8	6.25	5.0
5	41.6	24.0	20.8	18.0	10.4	0.833
7.5	62.5	36.1	31.3	27.1	15.6	12.5
10	83.3	48.1	41.7	36.1	20.8	16.7
15	125	72.1	62.5	54.2	31.3	25.0
25	208	120	104	90.3	52.1	41.7
37.5	313	180	156	135	78	62.5
50	416	240	208	181	104	83.3
75	625	361	313	271	156	125
100	833	481	417	361	208	167
167	1392	803	695	603	348	278
200	1667	962	833	722	417	333
250	2083	1202	1042	903	521	417

**Table 3: Three-Phase, Full Load Currents**

kVA Rating	208V	240V	480V	600V
	Amperes			
3	8.34	7.23	3.61	2.89
6	16.6	14.4	7.2	5.8
9	25.0	21.7	10.8	8.67
15	41.7	36.1	18.1	14.5
30	83.4	72.3	36.1	28.9
45	125	108	54.2	43.4
75	208	181	90.3	72.3
112.5	313	271	135	108
150	417	361	181	145
225	625	542	271	217
300	831	723	361	289
500	1390	1204	602	482
750	2082	1804	902	722
1000	2776	2406	1203	962
1500	4164	3609	1804	1443
2000	5552	4811	2406	1925
2500	6940	6014	3007	2406
3750	10409	9021	4511	3609



# General Purpose Dry Type Transformers

## Standard Ventilated and Resin-Filled



Ventilated  
15–750 kVA



Resin-Filled  
0.05–30 kVA

### Application

General purpose standard transformers are intended for power, heating, and lighting applications.

### Ventilated-Type

All ventilated transformers have core and coil assemblies mounted on rubber isolation pads to minimize the sound level. Vented openings in the enclosure allow air to flow directly over the core-and-coil assembly for cooling. Each is manufactured and tested to meet or exceed IEEE, NEMA and ANSI standards. Their compact size permits installation near the load being supplied. Adding weathershields allows these normally indoor rated units to be used outdoors.

### Resin-Filled

Resin-filled general purpose transformers are epoxy encapsulated. The enclosure has no openings, making resin-filled transformers ideal for use indoor or outdoor where airborne particles or contaminants could be detrimental to operation. The core-and-coil assembly is embedded in an epoxy resin compound and wall mounted for maximum protection. These units can be used outdoor without accessories.

### Single Phase

kVA	Catalog Number	Full Capacity Taps★	Deg. C. Temp. Rise	Wt. (lbs)	Encl. ■	Wiring ♦
<b>240 x 480 Volts Primary 120/240 Volts Secondary 60 Hz</b>						
0.050	<b>50SV1A</b>	None	55	4.2	1A	1
0.100	<b>100SV1A</b>	None	55	4.5	2A	1
0.150	<b>150SV1A</b>	None	55	6.2	3A	1
0.250	<b>250SV1B</b>	None	80	10.5	4A	1
0.500	<b>500SV1B</b>	None	80	13.8	5A	1
0.750	<b>750SV1F</b>	None	115	15.5	6A	1
1	<b>1S1F</b>	None	115	21.2	7A	1
1.5	<b>1.5S1F</b>	None	115	30.1	8A	1
2	<b>2S1F</b>	None	115	39.1	9A	1
3	<b>3S1F</b>	None	115	55.2	10A	1
5	<b>5S1F</b>	None	115	115	13B	1
7.5	<b>7S1F</b>	None	115	150	13B	1
10	<b>10S1F</b>	None	115	165	13B	1
15	<b>15S1H</b>	None	150	200	17D	1
25	<b>25S3H</b>	6–2.5%2+4-▲	150	230	17D	3
37.5	<b>37S3H</b>	6–2.5%2+4-▲	150	325	18D	3
50	<b>50S3H</b>	6–2.5%2+4-▲	150	350	18D	3
75	<b>75S3H</b>	6–2.5%2+4-▲	150	495	21D	3
100	<b>100S3H</b>	6–2.5%2+4-▲	150	705	22D	3
167	<b>167S3H</b>	6–2.5%2+4-▲	150	1020	24D	3

**Note:** Boldface catalog numbers indicate in-stock transformers.  
 ★ (FCBN) Full Capacity Taps Below Normal where noted.  
 ■ For enclosure styles, see **Dimensions Table**, Page 27.  
 ♦ See **Wiring Diagrams**, Page 41.  
 ▲ When 240V connection is used there will be 3-5% taps, 1 above and 2 below 240 volts.

### Single Phase

kVA	Catalog Number	Full Capacity Taps★	Deg. C. Temp. Rise	Wt. (lbs)	Encl. ■	Wiring ♦
<b>480 Volts Primary, 120/240 Volts Secondary 60 Hz</b>						
3	<b>3S40F</b>	2–5%FCBN	115	55.2	10A	28
5	<b>5S40F</b>	2–5%FCBN	115	115	13B	28
7.5	<b>7S40F</b>	2–5%FCBN	115	150	13B	28
10	<b>10S40F</b>	2–5%FCBN	115	165	13B	28
15	<b>15S40F</b>	2–5%FCBN	115	320	15B	28
15	<b>15S40H</b>	2–5%FCBN	150	200	17D	18
25	<b>25S40F</b>	2–5%FCBN	115	385	15B	28
<b>600 Volts Primary, 120/240 Volts Secondary 60 Hz</b>						
0.050	<b>50SV51A</b>	None	55	4.2	1A	6
0.100	<b>100SV51A</b>	None	55	4.5	2A	6
0.150	<b>150SV51A</b>	None	55	6.2	3A	6
0.250	<b>250SV51B</b>	None	80	10.5	4A	6
0.500	<b>500SV51B</b>	None	80	13.8	5A	6
0.750	<b>750SV51F</b>	None	115	15.5	6A	6
1	<b>1S51F</b>	None	115	21.2	7A	6
1.5	<b>1.5S51F</b>	None	115	30.1	8A	6
2	<b>2S51F</b>	None	115	39.1	9A	6
3	<b>3S4F</b>	2–5%FCBN	115	55.2	10A	28
5	<b>5S4F</b>	2–5%FCBN	115	115	13B	28
7.5	<b>7S4F</b>	2–5%FCBN	115	150	13B	28
10	<b>10S4F</b>	2–5%FCBN	115	165	13B	28
15	<b>15S5H</b>	4–2.5%FCBN	150	200	17D	19
25	<b>25S5H</b>	4–2.5%FCBN	150	230	17D	19
37.5	<b>37S5H</b>	4–2.5%FCBN	150	325	18D	19
50	<b>50S5H</b>	4–2.5%FCBN	150	350	18D	19
75	<b>75S5H</b>	4–2.5%FCBN	150	495	21D	19
100	<b>100S5H</b>	4–2.5%FCBN	150	705	22D	19
167	<b>167S5H</b>	4–2.5%FCBN	150	1020	24D	19



# General Purpose Dry Type Transformers Standard Ventilated and Resin-Filled

## Three Phase

kVA	Catalog Number	Full Capacity Taps★	Deg. C. Temp. Rise	Wt. (lbs)	Encl. ■	Wiring ♦
<b>480 Volts Delta Primary 208Y/120 Volts Secondary 60 Hz</b>						
3	<b>3T2F</b>	2—5%FCBN	115	125	12C	8
6	<b>6T2F</b>	2—5%FCBN	115	150	12C	8
9	<b>9T2F</b>	2—5%FCBN	115	265	14C	8
15	<b>15T2F</b>	2—5%FCBN	115	335	14C	8
15	<b>15T68F</b>	4—2.5%2+2-	115	335	14C	9
15	<b>15T3H</b>	6—2.5%2+4-	150	200	17D	10
30	<b>30T2F</b>	2—5%FCBN	115	775	16C	29
30	<b>30T3H</b>	6—2.5%2+4-	150	250	17D	10
45	<b>45T3H</b>	6—2.5%2+4-	150	340	18D	10
75	<b>75T3H</b>	6—2.5%2+4-	150	500	19D	10
112.5	<b>112T3H</b>	6—2.5%2+4-	150	750	21D	10
150	<b>150T3H</b>	6—2.5%2+4-	150	1020	22D	10
225	<b>225T3H</b>	6—2.5%2+4-	150	1275	24D	10
300	<b>300T3H</b>	6—2.5%2+4-	150	1680	25D	10
500	<b>500T68H</b>	4—2.5%2+2-	150	2460	30D	11
750	<b>750T90H</b>	4—3.5%2+2-	150	3250	31D	11
1000	<b>1000T77H</b>	2—5%1+1-	150	6300	33F	16

kVA	Catalog Number	Full Capacity Taps★	Deg. C. Temp. Rise	Wt. (lbs)	Encl. ■	Wiring ♦
<b>480 Volts Delta Primary 240 Volts Delta Secondary 60 Hz</b>						
6	<b>6T5F</b>	2—5%FCBN	115	150	12C	12
9	<b>9T75F</b>	4—2.5%FCBN	115	265	14C	13
15	<b>15T75F</b>	4—2.5%FCBN	115	335	14C	13
15	<b>15T6H</b>	6—2.5%2+4-	150	200	17D	14
30	<b>30T6H</b>	6—2.5%2+4-	150	250	17D	14
45	<b>45T6H</b>	6—2.5%2+4-	150	340	18D	14
75	<b>75T6H</b>	6—2.5%2+4-	150	500	19D	14
112.5	<b>112T6H</b>	6—2.5%2+4-	150	750	21D	14
150	<b>150T6H</b>	6—2.5%2+4-	150	1020	22D	14
225	<b>225T6H</b>	6—2.5%2+4-	150	1275	24D	14
300	<b>300T6H</b>	6—2.5%2+4-	150	1680	25D	14
500	<b>500T63H</b>	4—2.5%2+2-	150	2460	30D	15
750	<b>750T91H</b>	4—3.5%2+2-	150	3250	31D	15
1000	<b>1000T78H</b>	2—5%1+1-	150	6000	33F	17

## Three Phase

kVA	Catalog Number	Full Capacity Taps★	Deg. C. Temp. Rise	Wt. (lbs)	Encl. ■	Wiring ♦
<b>480 Volts Delta Primary 240 Volts Delta Secondary 120 Volts CENTER TAP 60 Hz</b>						
30	<b>30T6HCT</b>	6—2.5%2+4-	150	250	17D	20
45	<b>45T6HCT</b>	6—2.5%2+4-	150	340	18D	20
75	<b>75T6HCT</b>	6—2.5%2+4-	150	500	19D	20
112.5	<b>112T6HCT</b>	6—2.5%2+4-	150	750	21D	20
150	<b>150T6HCT</b>	6—2.5%2+4-	150	1020	22D	20
225	<b>225T6HCT</b>	6—2.5%2+4-	150	1275	24D	20
300	<b>300T6HCT</b>	6—2.5%2+4-	150	1680	25D	20
500	<b>500T63HCT</b>	4—2.5%2+2-	150	2460	30D	33
750	<b>750T91HCT</b>	4—3.5%2+2-	150	3250	31D	26
1000	<b>1000T78HCT</b>	2—5%1+1-	150	6300	33F	27

kVA	Catalog Number	Full Capacity Taps★	Deg. C. Temp. Rise	Wt. (lbs)	Encl. ■	Wiring ♦
<b>480 Volts Delta Primary 480Y/277 Volts Secondary 60 Hz</b>						
15	<b>15T76H</b>	4—2.5%2+ 2-	150	200	17D	11
30	<b>30T76H</b>	4—2.5%2+ 2-	150	250	17D	11
45	<b>45T76H</b>	4—2.5%2+ 2-	150	340	18D	11
75	<b>75T76H</b>	4—2.5%2+ 2-	150	500	19D	11
112.5	<b>112T76H</b>	4—2.5%2+ 2-	150	750	21D	11
150	<b>150T76H</b>	4—2.5%2+ 2-	150	1020	22D	11
225	<b>225T76H</b>	4—2.5%2+ 2-	150	1275	24D	11
300	<b>300T76H</b>	4—2.5%2+ 2-	150	1680	25D	11
500	<b>500T76H</b>	4—2.5%2+ 2-	150	2460	30D	11

kVA	Catalog Number	Full Capacity Taps★	Deg. C. Temp. Rise	Wt. (lbs)	Encl. ■	Wiring ♦
<b>480 Volts Delta Primary 380Y/220 Volts Secondary 60 Hz</b>						
15	<b>15T96H</b>	4—2.5%2+ 2-	150	200	17D	11
30	<b>30T96H</b>	4—2.5%2+ 2-	150	250	17D	11
45	<b>45T96H</b>	4—2.5%2+ 2-	150	340	18D	11
75	<b>75T96H</b>	4—2.5%2+ 2-	150	500	19D	11
112.5	<b>112T96H</b>	4—2.5%2+ 2-	150	750	21D	11
150	<b>150T96H</b>	4—2.5%2+ 2-	150	1020	22D	11
225	<b>225T96H</b>	4—2.5%2+ 2-	150	1275	24D	11
300	<b>300T96H</b>	4—2.5%2+ 2-	150	1680	25D	11
500	<b>500T96H</b>	4—2.5%2+ 2-	150	2460	30D	11

**Note:** Boldface Catalog Numbers indicate in-stock transformers.  
 ★ (FCBN) Full Capacity Taps Below Normal where noted.  
 ■ For enclosure styles see **Dimensions Table** Page 27.  
 ♦ See **Wiring Diagrams** Page 41.



# General Purpose Transformers Standard Ventilated and Resin-filled

## Three Phase

kVA	Catalog Number	Full Capacity Taps★	Deg. C. Temp. Rise	Wt. (lbs)	Encl. ■	Wiring ♦
<b>600 Volts Delta Primary 208Y/120 Volts Secondary 60 Hz</b>						
6	<b>6T7F</b>	2—5%FCBN	115	150	12C	8
9	<b>9T7F</b>	2—5%FCBN	115	265	14C	8
15	<b>15T7F</b>	2—5%FCBN	115	335	14C	8
15	15T8H	4—2.5%FCBN	150	200	17D	11
30	<b>30T8H</b>	4—2.5%FCBN	150	250	17D	11
45	<b>45T8H</b>	4—2.5%FCBN	150	340	18D	11
75	<b>75T8H</b>	4—2.5%FCBN	150	500	19D	11
112.5	112T8H	4—2.5%FCBN	150	750	21D	11
150	150T8H	4—2.5%FCBN	150	1020	22D	11
225	225T8H	4—2.5%FCBN	150	1275	24D	11
300	300T8H	4—2.5%FCBN	150	1680	25D	11
500	500T8H	4—2.5%FCBN	150	2460	30D	11
750	750T8H	4—2.5%FCBN	150	3250	31D	11
1000	1000T88H	4—3.5%FCBN	150	6000	33F	11
<b>600 Volts Delta Primary 480Y/277 Volts Secondary 60 Hz</b>						
15	15T74H	4—2.5%FCBN	150	200	17D	11
30	30T74H	4—2.5%FCBN	150	250	17D	11
45	45T74H	4—2.5%FCBN	150	340	18D	11
75	75T74H	4—2.5%FCBN	150	500	19D	11
112.5	112T74H	4—2.5%FCBN	150	750	21D	11
150	150T74H	4—2.5%FCBN	150	1020	22D	11
225	225T74H	4—2.5%FCBN	150	1275	24D	11
300	300T74H	4—2.5%FCBN	150	1680	25D	11
500	500T74H	4—2.5%FCBN	150	2460	30D	11
<b>600 Volts Delta Primary 240 Volts Delta Secondary 60 Hz</b>						
15	15T10H	4—2.5%FCBN	150	200	17D	15
30	30T10H	4—2.5%FCBN	150	250	17D	15
45	45T10H	4—2.5%FCBN	150	340	18D	15
75	75T10H	4—2.5%FCBN	150	500	19D	15
112.5	112T10H	4—2.5%FCBN	150	750	21D	15
150	150T10H	4—2.5%FCBN	150	1020	22D	15
225	225T10H	4—2.5%FCBN	150	1275	24D	15
300	300T10H	4—2.5%FCBN	150	1680	25D	15
500	500T10H	4—2.5%FCBN	150	2460	30D	15

## Three Phase

kVA	Catalog Number	Full Capacity Taps★	Deg. C. Temp. Rise	Wt. (lbs)	Encl. ■	Wiring ♦
<b>208 Volts Delta Primary 480Y/277 Volts Secondary 60 Hz</b>						
15	<b>15T64H</b>	2—5%FCBN	150	200	17D	30
30	<b>30T64H</b>	2—5%FCBN	150	250	17D	30
45	<b>45T64H</b>	2—5%FCBN	150	340	18D	30
75	<b>75T64H</b>	2—5%FCBN	150	500	19D	30
112.5	<b>112T64H</b>	2—5%FCBN	150	750	21D	30
150	<b>150T64H</b>	2—5%FCBN	150	1020	22D	30
225	225T64H	2—5%FCBN	150	1275	24D	30
300	300T64H	2—5%FCBN	150	1680	25D	30
500	500T64H	2—5%FCBN	150	2460	30D	30
<b>240 Volts Delta Primary 208Y/120 Volts Secondary 60 Hz</b>						
15	<b>15T12H</b>	4—2.5%2+ 2-	150	200	17D	11
30	<b>30T12H</b>	4—2.5%2+ 2-	150	250	17D	11
45	<b>45T12H</b>	4—2.5%2+ 2-	150	340	18D	11
75	<b>75T12H</b>	4—2.5%2+ 2-	150	500	19D	11
112.5	<b>112T12H</b>	4—2.5%2+ 2-	150	750	21D	11
150	<b>150T12H</b>	4—2.5%2+ 2-	150	1020	22D	11
225	225T11H	2—5%FCBN	150	1275	24D	16
300	300T11H	2—5%FCBN	150	1680	25D	16
500	500T11H	2—5%FCBN	150	2460	30D	16

**Note:** Boldface Catalog Numbers indicate in-stock transformers.  
 ★ (FCBN) Full Capacity Taps Below Normal where noted.  
 ■ For enclosure styles see **Dimensions Table** Page 27.  
 ♦ See **Wiring Diagrams** Page 41.



# General Purpose Transformers

## Energy Saving Premium WATCHDOG® Type



Typical Dry Type General Purpose Energy Saving Premium WATCHDOG® Type

Energy saving WATCHDOG® transformers have these special features:

- Designed for higher efficiency at minimum operating cost.
- Constructed for an extra-long life expectancy using 220°C insulation system designed for full load operation at a maximum temperature rise of 115°C or 80°C above 40°C ambient, instead of 150° rise.
- Capable of continuous emergency overload at 15% on 115°C rise, 30% on 80°C rise.

### Single Phase

kVA	Catalog Number	Full Capacity Taps	Deg. C. Temp. Rise	Wt. (lbs)	Encl. ■	Wiring ♦
<b>240 x 480 Volts Primary, 120/240 Volts Secondary 60 Hz</b>						
15	<b>15S3HF</b>	6—2.5%2+4- ▲	115	230	17D	3
25	<b>25S3HF</b>	6—2.5%2+4- ▲	115	325	18D	3
37.5	<b>37S3HF</b>	6—2.5%2+4- ▲	115	350	18D	3
50	<b>50S3HF</b>	6—2.5%2+4- ▲	115	495	21D	3
75	75S3HF	6—2.5%2+4- ▲	115	705	22D	3
100	100S3HF	6—2.5%2+4- ▲	115	1020	24D	3
<b>240 x 480 Volts Primary, 120/240 Volts Secondary 60 Hz</b>						
15	<b>15S3HB</b>	6—2.5%2+4- ▲	80	230	17D	3
25	<b>25S3HB</b>	6—2.5%2+4- ▲	80	325	18D	3
37.5	<b>37S3HB</b>	6—2.5%2+4- ▲	80	350	18D	3
50	<b>50S3HB</b>	6—2.5%2+4- ▲	80	495	21D	3
75	75S3HB	6—2.5%2+4- ▲	80	705	22D	3
100	100S3HB	6—2.5%2+4- ▲	80	1020	24D	3

### Three Phase

kVA	Catalog Number	Full Capacity Taps	Deg. C. Temp. Rise	Wt. (lbs)	Encl. ■	Wiring ♦
<b>480 Volts Delta Primary, 208Y/120 Volts Secondary 60 Hz</b>						
15	<b>15T3HF</b>	6—2.5%2+4-	115	250	17D	10
30	<b>30T3HF</b>	6—2.5%2+4-	115	340	18D	10
45	<b>45T3HF</b>	6—2.5%2+4-	115	500	19D	10
75	<b>75T3HF</b>	6—2.5%2+4-	115	650	21D	10
112.5	<b>112T3HF</b>	6—2.5%2+4-	115	1020	22D	10
150	<b>150T3HF</b>	6—2.5%2+4-	115	1275	24D	10
225	<b>225T3HF</b>	6—2.5%2+4-	115	1680	25D	10
300	<b>300T3HF</b>	6—2.5%2+4-	115	2460	30D	10
500	500T90HF	4—3.5%2+2-	115	3250	31D	11
<b>480 Volts Delta Primary, 208Y/120 Volts Secondary 60 Hz</b>						
15	<b>15T3HB</b>	6—2.5%2+4-	80	250	17D	10
30	<b>30T3HB</b>	6—2.5%2+4-	80	340	18D	10
45	<b>45T3HB</b>	6—2.5%2+4-	80	500	19D	10
75	<b>75T3HB</b>	6—2.5%2+4-	80	750	21D	10
112.5	<b>112T3HB</b>	6—2.5%2+4-	80	1020	22D	10
150	<b>150T3HB</b>	6—2.5%2+4-	80	1275	24D	10
225	<b>225T3HB</b>	6—2.5%2+4-	80	1680	25D	10
300	<b>300T3HB</b>	6—2.5%2+4-	80	2460	30D	10
500	500T90HB	4—3.5%2+2-	80	3250	31D	11

**Note:** Boldface Catalog Numbers indicate in-stock transformers.

■ For enclosure styles see **Dimensions Table** Page 27.

♦ See **Wiring Diagrams** Page 41.

▲ When 240V connection is used there will be 3-5% taps, 1 above and 2 below 240 volts.



# General Purpose Dry Type Transformers With Copper Windings



Typical Dry Type General Purpose Transformer  
with Copper Windings

Aluminum windings in general purpose transformers can be replaced with copper windings which are preferred by some customers.

### Three Phase

kVA	Catalog Number	Full Capacity Taps	Deg. C. Temp. Rise	Wt. (lbs)	Encl. ■	Wiring ♦
<b>480 Volts Delta Primary 208Y/120 Volts Secondary 60 Hz</b>						
15	<b>15T3HCU</b>	6—2.5%2+4-	150	240	17D	10
30	<b>30T3HCU</b>	6—2.5%2+4-	150	300	17D	10
45	<b>45T3HCU</b>	6—2.5%2+4-	150	385	18D	10
75	<b>75T3HCU</b>	6—2.5%2+4-	150	600	19D	10
112.5	<b>112T3HCU</b>	6—2.5%2+4-	150	780	21D	10
150	<b>150T3HCU</b>	6—2.5%2+4-	150	1080	22D	10
225	<b>225T3HCU</b>	6—2.5%2+4-	150	1520	24D	10
300	<b>300T3HCU</b>	6—2.5%2+4-	150	1920	25D	10
500	500T68HCU	4—2.5%2+2-	150	2550	30D	11
750	750T90HCU	4—3.5%2+2-	150	3800	31D	11

### 480 Volts Delta Primary 240 Volts Delta Secondary 60 Hz

15	15T6HCU	6—2.5%2+4-	150	240	17D	14
30	30T6HCU	6—2.5%2+4-	150	300	17D	14
45	45T6HCU	6—2.5%2+4-	150	385	18D	14
75	75T6HCU	6—2.5%2+4-	150	600	19D	14
112.5	112T6HCU	6—2.5%2+4-	150	780	21D	14
150	150T6HCU	6—2.5%2+4-	150	1080	22D	14
225	225T6HCU	6—2.5%2+4-	150	1520	24D	14
300	300T6HCU	6—2.5%2+4-	150	1920	25D	14
500	500T63HCU	4—2.5%2+2-	150	2550	30D	15

### Three Phase

kVA	Catalog Number	Full Capacity Taps	Deg. C. Temp. Rise	Wt. (lbs)	Encl. ■	Wiring ♦
<b>600 Volts Delta Primary 208Y/120 Volts Secondary 60 Hz</b>						
15	15T79HCU	4—2.5%2+2-	150	240	17D	11
30	30T79HCU	4—2.5%2+2-	150	300	17D	11
45	45T79HCU	4—2.5%2+2-	150	385	18D	11
75	75T79HCU	4—2.5%2+2-	150	600	19D	11
112.5	112T79HCU	4—2.5%2+2-	150	780	21D	11
150	150T79HCU	4—2.5%2+2-	150	1080	22D	11
225	225T79HCU	4—2.5%2+2-	150	1520	24D	11
300	300T79HCU	4—2.5%2+2-	150	1920	25D	11
500	500T79HCU	4—2.5%2+2-	150	2550	30D	11
750	750T79HCU	4—2.5%2+2-	150	3800	31D	11

### 600 Volts Delta Primary 240 Volts Delta Secondary 60 Hz

15	15T129HCU	4—2.5%2+2-	150	240	17D	15
30	30T129HCU	4—2.5%2+2-	150	300	17D	15
45	45T129HCU	4—2.5%2+2-	150	385	18D	15
75	75T129HCU	4—2.5%2+2-	150	600	19D	15
112.5	112T129HCU	4—2.5%2+2-	150	780	21D	15
150	150T129HCU	4—2.5%2+2-	150	1080	22D	15
225	225T129HCU	4—2.5%2+2-	150	1520	24D	15
300	300T129HCU	4—2.5%2+2-	150	1920	25D	15
500	500T129HCU	4—2.5%2+2-	150	2550	30D	15

**Note:** Boldface Catalog Numbers indicate in-stock transformers.

■ For enclosure styles see **Dimensions Table** Page 27.

♦ See **Wiring Diagrams** Page 41.





# Special Purpose Transformers

## Non-Ventilated Type



Typical Non-Ventilated Transformer

Non-ventilated transformers are intended for use in contaminated or dust-laden environments, indoor or outdoor.

### Single Phase

kVA	Catalog Number	Full Capacity Taps★	Deg. C. Temp. Rise	Wt. (lbs)	Encl. ■	Wiring ♦
<b>240 x 480 Volts Primary</b>						
<b>120/240 Volts Secondary 60 Hz</b>						
15	15S3HNV	6—2.5%2+4-▲	150	230	17E	3
25	25S3HNV	6—2.5%2+4-▲	150	310	18E	3
37.5	37S3HNV	6—2.5%2+4-▲	150	350	18E	3
50	50S3HNV	6—2.5%2+4-▲	150	495	21E	3
75	75S3HNV	6—2.5%2+4-▲	150	1020	24E	3
100	100S3HNV	6—2.5%2+4-▲	150	1220	25E	3
<b>600 Volts Primary</b>						
<b>120/240 Volts Secondary 60 Hz</b>						
15	15S5HNV	4—2.5%FCBN	150	230	17E	19
25	25S5HNV	4—2.5%FCBN	150	310	18E	19
37.5	37S5HNV	4—2.5%FCBN	150	350	18E	19
50	50S5HNV	4—2.5%FCBN	150	495	21E	19
75	75S5HNV	4—2.5%FCBN	150	1020	24E	19
100	100S5HNV	4—2.5%FCBN	150	1220	25E	19

**Note:** Boldface Catalog Numbers indicate in-stock transformers.  
 ★ (FCBN) Full Capacity Taps Below Normal where noted.  
 ■ For enclosure styles see **Dimensions Table** Page 27.  
 ♦ See **Wiring Diagrams** Page 41.  
 ▲ When 240V connection is used there will be 3-5% taps, 1 above and 2 below 240V.

### Three Phase

kVA	Catalog Number	Full Capacity Taps★	Deg. C. Temp. Rise	Wt. (lbs)	Encl. ■	Wiring ♦
<b>480 Volts Delta Primary</b>						
<b>208Y/120 Volts Secondary 60 Hz</b>						
15	<b>15T68F</b>	4—2.5%2+2-	115	335	14C	9
30	<b>30T2F</b>	2—5%FCBN	115	775	16C	29
30	<b>30T3HNV</b>	6—2.5%2+4-	150	340	19E	10
45	<b>45T3HNV</b>	6—2.5%2+4-	150	510	19E	10
75	<b>75T3HNV</b>	6—2.5%2+4-	150	1020	22E	10
112.5	112T3HNV	6—2.5%2+4-	150	1275	24E	10
150	150T3HNV	6—2.5%2+4-	150	1680	25E	10
225	225T3HNV	6—2.5%2+4-	150	2100	23E	10
300	300T3HNV	6—2.5%2+4-	150	3300	28E	10
<b>480 Volts Delta Primary</b>						
<b>240 Volts Delta Secondary 60 Hz</b>						
15	<b>15T75F</b>	4—2.5%FCBN	115	335	14C	13
30	30T6HNV	6—2.5%2+4-	150	340	19E	14
45	45T6HNV	6—2.5%2+4-	150	510	19E	14
75	75T6HNV	6—2.5%2+4-	150	1020	22E	14
112.5	112T6HNV	6—2.5%2+4-	150	1275	24E	14
150	150T6HNV	6—2.5%2+4-	150	1680	25E	14
225	225T6HNV	6—2.5%2+4-	150	2100	23E	14
300	300T6HNV	6—2.5%2+4-	150	3300	28E	14
<b>600 Volts Delta Primary</b>						
<b>208Y/120 Volts Secondary 60 Hz</b>						
15	<b>15T7F</b>	2—5%FCBN	115	335	14C	8
30	30T8HNV	4—2.5%FCBN	150	340	19E	11
45	45T8HNV	4—2.5%FCBN	150	510	19E	11
75	75T8HNV	4—2.5%FCBN	150	1020	22E	11
112.5	112T8HNV	4—2.5%FCBN	150	1275	24E	11
150	150T8HNV	4—2.5%FCBN	150	1680	25E	11
225	225T8HNV	4—2.5%FCBN	150	2100	23E	11
300	300T8HNV	4—2.5%FCBN	150	3300	28E	11



## Special Purpose Transformers Export Model and Stainless Steel Enclosure



Typical Export Model Transformer



Typical Stainless Steel Enclosure

Export model transformers are designed to accommodate voltage systems world-wide.

Export model transformers 10kVA and smaller are certified by TUV (file no. E9571881.01) to meet EN standard EN60-742 in addition to being UL Listed. Original equipment is eligible for the "CE" mark if transformer components meet the EN60-742 standard. Because the EN standard has a more severe overload requirement, the 1S67F has a UL rating of 1kVA but an EN rating of 0.750kVA.

### Single Phase

kVA	Catalog Number	Full Capacity Taps	Deg. C. Temp. Rise	Wt. (lbs)	Encl. ■	Wiring ♦
<b>190/200/208/220 x 380/400/416/440 Volts Primary 110/220 Volts Secondary 50/60 Hz</b>						
1*	<b>1S67F</b>	None	115	21.2	9A	31
2	<b>2S67F</b>	None	115	39.1	11A	31
3	<b>3S67F</b>	None	115	55.2	11A	31
5	<b>5S67F</b>	None	115	135	13B	31
7.5	<b>7S67F</b>	None	115	165	13B	31
10	<b>10S67F</b>	None	115	165	13B	31
15	15S67H	None	150	225	17D	32
25	25S67H	None	150	260	17D	32

**Note:** Boldface Catalog Numbers indicate in-stock transformers.

\* 0.750kVA EN rating.

★ (FCBN) Full Capacity Taps Below Normal where noted.

■ For enclosure styles see **Dimensions Table** Page 27.

♦ See **Wiring Diagrams** Page 41.

Stainless steel enclosures provide better corrosion resistance than standard painted enclosures. Square D has an entire line of resin-filled transformers available with #316 stainless steel enclosures to meet demands for extra protection in environments where harsh chemicals or corrosive materials such as acids, food products, gasoline, organic solvents, or salt water are present.

Square D transformers with #316 stainless steel have a higher nickel content than #304 stainless steel, making them even more resistant to harsh environments.

Units are painted with standard ANSI 49 gray and have a NEMA Type 3R rating. Additional voltages not listed below are available. Contact your local Square D field office for details.

### Single Phase

kVA	Catalog Number	Full Capacity Taps★	Deg. C. Temp. Rise	Wt. (lbs)	Encl. ■	Wiring ♦
<b>240 x 480 Volts Primary 120/240 Volts Secondary 60 Hz</b>						
1	1S1FSS	None	115	21	7A	1
1.5	1.5S1FSS	None	115	30	8A	1
2	2S1FSS	None	115	39	9A	1
3	3S1FSS	None	115	55.2	10A	1
5	5S1FSS	None	115	115	13B	1
7.5	7S1FSS	None	115	150	13B	1
10	10S1FSS	None	115	165	13B	1
15	15S1FSS	None	115	320	15B	1
25	25S1FSS	None	115	385	15B	1

### 480 Volts Primary 120/240 Volts Secondary 60 Hz

3	3S40FSS	2-5% FCBN	115	55.2	10A	28
5	5S40FSS	2-5% FCBN	115	115	13B	28
7.5	7S40FSS	2-5% FCBN	115	150	13B	28
10	10S40FSS	2-5% FCBN	115	165	13B	28
15	15S40FSS	2-5% FCBN	115	320	15B	28
25	25S40FSS	2-5% FCBN	115	385	15B	28

### Three Phase

#### 480 Volts Primary 208Y/120 Volts Secondary 60 Hz

3	3T2FSS	2-5% FCBN	115	125	12C	8
6	6T2FSS	2-5% FCBN	115	150	12C	8
9	9T2FSS	2-5% FCBN	115	265	14C	8
15	15T2FSS	2-5% FCBN	115	335	14C	8
30	30T2FSS	2-5% FCBN	115	775	16C	29



# Special Purpose Transformers

## Transformers for Non-Linear Loads

### Standard NL Model and Premium NLP Model

#### Application

Type NL and NLP are dry type transformers intended to feed applications such as computers, copiers, printers, FAX machines, video display terminals and other equipment having switching-mode power supplies. These transformers are specially built to handle high harmonics associated with such loads. Type NLP is designed particularly for more severe non-linear applications and has reduced sound levels three decibels below NEMA standards.

#### Features

Features for typical non-linear load service include:

- Three-phase, dry type transformers, 480 Delta – 208Y/120
- Electrostatic shield
- Class 220 installation
- Reduced core flux to compensate for harmonic voltage distortion
- 200% neutral with double size neutral terminal for additional customer neutral cables
- Additional coil capacity to compensate for higher non-linear load loss
- Temperature rise of 115°C
- Heavy-gauge ventilated indoor enclosures (weather shields available)
- UL Listed

#### Three Phase Standard NL Model 60 Hz

kVA	Catalog Number	Full Capacity Taps	Deg. C. Temp. Rise	Wt. (lbs)	Encl. ■	Wiring ♦
<b>480 Volts Delta Primary 208Y/120 Volts Secondary 60 Hz</b>			<b>Aluminum Wound UL K-4 Rated</b>			
15	<b>15T3HFISNL</b>	6—2.5%2+4-	115	240	17D	10
30	<b>30T3HFISNL</b>	6—2.5%2+4-	115	300	18D	10
45	<b>45T3HFISNL</b>	6—2.5%2+4-	115	500	19D	10
75	<b>75T3HFISNL</b>	6—2.5%2+4-	115	725	21D	10
112.5	<b>112T3HFISNL</b>	6—2.5%2+4-	115	950	22D	10
150	<b>150T3HFISNL</b>	6—2.5%2+4-	115	1290	24D	10
225	225T3HFISNL	6—2.5%2+4-	115	1900	25D	10
300	300T68HFISNL	4—2.5%2+2-	115	2100	25D	11
500	500T90HFISNL	4—3.5%2+2-	115	3600	29D	11
<b>480 Volts Delta Primary 208Y/120 Volts Secondary 60 Hz</b>			<b>Copper Wound UL K-4 Rated</b>			
15	15T3HFISCUNL	6—2.5%2+4-	115	330	18D	10
30	<b>30T3HFISCUNL</b>	6—2.5%2+4-	115	380	18D	10
45	<b>45T3HFISCUNL</b>	6—2.5%2+4-	115	475	18D	10
75	<b>75T3HFISCUNL</b>	6—2.5%2+4-	115	865	21D	10
112.5	112T3HFISCUNL	6—2.5%2+4-	115	1090	22D	10
150	150T3HFISCUNL	6—2.5%2+4-	115	1450	24D	10
225	225T3HFISCUNL	6—2.5%2+4-	115	2065	25D	10
300	300T68HFISCUNL	4—2.5%2+2-	115	2200	25D	11
500	500T90HFISCUNL	4—3.5%2+2-	115	4300	29D	11

**Note:** Boldface Catalog Numbers indicate in-stock transformers.  
 ■ For enclosure styles see **Dimensions Table** Page 27.  
 ♦ See **Wiring Diagrams** Page 41.



Type NL Transformers for typical non-linear load service and Type NLP Transformers for more severe non-linear load service.

#### Three Phase Premium NLP Model

kVA	Catalog Number	Full Capacity Taps	Deg. C. Temp. Rise	Wt. (lbs)	Encl. ■	Wiring ♦
<b>480 Volts Delta Primary 208Y/120 Volts Secondary 60 Hz</b>			<b>Aluminum Wound UL K-13 Rated</b>			
15	<b>15T3HFISNLP</b>	6—2.5%2+4-	115	245	17D	10
30	<b>30T3HFISNLP</b>	6—2.5%2+4-	115	350	18D	10
45	<b>45T3HFISNLP</b>	6—2.5%2+4-	115	600	19D	10
75	<b>75T3HFISNLP</b>	6—2.5%2+4-	115	780	22D	10
112.5	<b>112T3HFISNLP</b>	6—2.5%2+4-	115	1025	22D	10
150	<b>150T3HFISNLP</b>	6—2.5%2+4-	115	1390	25D	10
225	<b>225T3HFISNLP</b>	6—2.5%2+4-	115	2010	25D	10
300	300T68HFISNLP	4—2.5%2+2-	115	2100	30D	11
500	500T90HFISNLP	4—3.5%2+2-	115	3600	32F	11
<b>480 Volts Delta Primary 208Y/120 Volts Secondary 60 Hz</b>			<b>Copper Wound UL K-13 Rated</b>			
15	15T3HFISCUNLP	6—2.5%2+4-	115	330	18D	10
30	<b>30T3HFISCUNLP</b>	6—2.5%2+4-	115	380	18D	10
45	<b>45T3HFISCUNLP</b>	6—2.5%2+4-	115	600	19D	10
75	<b>75T3HFISCUNLP</b>	6—2.5%2+4-	115	865	22D	10
112.5	<b>112T3HFISCUNLP</b>	6—2.5%2+4-	115	1250	22D	10
150	150T3HFISCUNLP	6—2.5%2+4-	115	1955	25D	10
225	225T3HFISCUNLP	6—2.5%2+4-	115	2450	25D	10
300	300T68HFISCUNLP	4—2.5%2+2-	115	2400	30D	11
500	500T90HFISCUNLP	4—3.5%2+2-	115	5000	33F	11



# Special Purpose Transformers

## Shielded Isolation Transformers



Typical Shielded Isolation Transformer

### How to Order Single Phase

Select the voltage required from the chart below and insert the voltage code in place of the parentheses ( ) in the catalog number.

Voltage Code	Primary	Secondary	Wiring♦
6	120x240	120/240	1
7	208	120/240	6
8	277	120/240	6
9	208	208	7

### Single Phase

kVA	Catalog Number	Full Capacity Taps	Deg. C. Temp. Rise	Wt. (lbs)	Encl. ■
<b>480 Volts Primary</b>					
<b>120/240 Volts Secondary (with Electrostatic Shield) 60 Hz</b>					
1	1S( )FIS	None	115	21.2	7A
1.5	1.5S( )FIS	None	115	30.1	8A
2	2S( )FIS	None	115	39.1	9A
3	3S( )FIS	None	115	55.2	10A
5	5S( )FIS	None	115	115	13B
7.5	7S( )FIS	None	115	150	13B
10	10S( )FIS	None	115	165	13B
15	15S( )HIS	None	150	200	17D
25	25S( )HIS	None	150	230	17D

**Note:** Boldface Catalog Numbers indicate in-stock transformers. Single phase stocked in voltage codes 6 and 7, from 1 through 25kVA.

★ (FCBN) Full Capacity Taps Below Normal where noted.

■ For enclosure styles see **Dimensions Table** Page 27.

♦ See **Wiring Diagrams** Page 41.

### Application

Although any transformer with two windings is an “isolating” transformer, because the internal primary winding is isolated and insulated from the secondary winding, isolation transformers have a special function. They isolate electrical power from the normal **supply source** to reduce the effect of power surges. For example, applications such as electronic motor controls, X-ray machines, and computers benefit from the use of shielded isolation transformers.

### Accessories

- **Electrostatic shields** — Isolation transformers can be equipped with electrostatic shields between the primary and secondary to reduce line interference or undesirable frequencies; critical equipment may require this added protection. An electrostatic shield is indicated by “IS” at the end of the catalog number, such as 3S6FIS.
- **Filters** — Primary surge suppression and secondary filters can be added to shielded isolation transformers for additional reduction of transient and across-the-line surges. Surge suppression and filters are indicated by “FIL” at the end of the catalog number, such as 15T3HISFIL.

### Three Phase

kVA	Catalog Number	Full Capacity Taps★	Deg. C. Temp. Rise	Wt. (lbs)	Encl. ■	Wiring ♦
<b>480 Volts Delta Primary</b>						
<b>208Y/120 Volts Secondary (With Electrostatic Shield) 60 Hz</b>						
9	<b>9T2FIS</b>	2—5%FCBN	115	265	14C	8
15	<b>15T3HIS</b>	6—2.5%2+4-	150	200	17D	10
30	<b>30T3HIS</b>	6—2.5%2+4-	150	250	17D	10
45	<b>45T3HIS</b>	6—2.5%2+4-	150	340	18D	10
75	<b>75T3HIS</b>	6—2.5%2+4-	150	500	19D	10
112.5	<b>112T3HIS</b>	6—2.5%2+4-	150	750	21D	10
150	<b>150T3HIS</b>	6—2.5%2+4-	150	1020	22D	10
225	<b>225T3HIS</b>	6—2.5%2+4-	150	1275	24D	10
300	<b>300T3HIS</b>	6—2.5%2+4-	150	1680	25D	10
500	500T68HIS	4—2.5%2+2-	150	2460	30D	11
<b>208 Volts Delta Primary</b>						
<b>208Y/120 Volts Secondary (With Electrostatic Shield) 60 Hz</b>						
9	<b>9T85FIS</b>	2—5%FCBN	115	265	14C	8
15	<b>15T85HIS</b>	2—5%FCBN	150	200	17D	16
30	<b>30T85HIS</b>	2—5%FCBN	150	250	17D	16
45	<b>45T85HIS</b>	2—5%FCBN	150	340	18D	16
75	<b>75T85HIS</b>	2—5%FCBN	150	500	19D	16
112.5	112T85HIS	2—5%FCBN	150	750	21D	16
150	150T85HIS	2—5%FCBN	150	1020	22D	16
225	225T85HIS	2—5%FCBN	150	1275	24D	16
300	300T85HIS	2—5%FCBN	150	1680	25D	16
500	500T85HIS	2—5%FCBN	150	2460	30D	16



Special Purpose Transformers  
**Isolation Transformers**  
**Shielded and Filtered**



Typical Shielded Isolation Transformer With Filter

**Three Phase**

kVA	Catalog Number	Full Capacity Taps★	Deg. C. Temp. Rise	Wt. (lbs)	Encl. ■	Wiring ♦
<b>480 Volts Delta Primary</b>						
<b>208Y/120 Volts Secondary (With Shield and Filter) 60 Hz</b>						
15	15T85HISFIL	2—5%FCBN	150	265	19D	16
30	30T85HISFIL	2—5%FCBN	150	330	19D	16
45	45T85HISFIL	2—5%FCBN	150	390	19D	16
75	75T85HISFIL	2—5%FCBN	150	525	21D	16
112.5	112T85HISFIL	2—5%FCBN	150	840	22D	16
150	150T85HISFIL	2—5%FCBN	150	1125	25D	16
225	225T85HISFIL	2—5%FCBN	150	1365	26D	16

**Three Phase**

kVA	Catalog Number	Full Capacity Taps	Deg. C. Temp. Rise	Wt. (lbs)	Encl. ■	Wiring ♦
<b>480 Volts Delta Primary</b>						
<b>208Y/120 Volts Secondary (With Shield and Filter) 60 Hz</b>						
15	<b>15T3HISFIL</b>	6—2.5%2+4-	150	265	19D	10
30	<b>30T3HISFIL</b>	6—2.5%2+4-	150	330	19D	10
45	<b>45T3HISFIL</b>	6—2.5%2+4-	150	390	19D	10
75	<b>75T3HISFIL</b>	6—2.5%2+4-	150	525	21D	10
112.5	112T3HISFIL	6—2.5%2+4-	150	840	22D	10
150	150T3HISFIL	6—2.5%2+4-	150	1125	25D	10
225	225T3HISFIL	6—2.5%2+4-	150	1365	26D	10

**Note:** Boldface Catalog Numbers indicate in-stock transformers.  
 ★ (FCBN) Full Capacity Taps Below Normal where noted.  
 ■ For enclosure styles see **Dimensions Table** Page 27.  
 ♦ See **Wiring Diagrams** Page 41.



## Special Purpose Transformers

### Buck and Boost Transformers



**Buck & Boost Transformer**

#### Application

Buck and Boost transformers are isolating transformers that have 120 x 240 volt primaries and either 12/24 or 16/32 volt secondaries. When used as isolating transformers, they carry the full load stated on the nameplate. However, their primary use and value is that the primary and secondary can be interconnected for use as an autotransformer. When used as an autotransformer to slightly step up or down voltage, the Buck and Boost transformer can carry loads in excess of its nameplate rating. Using the transformer in this way is one of the most economical and compact means of slightly adjusting voltage.

#### How to Make a Selection

Refer to the Tables 1–10 that follow for guidelines in selecting the correct transformer that supplies the required voltage for a specific kVA load.

**Single Phase Loads** – If load voltages of 115V, 120V, 230V or 240V are required, refer to Tables 1, 2, 3 or 4 respectively.

**Three Phase Loads** – (For power or lighting, but available voltage must be a 3-phase, 4-wire system with neutral for lighting.) If load voltages of 230V, 240V, 460V or 480V are required, refer to Tables 5, 6, 7 or 8 respectively.

**Three Phase Loads** – (Open delta connection for 3-wire power loads only. Requires only 3-phase, 3-wire available voltage.) If load voltages of 230V or 240V are required, refer to Tables 9 or 10 respectively.

To use Tables 1–10 in this section, do the following:

1. Calculate LOAD kVA:

$$\text{Single Phase kVA} = \frac{\text{Load Volts} \times \text{Load Amperes}}{1000}$$

$$\text{Three Phase kVA} = \frac{\text{Load Volts} \times \text{Load Amperes} \times 1.73}{1000}$$

2. Select the **Desired Load Voltage** table nearest the voltage required.
3. Check for the nearest **Available Voltage** to the actual voltage measured.
4. Follow down the vertical column of the voltage measured and select a load kVA value **equal to or greater than** calculated (*never smaller*), then move horizontally to the left and select the transformer catalog number.

**Note:** For 3-phase loads, two or three transformers may be required as shown in the table heading.

5. Refer to the correct wiring diagram number at the bottom of the “Load kVA” column for the load kVA you have chosen.

#### Common “Mis-Applications”

Using Buck and Boost transformers incorrectly can be avoided by observing both common sense and the restrictions for autotransformers in the National Electrical Code. The following are some examples of incorrect use.

- Creating a 240/120 single phase service from 208Y/120 source. This creates unbalanced line-to-line neutral voltages. This application is proper only for 240V 2-wire loads.

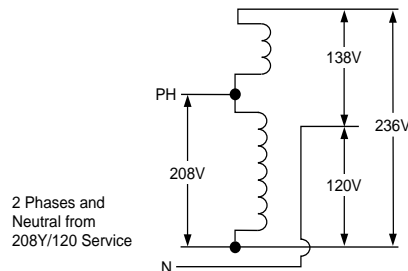

- Bucking or boosting 3-phase, 3-wire systems for 3-phase, 4-wire loads.

This uses three Buck and Boost transformers in a 3-phase wye connection. The neutral created by this connection is not stable and will not yield proper line-to-neutral voltages under load. This connection violates NEC Article 210-9, Exception No.1. The wye connection can be used for 3-wire to 3-wire, 4-wire to 3-wire, and 4-wire to 4-wire applications.

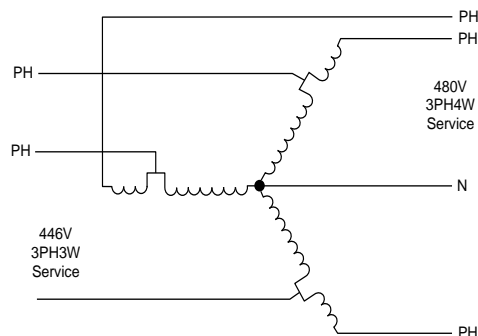

- Correcting long-line voltage drop where load fluctuates. Line drop will vary with load. If Buck and Boost transformers are used to correct voltage drop during peak load cycle, dangerously high voltages may result under lightly loaded conditions.

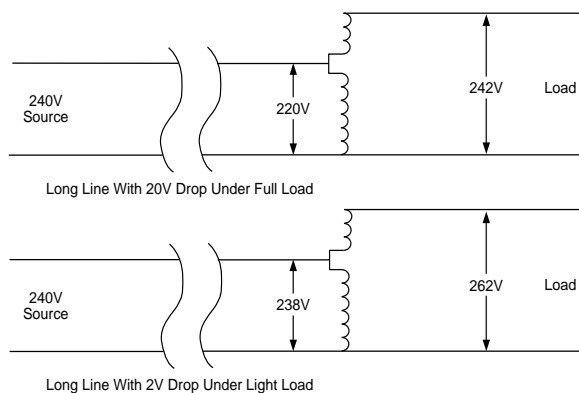

# Special Purpose Transformers

## Buck and Boost Transformers

### Single Phase

**Table 1: Desired Load Voltage: 115V      Single Phase, 60 Hz      One Transformer Required**

Transformer Catalog Numbers	Available Voltage							
	91	96	101	105	127	130	138	146
	Single Phase Load kVA							
50SV43A	—	0.25	—	0.5	0.5	—	0.25	—
50SV46A	0.18	—	0.37	—	—	0.37	—	0.18
100SV43A	—	0.5	—	1	1	—	0.5	—
100SV46A	0.37	—	0.75	—	—	0.75	—	0.37
150SV43A	—	0.75	—	1.5	1.5	—	0.75	—
150SV46A	0.56	—	1.12	—	—	1.12	—	0.56
250SV43B	—	1.25	—	2.5	2.5	—	1.25	—
250SV46B	0.94	—	1.88	—	—	1.88	—	0.94
500SV43B	—	2.5	—	5	5	—	2.5	—
500SV46B	1.88	—	3.75	—	—	3.75	—	1.88
750SV43F	—	3.75	—	7.5	7.5	—	3.75	—
750SV46F	2.81	—	5.62	—	—	5.62	—	2.81
1S43F	—	5	—	10	10	—	5	—
1S46F	3.75	—	7.5	—	—	7.5	—	3.75
1.5S43F	—	7.5	—	15	15	—	7.5	—
1.5S46F	5.62	—	11.25	—	—	11.25	—	5.62
2S43F	—	10	—	20	20	—	10	—
2S46F	7.5	—	15	—	—	15	—	7.5
3S43F	—	15	—	30	30	—	15	—
3S46F	11.25	—	22.5	—	—	22.5	—	11.25
Wiring Diagram	2	2	1	1	1	1	2	2

**Table 2: Desired Load Voltage: 120V      Single Phase, 60 Hz      One Transformer Required**

Transformer Catalog Numbers	Available Voltage							
	95	100	106	109	132	136	144	152
	Single Phase Load kVA							
50SV43A	—	0.25	—	0.5	0.5	—	0.25	—
50SV46A	0.18	—	0.37	—	—	0.37	—	0.18
100SV43A	—	0.5	—	1	1	—	0.5	—
100SV46A	0.37	—	0.75	—	—	0.75	—	0.37
150SV43A	—	0.75	—	1.5	1.5	—	0.75	—
150SV46A	0.56	—	1.12	—	—	1.12	—	0.56
250SV43B	—	1.25	—	2.5	2.5	—	1.25	—
250SV46B	0.94	—	1.88	—	—	1.88	—	0.94
500SV43B	—	2.5	—	5	5	—	2.5	—
500SV46B	1.88	—	3.75	—	—	3.75	—	1.88
750SV43F	—	3.75	—	7.5	7.5	—	3.75	—
750SV46F	2.81	—	5.62	—	—	5.62	—	2.81
1S43F	—	5	—	10	10	—	5	—
1S46F	3.75	—	7.5	—	—	7.5	—	3.75
1.5S43F	—	7.5	—	15	15	—	7.5	—
1.5S46F	5.62	—	11.25	—	—	11.25	—	5.62
2S43F	—	10	—	20	20	—	10	—
2S46F	7.5	—	15	—	—	15	—	7.5
3S43F	—	15	—	30	30	—	15	—
3S46F	11.25	—	22.5	—	—	22.5	—	11.25
Wiring Diagram	2	2	1	1	1	1	2	2

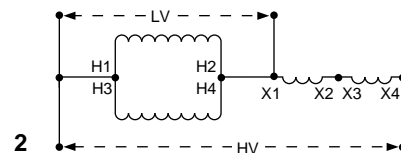
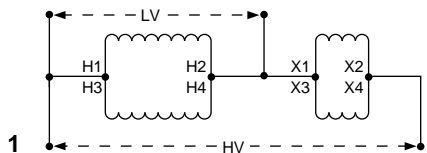

# Special Purpose Transformers

## Buck and Boost Transformers

### Single Phase

**Table 3: Desired Load Voltage: 230V Single Phase, 60 Hz One Transformer Required**

Transformer Catalog Numbers	Available Voltage							
	203	208	216	219	242	245	253	261
	Single Phase Load kVA							
50SV43A	—	0.5	—	1	1	—	0.5	—
50SV46A	0.37	—	0.75	—	—	0.75	—	0.37
100SV43A	—	1	—	2	2	—	1	—
100SV46A	0.75	—	1.5	—	—	1.5	—	0.75
150SV43A	—	1.5	—	3	3	—	1.5	—
150SV46A	1.12	—	2.25	—	—	2.25	—	1.12
250SV43B	—	2.5	—	5	5	—	2.5	—
250SV46B	1.88	—	3.75	—	—	3.75	—	1.88
500SV43B	—	5	—	10	10	—	5	—
500SV46B	3.75	—	7.5	—	—	7.5	—	3.75
750SV43F	—	7.5	—	15	15	—	7.5	—
750SV46F	5.62	—	11.25	—	—	11.25	—	5.62
1S43F	—	10	—	20	20	—	10	—
1S46F	7.5	—	15	—	—	15	—	7.5
1.5S43F	—	15	—	30	30	—	15	—
1.5S46F	11.25	—	22.5	—	—	22.5	—	11.25
2S43F	—	20	—	40	40	—	20	—
2S46F	15	—	30	—	—	30	—	15
3S43F	—	30	—	60	60	—	30	—
3S46F	22.5	—	45	—	—	45	—	22.5
Wiring Diagram	4	4	3	3	3	3	4	4

**Table 4: Desired Load Voltage: 240V Single Phase, 60 Hz One Transformer Required**

Transformer Catalog Numbers	Available Voltage							
	212	218	225	229	252	256	264	272
	Single Phase Load kVA							
50SV43A	—	0.5	—	1	1	—	0.5	—
50SV46A	0.37	—	0.75	—	—	0.75	—	0.37
100SV43A	—	1	—	2	2	—	1	—
100SV46A	0.75	—	1.5	—	—	1.5	—	0.75
150SV43A	—	1.5	—	3	3	—	1.5	—
150SV46A	1.12	—	2.25	—	—	2.25	—	1.12
250SV43B	—	2.5	—	5	5	—	2.5	—
250SV46B	1.88	—	3.75	—	—	3.75	—	1.88
500SV43B	—	5	—	10	10	—	5	—
500SV46B	3.75	—	7.5	—	—	7.5	—	3.75
750SV43F	—	7.5	—	15	15	—	7.5	—
750SV46F	5.62	—	11.25	—	—	11.25	—	5.62
1S43F	—	10	—	20	20	—	10	—
1S46F	7.5	—	15	—	—	15	—	7.5
1.5S43F	—	15	—	30	30	—	15	—
1.5S46F	11.25	—	22.5	—	—	22.5	—	11.25
2S43F	—	20	—	40	40	—	20	—
2S46F	15	—	30	—	—	30	—	15
3S43F	—	30	—	60	60	—	30	—
3S46F	22.5	—	45	—	—	45	—	22.5
Wiring Diagram	4	4	3	3	3	3	4	4

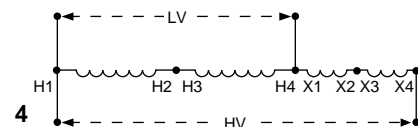
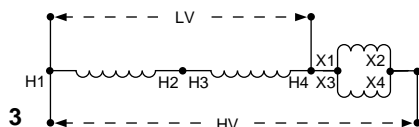



# Special Purpose Transformers

## Buck and Boost Transformers

### Three Phase

**Table 5: Desired Load Voltage: 230Y/133 Three Phase, 60 Hz, Three Transformers Required**

Transformer Catalog Numbers	Available Voltage			
	181Y/105	192Y/111	203Y/117	208Y/120
Three Phase Load kVA				
50SV43A	—	0.75	—	1.5
50SV46A	0.56	—	1.12	—
100SV43A	—	1.5	—	3
100SV46A	1.12	—	2.25	—
150SV43A	—	2.25	—	4.5
<hr/>				
150SV46A	1.69	—	3.38	—
250SV43B	—	3.75	—	7.5
250SV46B	2.81	—	5.62	—
500SV43B	—	7.5	—	15
500SV46B	5.62	—	11.25	—
<hr/>				
750SV43F	—	11.25	—	22.5
750SV46F	8.45	—	16.9	—
1S43F	—	15	—	30
1S46F	11.25	—	22.5	—
1.5S43F	—	22.5	—	45
<hr/>				
1.5S46F	16.9	—	33.8	—
2S43F	—	30	—	60
2S46F	22.5	—	45	—
3S43F	—	45	—	90
3S46F	33.8	—	67.6	—
<hr/>				
Wiring Diagram	8	8	7	7

**Table 7: Desired Load Voltage: 460Y/265 Three Phase, 60 Hz, Three Transformers Required**

Transformer Catalog Numbers	Available Voltage			
	406Y/235	418Y/242	432Y/250	438Y/253
Three Phase Load kVA				
50SV43A	—	1.5	—	3
50SV46A	1.12	—	2.25	—
100SV43A	—	3	—	6
100SV46A	2.25	—	4.5	—
150SV43A	—	4.5	—	9
<hr/>				
150SV46A	3.38	—	6.76	—
250SV43B	—	7.5	—	15
250SV46B	5.62	—	11.25	—
500SV43B	—	15	—	30
500SV46B	11.25	—	22.5	—
<hr/>				
750SV43F	—	22.5	—	45
750SV46F	16.9	—	33.8	—
1S43F	—	30	—	60
1S46F	22.5	—	45	—
1.5S43F	—	45	—	90
<hr/>				
1.5S46F	33.8	—	67.6	—
2S43F	—	60	—	120
2S46F	45	—	90	—
3S43F	—	90	—	180
3S46F	67.6	—	135	—
<hr/>				
Wiring Diagram	10	10	9	9

**Table 6: Desired Load Voltage: 240Y/138 Three Phase, 60 Hz, Three Transformers Required**

Transformer Catalog Numbers	Available Voltage			
	189Y/109	200Y/115	212Y/122	218Y/126
Three Phase Load kVA				
50SV43A	—	0.75	—	1.5
50SV46A	0.56	—	1.12	—
100SV43A	—	1.5	—	3
100SV46A	1.12	—	2.25	—
150SV43A	—	2.25	—	4.5
<hr/>				
150SV46A	1.69	—	3.38	—
250SV43B	—	3.75	—	7.5
250SV46B	2.81	—	5.62	—
500SV43B	—	7.5	—	15
500SV46B	5.62	—	11.25	—
<hr/>				
750SV43F	—	11.25	—	22.5
750SV46F	8.45	—	16.9	—
1S43F	—	15	—	30
1S46F	11.25	—	22.5	—
1.5S43F	—	22.5	—	45
<hr/>				
1.5S46F	16.9	—	33.8	—
2S43F	—	30	—	60
2S46F	22.5	—	45	—
3S43F	—	45	—	90
3S46F	33.8	—	67.6	—
<hr/>				
Wiring Diagram	8	8	7	7

**Table 8: Desired Load Voltage: 480Y/277 Three Phase, 60 Hz, Three Transformers Required**

Transformer Catalog Numbers	Available Voltage			
	424Y/245	436Y/252	450Y/260	457Y/264
Three Phase Load kVA				
50SV43A	—	1.5	—	3
50SV46A	1.12	—	2.25	—
100SV43A	—	3	—	6
100SV46A	2.25	—	4.5	—
150SV43A	—	4.5	—	9
<hr/>				
150SV46A	3.38	—	6.76	—
250SV43B	—	7.5	—	15
250SV46B	5.62	—	11.25	—
500SV43B	—	15	—	30
500SV46B	11.25	—	22.5	—
<hr/>				
750SV43F	—	22.5	—	45
750SV46F	16.9	—	33.8	—
1S43F	—	30	—	60
1S46F	22.5	—	45	—
1.5S43F	—	45	—	90
<hr/>				
1.5S46F	33.8	—	67.6	—
2S43F	—	60	—	120
2S46F	45	—	90	—
3S43F	—	90	—	180
3S46F	67.6	—	135	—
<hr/>				
Wiring Diagram	10	10	9	9

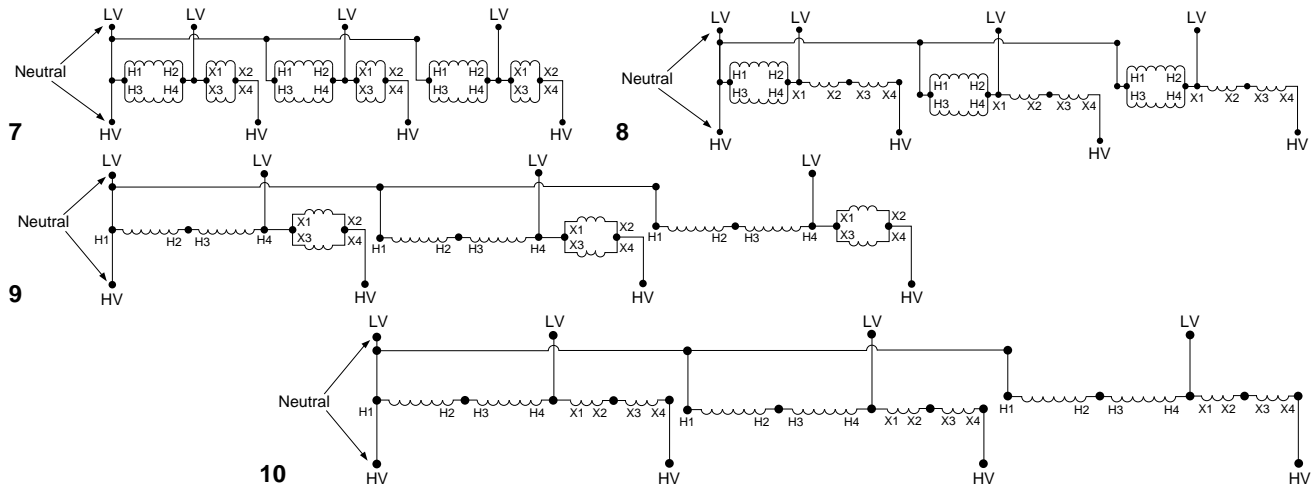

# Special Purpose Transformers

## Buck and Boost Transformers

### Three Phase

**Table 9: Desired Load Voltage: 230V, Three Phase, 60 Hz,  
(Open Delta-Power Loads Only) Two Transformers Required**

Transformer Catalog Numbers	Available Voltage							
	203	209	216	219	242	245	253	260
	Three Phase Load kVA							
50SV43A	—	0.86	—	—	—	—	0.86	—
50SV46A	0.64	—	1.29	1.72	1.72	1.29	—	0.64
100SV43A	—	1.72	—	3.43	3.43	—	1.72	—
100SV46A	1.29	—	2.58	—	—	2.58	—	1.29
150SV43A	—	2.58	—	5.16	5.16	—	2.58	—
150SV46A	1.94	—	3.88	—	—	3.38	—	1.94
250SV43B	—	4.3	—	8.6	8.6	—	4.3	—
250SV46B	3.23	—	6.45	—	—	6.45	—	3.23
500SV43B	—	8.6	—	17.2	17.2	—	8.6	—
500SV46B	6.45	—	12.9	—	—	12.9	—	6.45
750SV43F	—	12.9	—	25.8	25.8	—	12.9	—
750SV46F	9.7	—	19.4	—	—	19.4	—	9.7
1S43F	—	17.2	—	34.3	34.3	—	17.2	—
1S46F	12.9	—	25.8	—	—	25.8	—	12.9
1.5S43F	—	25.8	—	51.6	51.6	—	25.8	—
1.5S46F	19.4	—	38.8	—	—	38.8	—	19.4
2S43F	—	34.3	—	68.8	68.8	—	34.3	—
2S46F	25.8	—	51.6	—	—	51.6	—	25.8
3S43F	—	51.6	—	103.2	103.2	—	51.6	—
3S46F	38.8	—	77.6	—	—	77.6	—	38.8
Wiring Diagram	6	6	5	5	5	5	6	6

**Table 10: Desired Load Voltage: 240V, Three Phase, 60 Hz,  
(Open Delta-Power Loads Only) Two Transformers Required**

Transformer Catalog Numbers	Available Voltage							
	212	218	225	229	252	256	264	272
	Three Phase Load kVA							
50SV43A	—	0.86	—	—	—	—	0.86	—
50SV46A	0.64	—	1.29	1.72	1.72	1.29	—	0.64
100SV43A	—	1.72	—	3.43	3.43	—	1.72	—
100SV46A	1.29	—	2.58	—	—	2.58	—	1.29
150SV43A	—	2.58	—	5.16	5.16	—	2.58	—
150SV46A	1.94	—	3.88	—	—	3.38	—	1.94
250SV43B	—	4.3	—	8.6	8.6	—	4.3	—
250SV46B	3.23	—	6.45	—	—	6.45	—	3.23
500SV43B	—	8.6	—	17.2	17.2	—	8.6	—
500SV46B	6.45	—	12.9	—	—	12.9	—	6.45
750SV43F	—	12.9	—	25.8	25.8	—	12.9	—
750SV46F	9.7	—	19.4	—	—	19.4	—	9.7
1S43F	—	17.2	—	34.3	34.3	—	17.2	—
1S46F	12.9	—	25.8	—	—	25.8	—	12.9
1.5S43F	—	25.8	—	51.6	51.6	—	25.8	—
1.5S46F	19.4	—	38.8	—	—	38.8	—	19.4
2S43F	—	34.3	—	68.8	68.8	—	34.3	—
2S46F	25.8	—	51.6	—	—	51.6	—	25.8
3S43F	—	51.6	—	103.2	103.2	—	51.6	—
3S46F	38.8	—	77.6	—	—	77.6	—	38.8
Wiring Diagram	6	6	5	5	5	5	6	6

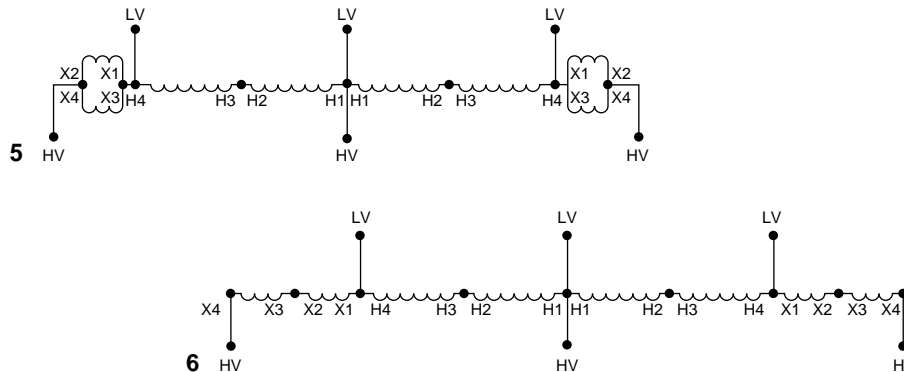

# Special Purpose Transformers

## MINI POWER-ZONE® Power Supply



MINI POWER-ZONE Power Supply

**480 Volts Primary** **Single Phase**  
**120/240 Volts Secondary 60 Hz**

kVA	Catalog Number	Dimensions					
		Height		Width		Depth	
		IN	mm	IN	mm	IN	mm
5	<b>MPZ5S40F</b>	32.7	831	12.0	305	11.9	303
7.5	<b>MPZ7S40F</b>	32.7	831	12.0	305	11.9	303
10	<b>MPZ10S40F</b>	32.7	831	12.0	305	11.9	303
15	<b>MPZ15S40F</b>	42.9	1090	17.4	442	13.5	343
25	<b>MPZ25S40F</b>	42.9	1090	17.4	442	13.5	343

**480 Volts Delta Primary** **Three Phase**  
**208Y/120 Volts Secondary 60 Hz**

15	<b>MPZ15T2F</b>	44.6	1133	27.4	696	13.6	345
22.5	<b>MPZ22T2F</b>	44.6	1133	27.4	696	13.6	345
30	<b>MPZ30T2F</b>	44.6	1133	27.4	696	13.6	345

### Single Phase

**480 Volts Primary**  
**120/240 Volts Secondary 60 Hz**

kVA	Catalog Number	Wt. Lbs.	Primary Main Circuit Breaker	Feeder Breakers			
				Secondary Main Circuit Breaker	Max. No. 1 Pole or 2 Pole	Max. Amperes	
5	<b>MPZ5S40F</b>	175	FAL24020 20A	QO-230 30A	6 or 3	20	
7.5	<b>MPZ7S40F</b>	200	FAL24030 30A	QO-240 40A	8 or 4	30	
10	<b>MPZ10S40F</b>	215	FAL24040 40A	QO-260 60A	10 or 5	40	
15	<b>MPZ15S40F</b>	350	FAL24060 60A	QO-280 80A	16 or 8	60	
25	<b>MPZ25S40F</b>	425	FAL24100 100A	QO-2125 125A	24 or 12	100	

### Three Phase

**480 Volts Delta Primary**  
**208Y/120 Volts Secondary 60 Hz**

kVA	Catalog Number	Wt. Lbs.	Primary Main Circuit Breaker	Feeder Breakers			
				Secondary Main Circuit Breaker	Max. No. 1 Pole or 2 pole	Max. Amperes	
15	<b>MPZ15T2F</b>	710	FAL34040 40A	QO-360 60A	12 or 4	40	
22.5	<b>MPZ22T2F</b>	725	FAL34070 70A	QO-380 80A	18 or 6	60	
30	<b>MPZ30T2F</b>	755	FAL34090 90A	QO-3100 100A	24 or 8	80	

**Note:** Boldface Catalog Numbers indicate in-stock transformers.

### Application

The MINI POWER-ZONE® packaged power supply is the low voltage (600 volts and below) version of our POWER-ZONE® package unit substation. The MINI POWER-ZONE provides a compact power supply for small loads and is suitable for service equipment. This unit is a space-saving substitute for an individual main breaker, transformer, and secondary distribution panel that are connected via conduit. Proper coordination of primary breaker and transformer is assured to prevent nuisance tripping on power-on inrush. The MINI POWER-ZONE power supply is UL Listed for both indoor and outdoor use.

### Features

The MINI POWER-ZONE package includes these features:

- A transformer with a maximum full load temperature rise of 115°C using a 180°C insulation system. The core and coil is encapsulated in an epoxy resin-sand combination.
- A circuit breaker section enclosed in a weather-resistant, steel enclosure.
- Enclosures use an electrostatically applied, ANSI 49 color, powder coating to protect both the transformer and panel board section and to provide extra corrosion resistance. This construction provides an exceptionally durable unit for use in wet, dirty, or dusty applications.
- Unique two-part construction uses removable transformers that can be replaced without disturbing external panelboard wiring. All sizes are furnished from Square D warehouse stock, complete with the transformer main primary and main secondary circuit breakers sized in accordance with National Electrical Code requirements.
- Accommodates standard Square D plug-on branch circuit breakers and QUIK-GARD® ground fault circuit breakers.
- Shunt trip capability on the primary breaker is available by special order if local code requires remote tripping when the package is used as service equipment.
- Electrostatic shield and bolt-on panel are available by special order.



# Special Purpose Transformers

## Drive Isolation Transformers



Drive Isolation Transformer

### How to Order

To complete the catalog number, select the voltage required from the chart and insert the voltage code in place of the parentheses ( ) in the catalog number.

Voltage Code	Primary	Secondary
142	230 Delta	230Y/132
143	230 Delta	460Y/265
144	460 Delta	230Y/132
145	460 Delta	460Y/265
146	575 Delta	230Y/132
147	575 Delta	460Y/265

### Application

Square D drive isolation transformers are designed for the special requirements of ac and dc motor drives, and allow for high-surge, harmonic, and offset currents. *Drive isolation transformers* should not be confused with *isolation transformers* (see Page 17). Drive isolation transformers reduce transient generation into a supply power and buffer SCR current surges.

The main function of drive isolation transformers is to provide the following:

- **Voltage Change** — if necessary, these units adjust the voltage to match the motor drive voltage requirements.
- **Isolated Secondary Winding** — normally the secondary is grounded to a new isolated building ground to provide greater insurance against drive “noise” coupling back into the primary system and affecting other equipment on the same service.
- **Reactive Buffer** — tends to ease the rate of current change in the solid-state switching elements contained in the drive.

### Features

- Evaluated according to UL Standard 1561 for effects of harmonic heating.
- Designed for typical harmonics per IEEE 519-1992.
- Meets 4% minimum reactance for 150°C temperature rise designs.
- Conforms to IEEE-597 Class B overload, which requires 150% of load for one minute per hour.
- Designed for the mechanical stress of dc drive current spikes.
- Designed for the thermal and mechanical stress of highly-cyclic process control applications.

### Three Phase 60 Hz

kVA	Catalog Number	Full Capacity Taps	Deg. C. Temp. Rise	Wt. (lbs.)	Encl. ■	Wiring ♦
7.5	7T( )HDIT	2—5%1+1-	150	180	17D	16
11	11T( )HDIT	2—5%1+1-	150	180	17D	16
15	15T( )HDIT	2—5%1+1-	150	190	17D	16
20	20T( )HDIT	2—5%1+1-	150	210	17D	16
27	27T( )HDIT	2—5%1+1-	150	250	17D	16
34	34T( )HDIT	2—5%1+1-	150	295	18D	16
40	40T( )HDIT	2—5%1+1-	150	350	18D	16
51	51T( )HDIT	2—5%1+1-	150	445	20D	16
63	63T( )HDIT	2—5%1+1-	150	465	20D	16
75	75T( )HDIT	2—5%1+1-	150	550	20D	16
93	93T( )HDIT	2—5%1+1-	150	845	22D	16
118	118T( )HDIT	2—5%1+1-	150	920	22D	16
145	145T( )HDIT	2—5%1+1-	150	1025	22D	16
175	175T( )HDIT	2—5%1+1-	150	1325	25D	16
220	220T( )HDIT	2—5%1+1-	150	1400	25D	16
275	275T( )HDIT	2—5%1+1-	150	1560	25D	16
330	300T( )HDIT	2—5%1+1-	150	1550	25D	16
440	440T( )HDIT	2—5%1+1-	150	1900	25D	16
550	550T( )HDIT	2—5%1+1-	150	2500	30D	16

**Note:** Transformers are in stock for voltage code 145 through 275kVA and voltage code 144 through 93kVA.

■ For enclosure styles see **Dimensions Table** Page 27.

♦ See **Wiring Diagrams** Page 41.



Accessories  
Lug Kits



Transformer Lug Kits

**VERSAtile® Compression Equipment Lugs – UL Listed**

Transformer kVA Size and Phase	Tool Type	Terminal Lugs		Hardware Included		Kit Catalog Number
		Qty.	Catalog Number	Qty.	Type	
15-37.5 1-Phase 15-45 3-Phase	VC6	8	VCEL-021-14S1	8	.25" x 1" Cap Screws	VCEL-SK1
		5	VCEL030-516H1	1	.25" x 2" Cap Screws	
50-75 1-Phase 75-112.5 3-Phase	VC6FT	13	VCEL030-516H1	8	.25" x 1" Cap Screws	VCEL-SK2
		8		8	.25" x 2" Cap Screws	
100-167 1-Phase 150-300 3-Phase	VC6FT	3	VCEL-030-516H1	3	.25" x .75" Cap Screws	VCEL-SK3
		26	VCEL-075-12H1	16	.37" x 2" Cap Screws	
100-167 1-Phase 150-300 3-Phase	VC6FT VC8	3	VCEL-030-516H1	3	.25" x 1" Cap Screws	VCEL-SK3-050
		26	VCEL-075-12H1	16	.37" x 2" Cap Screws	
500 3-Phase	VC6FT VC8	34	VCEL-075-12H1	21	.37" x 2" Cap Screws	VCEL-SK4

**Mechanical Set – Screw Type Lugs**

Transformer kVA Size	Terminal Lugs		Hardware Included		Kit Catalog Number
	Qty.	Catalog Number	Qty.	Type	
15-37.5 1-Phase 15-45 3-Phase	8	DA-2 DA-250	9	.25" x .75" Cap Screws	DA-SK1
50-75 1-Phase 75-112.5 3-Phase	13	DA-250	8	.25" x .75" Cap Screws .25" x 1.75" Cap Screws	DA-SK2
100-167 1-Phase 150-300 3-Phase	3	DA-250	3	.25" x .75" Cap Screws	DA-SK3
	26	DA600	16	.37" x 2" Cap Screws	
500 3-Phase	34	DA-600	21	.37" x 2" Cap Screws	DA-SK4



# Enclosures and Accessories

## Enclosure Dimensions and Accessories

**Table 1: Enclosure Dimensions and Accessories**

Enclosure Number/Style	Height		Width		Depth		Mounting	Weathershield	Wall Mounting Bracket	Ceiling Mounting Bracket	
	IN	mm	IN	mm	IN	mm					
1	A	5	127	4.47	114	3.44	87	Wall	—	—	
2	A	5.5	140	4.47	114	3.44	87	Wall	—	—	
3	A	5	127	4.85	123	3.75	95	Wall	—	—	
4	A	5.5	140	5.23	133	4.06	103	Wall	—	—	
5	A	6.19	157	6.19	157	4.69	119	Wall	—	—	
6	A	6.69	170	6.19	157	4.69	119	Wall	—	—	
7	A	8.13	270	6.94	176	5.31	135	Wall	—	—	
8	A	8.25	210	8.68	220	6.56	167	Wall	—	—	
9	A	9.56	243	8.68	220	6.56	167	Wall	—	—	
10	A	10.5	267	8.62	219	6.5	165	Wall	—	—	
11	A	12.56	319	8.62	219	6.5	165	Wall	—	—	
12	C	13.5	343	14.75	375	9	229	Wall	—	—	
13	B	14.75	375	9.75	248	11.75	298	Wall	—	—	
14	C	14.75	375	19.1	485	12.25	311	Wall	—	—	
15	B	20	508	15	381	13.5	343	Wall	—	—	
16	C	22	559	25	635	13.5	343	Wall	—	—	
17	D	27	686	20	508	16	406	Floor	WS363	WMB361–362	CMB363
	E	27	686	20	508	16	406	Floor	N/A	WMB361–362	CMB363
18	D	30	762	20	508	20	508	Floor	WS363	WMB363–364	CMB363
	E	30	762	20	508	20	508	Floor	N/A	WMB363–364	CMB363
19	D	30	762	30	762	20	508	Floor	WS364	WMB363–364	CMB364
	E	30	762	30	762	20	508	Floor	N/A	WMB363–364	CMB364
20	D	37	940	30	762	20	508	Floor	WS364	WMB363–364	CMB364
	E	37	940	30	762	20	508	Floor	N/A	WMB363–364	CMB364
21	D	37	940	30	762	24	610	Floor	WS364	N/A	CMB364
	E	37	940	30	762	24	610	Floor	N/A	N/A	CMB364
22	D	43.75	1111	32	813	27	686	Floor	WS380	N/A	CMB380
	E	43.75	1111	32	813	27	686	Floor	N/A	N/A	CMB380
23	D	48	1219	48	1219	29.5	749	Floor	WS368	N/A	N/A
	E	48	1219	48	1219	29.5	749	Floor	N/A	N/A	N/A
24	D	49.5	1257	35	889	28.5	724	Floor	WS381	N/A	CMB381
	E	49.5	1257	35	889	28.5	724	Floor	N/A	N/A	CMB381
25	D	49.5	1257	41	1041	32	813	Floor	WS382	N/A	N/A
	E	49.5	1257	41	1041	32	813	Floor	N/A	N/A	N/A
26	D	57.5	1461	41	1041	32	813	Floor	WS382	N/A	N/A
	E	57.5	1461	41	1041	32	813	Floor	N/A	N/A	N/A
27	D	58	1473	48	1219	29.5	749	Floor	WS368	N/A	N/A
	E	58	1473	48	1219	29.5	749	Floor	N/A	N/A	N/A
28	D	60	1524	56	1422	36	914	Floor	WS370A	N/A	N/A
	E	60	1524	56	1422	36	914	Floor	N/A	N/A	N/A
29	D	68	1727	56	1422	36	914	Floor	WS370A	N/A	N/A
	E	68	1727	56	1422	36	914	Floor	N/A	N/A	N/A
30	D	71	1803	48	1219	36	914	Floor	WS383	N/A	N/A
	E	71	1803	48	1219	36	914	Floor	N/A	N/A	N/A
31	D	74	1880	56	1422	40.5	1029	Floor	WS384	N/A	N/A
	E	74	1880	56	1422	40.5	1029	Floor	N/A	N/A	N/A
32	F	91.5	2324	56	1422	54	1372	Floor	N/A	N/A	N/A
33	F	91.5	2324	72	1829	54	1372	Floor	N/A	N/A	N/A
34	F	91.5	2324	84	2134	54	1372	Floor	N/A	N/A	N/A



Enclosures and Accessories  
**Enclosure Style and Accessories**



Enclosure Style A



Enclosure Style B



Enclosure Style C



Enclosure Style D



Enclosure Style E



Enclosure Style F



Transformer with Added Weathershield



### Application

Square D manufactures three lines of general purpose control power transformers, a high-efficiency line, a standard line, and an international line. All three lines are specifically designed to handle high inrush associated with contactors and relays for applications such as conveyor systems, paint lines, punch presses, or overhead cranes.

Type T and TF control power transformers, designed for international markets, are rated for 50/60 Hz. They are the best choice when size and cost are of concern for 50-1000 VA and when products need to meet the CE mark for international standards.

The Type T, like the Type K, also offers various temperature classes:

- 50-150 VA with a 55°C Temperature Rise
- 200-350 VA with a 80°C Temperature Rise
- 500-1000 VA with a 115°C Temperature Rise

Separate Fingersafe® accessory kits may be purchased and installed to meet EN60-742 for CE approval. The Type T and TF line meets requirements of UL, CSA, CE, and NOM. They are UL Listed under E61239, Guide XPTQ2, CSA certified under LR37055, Guide 184-N-90, CE marked under EN60742, and NOM117.

The standard line, Type K (1000-5000 VA) transformers, are the best choice if size and cost are of concern. These standard units use the most advanced insulating materials, making it possible to offer the advantages of different temperature classes:

- 50 VA- 250 VA with a 55°C Temperature Rise
- 300 VA- 350 VA with a 80°C Temperature Rise
- 500 VA - 5000 VA with a 115°C Temperature Rise

Type K control transformers are UL Listed under UL File No.E61239, Guide XPTQ2 and CSA certified under CSA File No. LR37055, Guide 184-N-90. The standard line includes Type KF designed with a top-mounted fuse block to accommodate two primary Class CC time delay fuses and one secondary 1.5" x 13/32" size fuse.

Type E control transformers are high-efficiency units with a 55°C temperature rise. This is the best choice when low heat contribution is required. These high-efficiency units provide extra regulation and lower energy losses. Type E control transformers are UL listed under File E61239 and also CSA certified under File No.LR37055, Guide 184-N-90.

All Square D control transformers are copper-wound, vacuum impregnated with varnish and fully tested in strict compliance with ANSI, CSA, and UL codes. Windings are additive polarity. Jumper cables are supplied with each transformer.

### Enhancements for Special Applications

The standard, high-efficiency, and international models all have designs adapted to meet the needs of special applications:

- **Top-mounted fuse block** —indicated as type KF, TF, or EOF.
- **Leads** — instead of terminal boards, are available on limited sizes. Indicated as type KL or EL.

- **Secondary fuse protection kits** — are available for 25-750 VA standard and 50-1000 VA for high efficiency. Indicated as type S if factory installed or AP if field installed.
- **Shorting bars** — for interconnecting terminals of dual-voltage transformers are included, extras available in separate kits. Indicated as type SB.
- **Special sizes and voltage combinations** are available.
- **Transformer kits** — for factory or field installation in combination starters. Indicated as type GO or GFT.

### Enhancements for Type T and TF Line Only

- **Fingersafe® Covers** — snap on to meet CE requirements (FSC-1 50-200 VA, FSC-2 250-1000 VA, and FSC-23 special 6 terminal applications)
- **Fuse Pullers Kit** — offers finger protection from fuse block for CE requirements and facilitates every fuse change out. (FP-1)
- **Secondary Fuse Protection Kits** — now available field-installable. Indicated as SF type.

### Regulation

Class 9070 transformers are designed with low impedance windings for excellence voltage regulation. This allows Class 9070 transformers to accommodate the high momentary inrush current caused when electromechanical devices such as contactors, relays and solenoids are energized. The secondary voltage drop between no load and momentary overload is low, helping to assure satisfactory operation of magnetic components.

### Selection Guide

1. Determine inrush and sealed VA of each coil in the control circuit.
2. Total the sealed VA of all coils.
3. Total the inrush VA of all coils at 100% secondary voltage. Add this value to the total sealed VA present (if any) when inrush occurs.
4. If the supply voltage is stable and varies no more than ±5%, refer to the 90% secondary voltage column. If the voltage varies as much as ±10%, use the 95% voltage column.
5. Using the regulation chart, select a transformer:
  - A. With a continuous VA rating equal to or greater than the value obtained in step 2
  - B. With a maximum inrush VA equal to or greater than the value obtained in step 3

### Regulation Chart — Inrush VA @ 30% Power Factor

VA	95% Secondary Voltage			90% Secondary Voltage			85% Secondary Voltage		
	Type E	Type K	Type T	Type E	Type K	Type T	Type E	Type K	Type T
25	72	N/A	161	109	N/A	221	131	N/A	281
50	171	161	161	235	221	221	299	281	281
75	327	244	244	390	337	337	554	437	437
100	382	307	307	553	440	440	722	575	575
150	468	521	521	735	765	765	997	1014	1014
200	1065	1065	759	1538	1538	1060	2163	2163	1369
250	1290	1290	1190	1949	1949	1660	2680	2680	2120
300	1700	1237	1335	2489	1775	1845	3384	2299	2350
350	2500	1480	1610	4115	2104	2270	5393	2712	2910
500	3600	1836	2650	4836	2651	3500	6900	3441	4340
750	6250	3482	3270	8583	5042	4895	13183	6564	6530
1000	8750	4244	5350	13275	6345	7675	19462	8388	9935
1500	16500	10023	N/A	22863	14735	N/A	35378	19304	N/A
2000	24300	12744	N/A	36688	19202	N/A	54737	25450	N/A
3000	28900	18176	N/A	44789	28096	N/A	98007	37797	N/A
5000	78500	29868	N/A	116406	48349	N/A	187579	66541	N/A





# Other Transformer Products

## Control Power Transformers

### Type T, Type K

#### Type T

- Rated for IEC, UL, CSA and NOM
- Tri-lingual markings (English, Spanish and French)
- Fingersafe® cover accessories allow OEMs to apply “CE” mark on their machinery
- Declaration of Conformity to EN60 742
- All the Features of the Type K

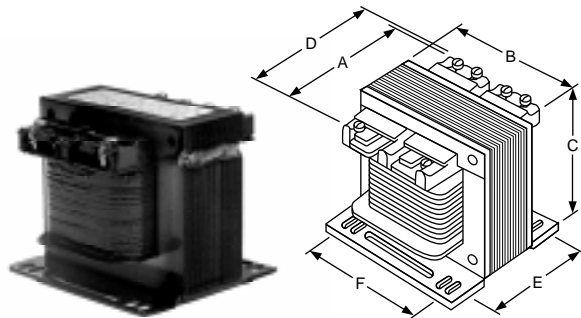

9070T150D1

Figure 1

#### Type T D1= 240/480V-120V, 230/460V-115V, 220/440V-110V, 50/60 Hz

Type & Voltage Code▲	UL VA Rating	IEC VA Rating	Dim./Accs. Code◆
T25D1	25	25	T1
T50D1	50	50	T1
T75D1	75	75	T2
T100D1	100	100	T3
T150D1	150	150	T4
T200D1	200	200	T5
T250D1	250	160	T6
T300D1	300	200	T7
T350D1	350	250	T8
T500D1	500	300	T9
T750D1	750	500	T10
T1000D1	1000	630	T11

#### Type T

Type & Voltage Code (D18, 20, 32)	UL VA Rating	IEC VA Rating	Dim./Accs. Code◆
T25	25	25	T2
T50	50	50	T2
T75	75	75	T4
T100	100	100	T4
T150	150	150	T5
T200	200	200	T7
T250	250	160	T8
T300	300	200	T8
T350	350	250	T9
T500	500	300	T10
T750	750	500	T11
T1000	1000	630	N/A

▲ The following voltage codes will have the same dimensions as their respective VA sizes from the D1 codes: D1, D2, D3, D4, D5, D12, D13, D14, D15, D23, D31, D33.  
◆ See table below for dimensions.

#### Type T

Type & Voltage Code	Dimensions – See Figure 1						Terminal Covers	Slot	Wt. (lbs)
	A	B	C	D★	E	F			
T1	3.09	3.00	2.58	3.84	2.00	2.50	FSC-1	.20 x .38	2.6
T2	3.34	3.38	2.89	4.09	2.38	2.81	FSC-1	.20 x .48	3.6
T3	3.34	3.38	2.89	4.09	2.38	2.81	FSC-1	.20 x .48	3.6
T4	3.59	3.75	3.20	4.34	2.88	3.13	FSC-1	.20 x .38	5.1
T5	3.59	3.75	3.20	4.34	2.88	3.13	FSC-1	.20 x .38	5.1
T6	5.25	3.75	3.25	6.05	2.88	3.13	FSC-2	.20 x .38	7.3
T7	4.70	4.50	3.80	5.50	2.56	3.75	FSC-2	.20 x .38	8.6
T8	5.09	4.50	3.80	5.89	3.00	3.75	FSC-2	.20 x .38	9.9
T9	5.46	4.50	3.80	6.26	3.56	3.75	FSC-2	.20 x .38	11.5
T10	5.66	5.25	4.43	6.46	3.43	4.38	FSC-2	.28 x .56	16.9
T11	6.04	5.25	4.43	6.84	4.31	4.38	FSC-2	.28 x .56	19.3

★ Width dimensions with fingersafe covers on.

#### Type K

- Vacuum Impregnated
- Flexible Mounting Plates
- Copper magnet wire

#### Type K, Standard Single Phase D1=240/480V-120V, 230/460V-115V, 220/440V-110V, 50/60 Hz

Type and Voltage Code	VA	Dimensions — See Figure 1						Weight
		A	B	C	E	F	Slot	
K50D1	50	3.09	3.00	2.58	2.00	2.50	.20 x .38	2.6
K75D1	75	3.34	3.38	2.89	2.38	2.81	.20 x .48	3.2
K100D1	100	3.34	3.38	2.89	2.38	2.81	.20 x .48	3.6
K150D1	150	3.59	3.75	3.20	2.88	3.13	.20 x .48	5.1
K200D1	200	4.81	4.50	3.75	2.50	3.75	.20 x .38	7.8
K250D1	250	5.19	4.50	3.75	2.88	3.75	.20 x .38	9.2
K300D1	300	4.88	4.50	3.75	2.56	3.75	.20 x .38	8.0
K350D1	350	5.31	4.50	3.75	3.00	3.75	.20 x .38	10.0
K500D1	500	5.88	4.50	3.75	3.56	3.75	.20 x .38	12.2
K750D1	750	5.56	5.25	4.38	3.44	4.38	.28 x .41	15.4
K1000D1	1000	6.50	5.25	4.38	4.31	4.38	.28 x .41	20.3
K1500D1	1500	6.62	7.06	6.56	4.13	5.81	.28 x .56	30.0
K2000D1	2000	6.94	7.06	6.56	4.44	5.81	.28 x .56	35.0
K3000D1	3000	7.91	9.00	9.50	4.63	7.63	.44 x .69	52.0
K5000D1	5000	9.63	9.00	9.50	6.56	7.63	.44 x .69	84.0

Types shown in bold type are normally stocked items.

★ The following voltage codes will have the same dimension as their respective VA sizes from the D1 codes: D1, D2, D3, D4, D5, D12, D13, D14, D15, D23, D31, D33.



## Other Transformer Products

### Control Power Transformers

#### Type TF and Type KF

#### Type TF and KF

Type TF KF transformers can help panel builders and machinery OEMs comply with the revised UL Standard 508 and NEC 450. The primary fuse clips accommodate Class CC time delay, rejection type fuses. The secondary fuse clips use a midget (1.5" x 13/32") fuse. Type TF and KF transformers help to free up space, reduce labor and additional costs associated with purchasing, stocking and installing separate fuse blocks. The Type TF transformers, with the use of the Fingersafe® cover accessories and fuse pullers, comply with "CE" requirements.

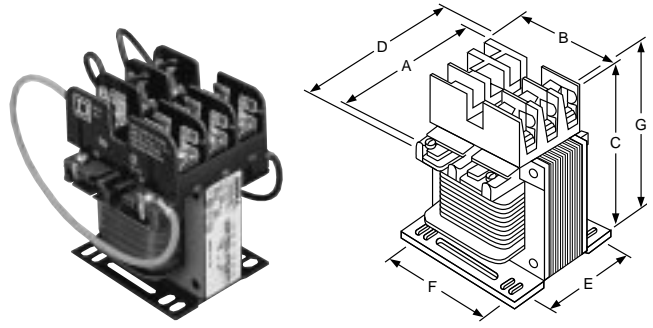

9070TF150D1

Figure 2

#### Type TF (with top mounted fuse block) D1=240/480V-120V, 50/60 Hz

Type & Voltage Code▲	UL VA Rating	IEC VA Rating	Dim./Accs. Code◆
TF25D1	25	25	TF1
TF50D1	50	50	TF1
TF75D1	75	75	T2F
TF100D1	100	100	TF3
TF150D1	150	150	TF4
TF200D1	200	200	TF5
TF250D1	250	160	TF6
TF300D1	300	200	TF7
TF350D1	350	250	TF8
TF500D1	500	300	TF9
TF750D1	750	500	TF10
TF1000D1	1000	630	TF11

#### Type TF (with top mounted fuse block)

Type & Voltage Code (D18, 20, 32)	UL VA Rating	IEC VA Rating	Dim./Accs. Code◆
TF25	25	25	TF2
TF50	50	50	TF2
TF75	75	75	TF4
TF100	100	100	TF4
TF150	150	150	TF5
TF200	200	200	TF7
TF250	250	160	TF8
TF300	300	200	TF8
TF350	350	250	TF9
TF500	500	300	TF10
TF750	750	500	TF11
TF1000	1000	630	N/A

▲ The following voltage codes will have the same dimensions as their respective VA sizes from the D1 codes: D1, D2, D3, D4, D5, D12, D13, D14, D15, D23, D31, D33.  
◆ See table below for dimensions.

#### Type TF

Type & Voltage Code	Dimensions — See Figure 2							Terminal Covers	Slot	Wt. (lbs)
	A	B	C	D★	E	F	G■			
T1	3.09	3.00	4.00	3.84	2.00	2.50	4.20	FSC-1	.20 x .38	2.9
T2	3.34	3.38	4.25	4.09	2.38	2.81	4.45	FSC-1	.20 x .48	3.9
T3	3.34	3.38	4.25	4.09	2.38	2.81	4.45	FSC-1	.20 x .48	3.9
T4	3.59	3.75	4.55	4.34	2.88	3.13	4.75	FSC-1	.20 x .38	5.4
T5	3.59	3.75	4.55	4.34	2.88	3.13	4.75	FSC-1	.20 x .38	5.4
T6	5.25	3.75	4.55	6.05	2.88	3.13	4.75	FSC-2	.20 x .38	7.6
T7	4.70	4.50	5.10	5.50	2.56	3.75	5.30	FSC-2	.20 x .38	8.9
T8	5.09	4.50	5.10	5.89	3.00	3.75	5.30	FSC-2	.20 x .38	10.2
T9	5.46	4.50	5.10	6.26	3.56	3.75	5.30	FSC-2	.20 x .38	11.8
T10	5.66	5.25	5.73	6.46	3.43	4.38	5.93	FSC-2	.28 x .56	17.2
T11	6.04	5.25	5.73	6.84	4.31	4.38	5.93	FSC-2	.28 x .56	19.6

★ Width dimensions with fingersafe covers on.  
■ Height dimensions with fingersafe covers on.

#### Type KF D1=240/480V-120V, 50/60 Hz

Type and Voltage Code	VA	Dimensions — See Figure 2						Weight
	60 Hz	A	B	C	E	F	Slot	
KF50D1	50	3.09	3.00	3.87	2.00	2.50	.20 x .38	2.9
KF75D1	75	3.34	3.38	4.19	2.38	2.81	.20 x .48	3.9
KF100D1	100	3.34	3.38	4.19	2.38	2.81	.20 x .48	3.9
KF150D1	150	3.59	3.75	4.50	2.88	3.13	.20 x .38	5.4
KF200D1	200	4.81	4.50	5.06	2.50	3.75	.20 x .38	8.1
KF250D1	250	5.19	4.50	5.06	2.88	3.75	.20 x .38	9.5
KF300D1	300	4.88	4.50	5.06	2.56	3.75	.20 x .38	8.3
KF350D1	350	5.31	4.50	5.06	3.00	3.75	.20 x .38	10.3
KF500D1	500	5.88	4.50	5.06	3.56	3.75	.20 x .38	12.5
KF750D1	750	5.56	5.25	5.69	3.44	4.38	.28 x .41	15.7
KF1000D1	1000	6.50	5.25	5.69	4.31	4.38	.28 x .41	20.6

★ The following voltage codes will have the same dimension as their respective VA sizes from the D1 codes: D1, D2, D3, D4, D5, D12, D13, D14, D15, D23, D31, D33.



# Other Transformer Products

## Control Power Transformers

### Type E D1=240/480V-120V

Type	VA		Dimensions — See Figure 3						Weight	Dim./Accessory Code★
	60 Hz	50 Hz	A	B	C	E	F	Slot		
EO17D1	25	25	3.31	3.00	2.50	1.75	2.50	.20 x .38	1.9	EF1
EO1D1	50	35	3.31	3.00	2.50	2.00	2.50	.20 x .38	2.2	EF2
EO18D1	75	75	3.78	3.38	2.81	2.19	2.81	.20 x .38	3.5	EF3
EO2D1	100	70	3.78	3.38	2.81	2.38	2.81	.20 x .38	3.8	EF4
EO3D1	150	120	4.44	3.75	3.13	2.88	3.13	.20 x .38	6.0	EF5
EO4D1	300	240	5.56	4.50	3.75	3.25	3.75	.20 x .38	10.5	EF6
EO16D1	350	280	6.19	4.50	3.75	3.81	3.75	.20 x .38	13.2	EF7
EO51D1	500	400	6.56	5.25	4.38	3.81	4.38	.28 x .41	17.2	EF8
EO61D1	750	500	7.94	5.25	4.38	5.13	4.38	.28 x .41	24.5	EF9
EO71D1	1000	900	7.94	6.00	5.00	4.75	5.00	.28 x .63	30.5	EF10
EO81D1	1500	1300	8.59	7.06	6.03	5.88	5.81	.44 x .69	45.0	EF11
EO91D1	2000	1800	9.22	7.06	6.03	6.50	5.81	.44 x .69	56.0	EF12
EO10D1	3000	3000	9.44	9.00	8.38	5.88	7.63	.44 x .69	72.0	EF13
EO11D1	5000	5000	12.06	9.00	8.38	8.50	7.63	.44 x .69	115.0	EF14

★ The following voltage codes will have the same dimension as their respective VA sizes from the D1 codes: D1, D2, D3, D4, D5, D12, D13, D14, D15, D23, D31, D33.

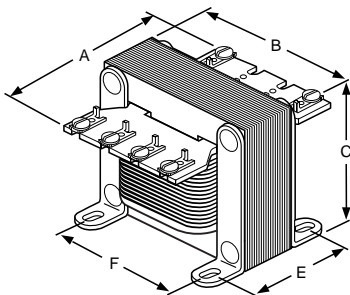
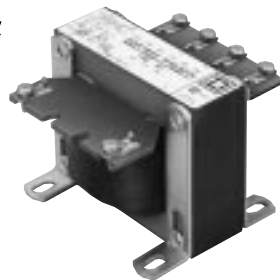

Figure 3



Type EO3D1

### Cross Reference★

EO1	K50
EO18	K75
EO2	K100
EO3	K150
EO19	K200
EO15	K250
EO4	K300
EO16	K350
EO51	K500
EO61	K750
EO71	K1000
EO81	K1500
EO91	K2000
EO10	K3000
EO11	K5000

★ Cross reference is for VA size only. Type E is not directly replaceable by Type K in all sizes. Please compare dimensions.

### Type T Field Installable Accessories

Part No.	Description	Notes
FP-1	Fuse puller Kit, used on all TF units	3 pullers/kit, 10 kit minimum, available in bulk packaging of 150 pullers by adding a B to the end of the catalog number.
FSC-1 FSC-2	Finger-protected cover kit to be used on 25VA to 200VA Finger-protected cover kit to be used on 250VA to 1000VA	2 covers/kit, 10 kit minimum, available in bulk packaging of 100 covers by adding a B to the end of the catalog number.
FSC-23	Finger-protected cover kit to be used with all VAs with voltage codes D19, D35, D40 or D41	2 covers/kit, 1 kit minimum.
SF25A★ SF25B★	Secondary fuse block kit to be used on 25VA to 200VA Secondary fuse block kit to be used on 250VA to 1000VA	Accommodates 1/4" x 1 1/2" size fuse.
SF41A★ SF41B★	Secondary fuse block kit to be used on 25VA to 200VA Secondary fuse block kit to be used on 250VA to 1000VA	Accommodates a midjet 1 1/2" x 1 3/32" size fuse.
FB-1A● FB-1B●	1-Pole non-rejection fuse block, and FSC-1 1-Pole non-rejection fuse block, and FSC-2	Accommodates a 1 1/2" x 1 3/32" size fuse.
FB-2A● FB-2B●	2-Pole non-rejection fuse block, and FSC-1 2-Pole non-rejection fuse block, and FSC-2	Accommodates a 1 1/2" x 1 3/32" size fuse.
FB-3A● FB-3B●	3-Pole, 2 rejection and 1 non-rejection fuse block, and FSC-1 3-Pole, 2 rejection and 1 non-rejection fuse block, and FSC-2	Accommodates a 1 1/2" x 1 3/32" size fuse.

\* Cannot be used when CE is required, can also be factory installed by adding to end of catalog number, i.e. 9070T50D1SF25.

● Can be used with the FP-1 and one additional cover to meet CE requirements.

### Other Field Installable Secondary Fusing

Part No.	Description
AP1	2" x 5/16" fuse size used on Type EO, 25 to 500VA; Type K, 50 to 500VA; and Type T 25 to 500VA
AP2	1 1/4" x 1/4" fuse size used on Type EO, 25 to 350VA; Type K, 50 to 500VA; and Type T 25 to 500VA
AP3	1 1/4" x 1/4" fuse size used on Type EO, 25 to 150VA and Type K, 50 to 150VA ♦
AP4	1 1/4" x 1/4" fuse size used on Type EO, 200 to 750VA and Type K, 200 to 1000VA

♦ Use AP4 kit for 9070K150D18, D19, D20 and D32.



**Voltage Codes for Wiring Diagrams**

Voltage Code	Primary-Secondary Voltage	Circuit Diagram
D1	220/440-110 230/460-115 240/480-120	2
D2	240/480-24	2
D3	208-120	1
D4	277-120	1
D5	550-110 575-115 600-120	1
D6	380-110	1
D8 ●	220-110 230-115 240-120	1
D9 ●	440-110 460-115 480-120	1
D12	440-220 460-230 480-240	1
D13	120-12/24	7
D14	208-24	1
D15	240/480-24/120	5
D16	600-24	1
D17	415-110	1
D18	208/277/380-95/115	32
D19 ★	208/240/277/380/480-24	20
D20	208/230/460-115	13
D22	480-277	1
D23	120/240-24	2
D24	110-110 115-115 120-120	1
D25	277-24	1
D26	208/240/416/480-120	...
D27	208/240/480-120	13
D31	220/440-110/220 230/460-115/230 240/480-120/240	5
D32	220/440/550-90/110 230/460/575-95/115 240/480/600-100/120	32
D33	380/400/415-115/230	21
D34	208/480/575-120	13
D35 ★	208/230/380/440/460-110/115	...
D36	600-12/24	7
D37	600-120/240	7
D38	240/480-12	2
D39	208/380/416-95/115	32
D40 ★	208/240/380/416/480-120	...
D41 ★	208/230/400/440/460-110/115	...

- Use Codes D8 and D9 on transformers with leads only. On other requests with these voltages please use the stocked Code D1.
- ★ Use Finger-protected cover kit FSC-23.

**Ordering Information**

**Example**      Class      Type

                         9070      T      F      50      D1

Type T or K  
Control Transformer

With top mounted  
fuse block

VA Size  
50VA    200VA    500VA  
75VA    250VA    750VA  
100VA   300VA   1000VA  
150VA   350VA

Voltage Codes  
D1 – 240/480-120V  
D2 – 240/480-24V  
D3 – 280-120V  
D4 – 277-120V  
D5 – 600-120V  
D23 – 120/240-24V

**Wiring Diagrams**

Circuit diagrams below represent transformer connection configuration for voltage codes listed below. Specific voltage arrangements are included on the label of each control transformer.

C.D.	Wiring Diagram	Price	Sec
1		Single V.	Single V.
2		Dual V.	Single V.
3		With 1 Tap	Single V.
4		Single V.	With 1 Tap
5		Dual V.	With 1 Tap
7		Single V.	Dual V.
8		Dual V.	Dual V.
13		With 2 Tap	Single V.
20		With 4 Tap	Single V.
21		With 2 Tap	Dual V.
32		With 2 Tap	With 1 Tap



# Other Transformer Products

## Open Core and Coil

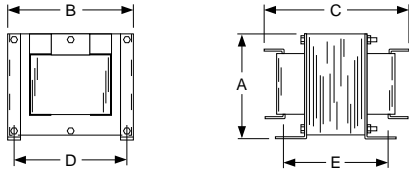

Figure 1

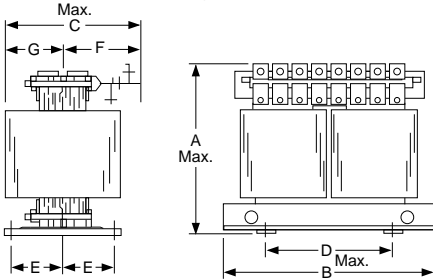

Figure 2

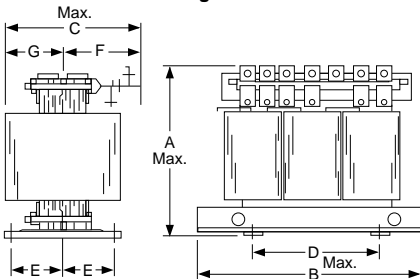
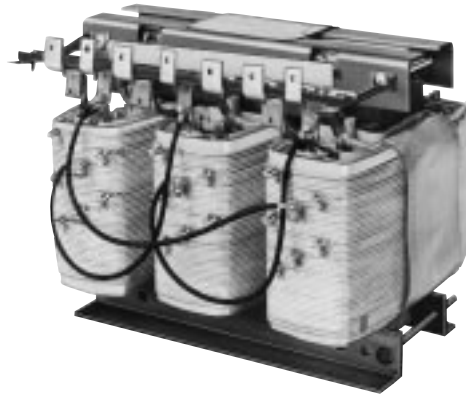

Figure 3



Dry Type Open Core and Coil

The compact space-saving design of Square D's open core and coil dry type transformers can be used in general applications. Additional features of open core and coil transformers include:

- Class 220°C insulation with 150° temperature rise.
- Aluminum windings
- Top terminated
- Available in single phase from 5-75 kVA and 3-phase from 9-112.5 kVA
- UL component recognized

### Single Phase

kVA	Catalog Number	Full Capacity Taps	Dimensions (IN)							Wt. (lbs)	Wiring ♦	Figure
			A	B	C	D	E	F	G			
<b>240x480 Volts Primary 120/240 Volts Secondary 60 Hz</b>												
5	5S1HFOC♦	None	8.0	9.0	11.0	8.0	7.75	—	—	66	1	1
7.5	7S1HOC	None	8.0	9.0	14.25	8.0	8.50	—	—	80	1	1
10	10S1HOC	None	8.0	9.0	14.25	8.0	8.50	—	—	100	1	1
15	15S1HOC	None	16.0	16.5	12.5	13.0	4.50	6.5	6.0	110	1	1
25	25S3HOC	6-2.5%2+4-▲	16.0	16.5	13.0	13.0	4.50	7.0	6.0	120	3	3
37.5	37S3HOC	6-2.5%2+4-▲	19.0	16.5	16.0	13.0	5.50	9.5	6.5	230	3	3
50	50S3HOC	6-2.5%2+4-▲	19.0	18.0	17.0	13.0	6.50	9.5	6.5	260	3	3
75	75S3HOC	6-2.5%2+4-▲	19.0	18.0	17.0	13.0	6.50	9.5	7.5	335	3	2

### Three Phase 60 Hz

kVA	Catalog Number	Dimensions (IN) – See Figure 3							Wt. (lbs)
		A	B	C	D	E	F	G	
9	9T( )HOC	13.0	18.0	12.5	16.0	4.0	6.5	6.0	120
15	15T( )HOC	13.0	18.0	12.5	16.0	4.0	6.5	6.0	120
30	30T( )HOC	16.0	18.0	12.5	16.0	4.5	6.5	6.0	170
45	45T( )HOC	16.0	18.0	16.0	16.0	4.5	8.5	7.5	260
75	75T( )HOC	19.5	21.0	16.0	16.0	6.5	8.5	7.5	365
112.5	112T( )HOC	19.5	21.0	19.5	16.0	8.0	9.0	10.5	565

### How to Order Three Phase

To complete the catalog number, select the voltage required from Table 1 and insert the voltage code in place of the parentheses ( ) in the catalog number.

Table 1

Voltage Code	Primary Voltage	Secondary Voltage	Full Capacity Taps★	Wiring ♦
12	240 Delta	208Y/120	4-2.5% 2+2-	11
3	480 Delta	208Y/120	6-2.5% 2+4-	10
8	600 Delta	208Y/120	4-2.5% FCBN	11

- ♦ 115°C temperature rise
- ♦ See Wiring Diagrams, Page 41.
- ▲ When 240V connection is used there will be 3-5% taps, 1 above and 2 below 240 volts.
- ★ FCBN full capacity taps below normal where noted.



## Other Transformer Products Motor Starting Autotransformers

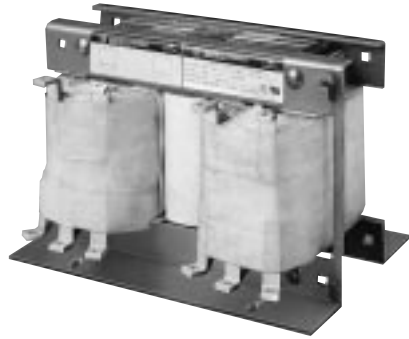

**Motor Starting Autotransformer**

### Application

Square D motor starting autotransformers offer a space-saving design for medium-duty motor starting service. Features of open core and coil transformers include:

- Class 220°C insulation
- Available in two-coil and three-coil designs
- 10-400 Horse Power
- 50%, 65%, 80%, 100% Taps

### How to Order

To complete the catalog number, select the voltage required from Table 1 and insert the voltage code in place of the parentheses ( ) in the catalog number.

**Table 1 Voltage Codes**

Voltage Code	Primary Voltage
200	208
201	240
202	480
203	600

### Two-Coil Motor Starting Autotransformer 60 Hz

Horse Power	Catalog Number	Dimensions (IN) - See Figure 1					Weight (lbs)	Fig.
		A	B	C	D	E		
10	MSA10T( )H2	7.5	10.5	8.0	9.0	6.0	45	1
20	MSA20T( )H2	7.5	10.5	8.0	9.0	6.0	45	1
30	MSA30T( )H2	7.5	10.5	10.0	9.0	7.5	65	1
50	MSA50T( )H2	7.5	10.5	10.0	9.0	7.5	65	1
75	MSA75T( )H2	8.5	12.25	10.25	9.0	7.5	95	1
100	MSA100T( )H2	8.5	12.25	10.25	9.0	7.5	95	1
125	MSA125T( )H2	11.0	14.5	10.5	9.0	7.5	125	1
150	MSA150T( )H2	11.0	14.5	10.5	9.0	7.5	125	1
200	MSA200T( )H2	11.0	14.5	10.5	9.0	7.5	145	1
250	MSA250T( )H2	14.25	17.0	9.0	9.0	9.0	160	1
300	MSA300T( )H2	14.25	17.0	12.25	9.0	9.0	180	1
400	MSA400T( )H2	16.0	19.25	13.0	9.0	9.0	225	1

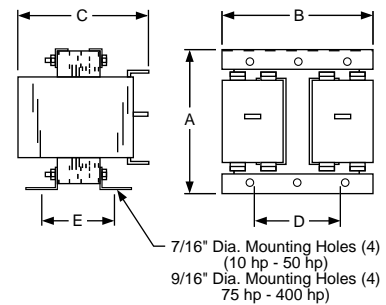

**Figure 1  
Two-Coil Autotransformer**

### Three-Coil Motor Starting Autotransformer 60 Hz

Horse Power	Catalog Number	Dimensions (IN) - See Figure 2					Weight (lbs)	Fig.
		A	B	C	D	E		
10	MSA10T( )H3	7.5	10.5	7.0	9.0	4.0	37	2
20	MSA20T( )H3	7.5	10.5	7.0	9.0	4.0	37	2
30	MSA30T( )H3	8.25	13.0	7.25	9.0	6.0	55	2
50	MSA50T( )H3	8.25	13.0	7.25	9.0	6.0	55	2
75	MSA75T( )H3	12.0	14.5	9.5	9.0	7.25	85	2
100	MSA100T( )H3	12.0	14.5	9.5	9.0	7.25	85	2
125	MSA125T( )H3	12.0	14.5	9.5	9.0	7.25	135	2
150	MSA150T( )H3	14.0	15.5	10.0	9.0	7.5	135	2
200	MSA200T( )H3	14.0	15.5	10.0	9.0	7.5	135	2
250	MSA250T( )H3	14.0	15.5	10.5	9.0	7.62	145	2
300	MSA300T( )H3	14.0	15.5	10.5	9.0	9.12	210	2
400	MSA400T( )H3	14.75	18.25	12.0	9.0	9.12	230	2

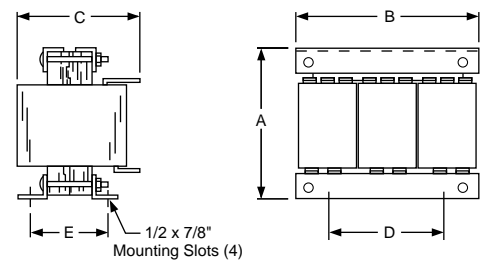

**Figure 2  
Three-Coil Autotransformer**



## Other Transformer Products

### Transformer Disconnects

#### Application

Transformer disconnects mount inside or outside a control system enclosure and provide power to auxiliary single-phase loads when the main three-phase disconnect is either “on” or “off”. The transformer disconnect is normally wired to the line side of the control panel's main disconnect. This convenient source of 120 volt power can be used for auxiliary or isolated loads, such as panel lighting, portable power tools, and programmable controller equipment.

#### Standard Features

The standard NEMA Type 1 enclosure is lockable for general purpose applications. The disconnect switch is rated at 45 amperes, 600 volts and has an external handle mechanically interlocked with the enclosure cover. The handle can lock in the “off” position. A standard fused and grounded transformer secondary is also included.

Primary fuse holders and secondary fuse holders for branch circuit protection are standard, complying with National Electrical Code requirements (two Class CC rejection-type fuse holders are supplied on the primary).

Square D offers two models of transformer disconnects:

- **Model MN** — Mini disconnect has a smaller enclosure with a pre-drilled standard outlet hole. (100 through 500VA)
- **Model SK** — Standard disconnect is available in small and large sizes (250 through 3000VA).

Standard features for both models include:

- **UL Listed:** File E137621. NEMA Type 1 & 12 enclosures.
- **CSA Certified:** File LR37055. NEMA 1 enclosures only.
- **Disconnect Switch** — Rated at 600V, 45A. Short-circuit withstand integrated rating of 100,000A when protected by Class CC fuses.
- **Enclosure** — NEMA Type 1 Rated.
- **Type KF or TF Transformer** — A Square D 230/460-115V Control Power Transformer provided with a top mounted fuse block that accepts two Class CC time delay primary fuses and one secondary fuse 1½ in. x 1¾ in.
- **Knockouts** — Conveniently located.
- **Ground Terminal.**
- **Flanges** — External mounting flanges with slotted holes provided for “hook and hang” mounting.
- **90° Access Cover Stop.**
- **Wide variety of units are stocked.**

#### Variations of Standard SK Model

The SK Model can have the following factory modifications (See Factory Modifications Table, Page 37):

- Add one or two outlet receptacles, either duplex, ground fault protected, or twist-lock.
- Substitute a 55°C rise high efficiency transformer or a shielded transformer.
- Add a red warning pilot light.
- Add an additional secondary fuse.
- Replace standard primary fuse blocks with 5 inch Class “R” fuse blocks.
- Substitute special voltage transformers.



Transformer Disconnects

#### How to Order

To Order Specify:	Catalog Number					
• Class No. 9070	Class	Type#	VA	Enclosure(s) Rating	Factory Modification	Voltage
• Type Number	9070	SK	1000	G1	P1	230/460-115
• VA Rating						
• Enclosure						
• Factory Modifications						
• Voltage						

#### Cross Reference

Old Square D Number	New Square D Number
SK5271M	MN100G0D1
SK5271N	MN250G0D1
SK5271Q, R	SK250G1D1
SK5271S, J	SK500G1D1
SK5271T, K	SK750G1D1
SK5271U	SK1000G1D1
SK5271V	SK1500G2D1
SK5271W	SK2000G2D1
SK5271X	SK3000G2D1

#### NEMA Type 1 Rated Transformer Disconnect

230/460 – 115V, 50/60Hz, Standard

Catalog Number	Transformer Continuous VA	Enclosure Size
MN100G0D1	100	0
MN250G0D1	250	0
MN500G0D1	500	0
SK250G1D1	250	1
SK500G1D1	500	1
SK750G1D1	750	1
SK1000G1D1	1000	1
SK1500G2D1	1500	2
SK2000G2D1	2000	2
SK3000G2D1	3000	2

#### NEMA Type 12 Rated Transformer Disconnect\*

230/460 – 115V, 50/60Hz

Catalog Number	VA
SK250A2D1	250
SK500A2D1	500
SK750A2D1	750
SK1000A2D1	1000
SK1500A2D1	1500
SK2000A2D1	2000
SK3000A2D1	3000

\* Rated NEMA Type 3R by adding form N3.



**Fusing – Now Standard in Type MN & SK Units**

Standard fuse holders accommodate:	
2 Primary	1½ in. x 1½ in. Class CC rejection-type
1 Secondary	1½ in. x 1³/₃₂

**Factory Modifications for NEMA Type 1 and NEMA Type 12 Rated Transformer Disconnect**

Model No.	Modification	Available on Sizes
G13▲	Duplex Receptacle, Door-Mounted	G0,G1,G2 & A2
G14▲★	Class A Ground Fault Protected Receptacle, Door-Mounted	G0,G1,G2 & A2
G15▲	Twist-Lock Receptacle, Door-Mounted	G1 & G2
G16▲	Two Duplex Receptacles, Door-Mounted	G2 & A2
E23■	Electrostatically-Shielded Transformer	G0,G1,G2 & A2
P1	"ON" Red Warning Pilot Light	G1,G2 & A2
◆	55°C Rise Transformer	G1,G2 & A2
F11■	Additional Fusible Secondary Circuit	G0,G1,G2 & A2
F30	Replace Standard 1½ in. x 1½ in. Class CC Primary Fuse Holders with 1½ in. x 5 in. Primary Fuse Holders	G2 & A2
N3	Convert NEMA Type 12 to NEMA Type 3R	A2
Special Voltages (see voltage chart)		G0, G1,G2,A2

**Note:** If either Model No. F30 or G16, or the combination of Model No. E23 and F11 are ordered on SK250G1 through SK1000G1, the Size 2 enclosure must be supplied. Therefore, the catalog numbers change to SK2501000G2 and a list price adder will apply.

- ▲ Not available with other receptacle options.
- Consult factory for inrush data.
- E23 and F11 not available together in Size 1 enclosure.
- ★ Must specify if CSA required.
- ◆ 55° rise transformer is standard in MN100G0, MN250G0, and SK250G1 units. Form "C" is not available on 3000VA units.
- ▼ Mini enclosure is limited to only one modification, restricted to E23, F11, G13, or G14.

**Voltage Codes**

Voltage Code	Primary Voltage	Secondary Voltage
D1	220/440	110
	230/460	115
	240/480	120
D3	208	120
D4	277	120
D5	550	110
	575	115
	600	120
D6	380	110
D17	415	110
D24	110	110
	115	115
	120	120

Please Contact Local Square D Field Office for other Voltages

**Dimensions**

Enclosure	A		B		C		D		E		F		G		H		I		J		K (DIA.)	
	IN	mm	IN	mm	IN	mm	IN	mm	IN	mm	IN	mm	IN	mm	IN	mm	IN	mm	IN	mm	IN	mm
G0	10.30	261	2.00	51	2.65	67	11.30	286	7.00	177	7.81	198	15.25	386	2.09	53	0.32	8	1.00	25	...	...
G1	10.80	274	1.70	43	6.00	152	11.80	300	9.40	239	8.96	228	16.81	427	2.09	53	0.32	8	1.00	25	...	...
G2	13.80	351	1.70	43	10.00	254	14.80	376	13.40	340	12.21	310	23.06	586	2.09	53	0.32	8	1.00	25	...	...
A2	13.50	342	2.86	72	6.00	152	14.50	367	16.50	417	13.49	341	25.56	647	2.44	62	4.25	108	15.75	398	.32	8

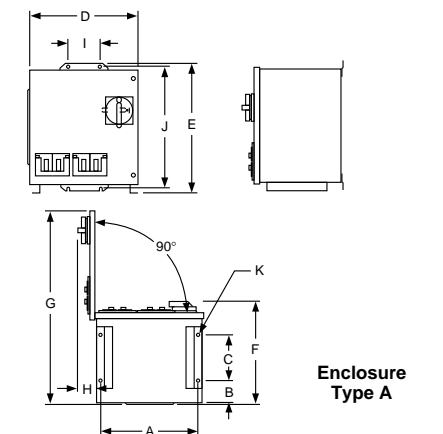
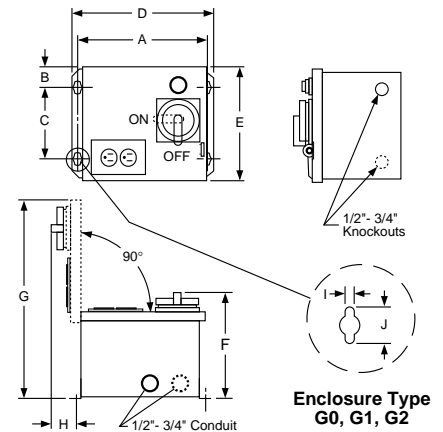
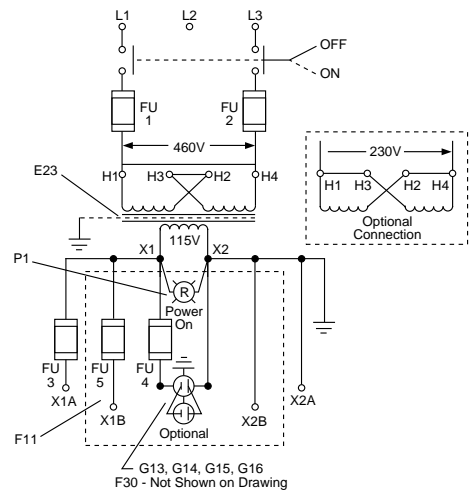



## Transformer Installation

### Installation Clearances

A dry type ventilated transformer depends on the free flow of air for cooling and proper operation. Ventilation openings must be at least 6 inches from any wall or obstruction. Local code restrictions may require different installation clearances.

### Enclosure Grounding

The core and coil assembly of a ventilated transformer rests on rubber isolation pads within the enclosure. This minimizes noise transmission and isolates the transformer from the enclosure. The core assembly is grounded to the enclosure at the factory. For proper installation, the enclosure must be solidly grounded to prevent electrical hazard.

### Neutral Grounding

The load side of a transformer is considered a separately derived source. If one of the conductors on the load side is a neutral, the National Electrical Code requires the conductor to be solidly grounded to an available building ground. When comparing phase-to-ground and phase-to-neutral voltage readings, significant differences in those readings may indicate improper neutral grounding. Grounding of transformer secondaries without neutrals is not necessary. In such cases, phase-to-ground voltage measurements are unpredictable and normally insignificant.

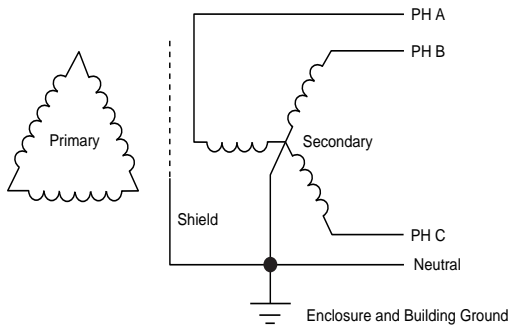

### Proper Use and Selection of Taps

Taps are usually supplied on the primary winding to allow matching of the supply voltage to the voltage rating of the transformer connection. Selection of a tap position above the nominal connection will lower the secondary output and vice-versa. Taps should not be used to raise a secondary output voltage that has fallen due to temporary loading situations. When the loads return to normal a high voltage condition can cause equipment damage.

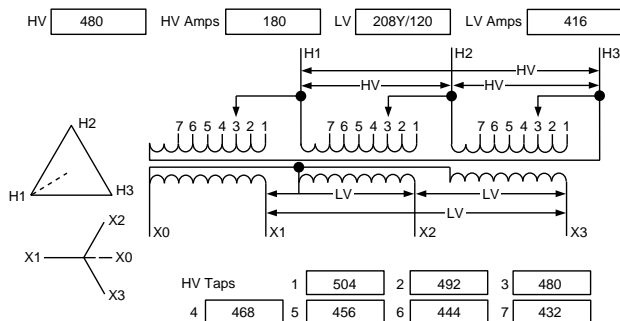

## Electrostatic Shield Grounding

For most applications the shield, secondary neutral, and enclosure grounding must be grounded to an available building ground. Some special installations require non-standard shield connections. Such circumstances must be completely specified by the electrical designer.

## Loads and Transformer Temperature

### Overloading of Transformers

In general, a dry type transformer *cannot* be overloaded without damaging the insulation system and reducing the transformer's life. Complete failure of the transformer is possible depending on the severity of an overload.

### Temperature Rise vs. Overload Capacity

Reduced temperature rise is the only valid way to provide continuous overload capabilities. Square D's WATCHDOG® transformers are designed with additional capacity beyond their nameplate rating. The 115°C rise units have 15% extra capacity, while the 80°C rise transformers have an extra 30% capacity.

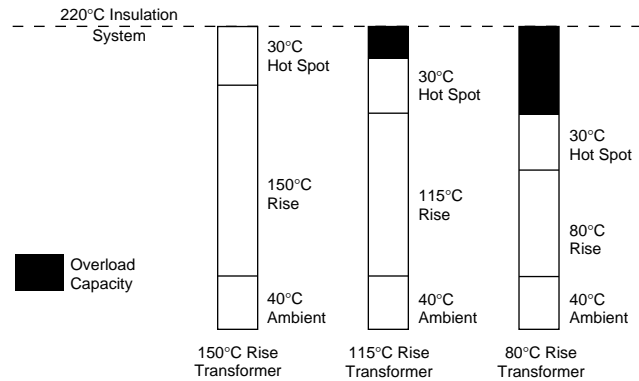

### Effects of Non-Linear Loads

Transformers generate heat which raises the external temperature of the enclosure. Standards define enclosure temperature as the sum of the ambient temperature and the temperature rise of the enclosure. Enclosure temperatures as high as 90°C are considered normal.

- **Drive Isolation Applications** – AC and DC drives cause distorted current to flow in the windings of transformers supplying power to the drives. The resulting additional heating and mechanical stress must be allowed for in the transformer design. Use of standard general purpose lighting transformers for this application is not recommended. Square D stocks a complete line of drive isolation transformers specifically designed for AC and DC drive application.
- **Other Electronic Load Applications** – Many types of loads cause distorted current waveforms. Some of these loads are common office automation equipment such as personal computers, copiers, FAX machines and printers. Others are SCR controlled process systems, lighting controls, UPS systems and discharge lighting. If the current



distortion is high enough, it can cause overheating of system neutrals and transformers. Square D offers application assistance and measurement and analysis services.

**Overcurrent Protection for Lighting Transformers**

The National Electrical Code, Article 450-3 requires both primary and secondary overcurrent protection, either in the form of circuit breakers or fuses. Square D offers application assistance in breaker and fuse sizing.

Transformer Performance Considerations

**Inrush and Excitation Current**

- **Definitions** – Inrush is a high, initial peak of current occurring during the first few cycles of transformers energization. Excitation current is the steady-state current that keeps the transformer energized after the inrush has dissipated.

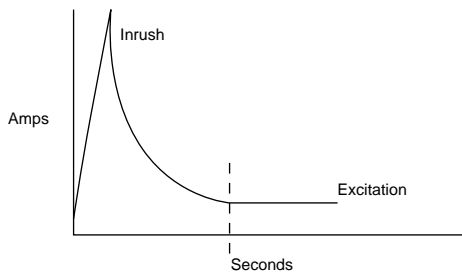

- **Inrush problems when backfeeding transformers** – The magnitude of the inrush is significantly increased when backfeeding a transformer (the amount of increase is dependent on the individual design). This high inrush can cause breakers to trip unnecessarily or fuses to blow. Increasing the rating of the primary overcurrent protection may be necessary.

*Note: When operating Delta-Wye transformers in reverse, the neutral connection must not be connected or grounded when the Wye side is used as a primary.*

**Impedance**

- **Definition** – Impedance, usually designated as %IZ, is a way of expressing the amount of current-limiting effect the transformer will represent if the load side of the transformer becomes short-circuited. Considered along with the X/R ratio, the information is used for systems analysis to determine proper interrupting ratings and coordination of protective devices.
- **Use of impedance to determine interrupting capacity** – Knowing the maximum current available on the load side of a transformer is necessary to properly choose current interrupting values for disconnects and overcurrent protective devices. Here is a simple method of estimating short circuit current:

$$\text{SECONDARY SHORT CIRCUIT CURRENT} = \frac{\text{TRANSFORMER SECONDARY FULL LOAD RATING}}{\text{TRANSFORMER IMPEDANCE}}$$

EXAMPLE: A TRANSFORMER WITH 208 AMPERES FULL LOAD CURRENT AND 5% IMPEDANCE

$$\text{SECONDARY SHORT CIRCUIT} = \frac{208}{.05} = 4160 \text{ AMPERES}$$

Other factors besides impedance affect short circuit current. Primary system capacity and motor current contribution from the load side will change the short circuit value obtained using the above simplified method. Make sure to take all factors into account to ensure that device interrupting ratings are properly coordinated. Contact your local Square D representative for information on system analysis service.

Transformer Performance Considerations

**Impedance**

- **When not to specify impedance** – Transformer impedance will vary depending on transformer size, voltage, winding material and many other factors. Although non-standard impedances are obtainable, they usually require additional cost. Only a specific reason should prompt specifying impedance, allowing manufacturers to supply their standard designs is more cost effective.

**Transformer Voltage Regulation**

- **Definition** – Transformer regulation is defined as the percentage difference between voltage at the secondary terminals under no-load condition and voltage under full load. This value depends on the load power factor and is usually reported at 1.0 PF and 0.8 PF.
- **Motor Starting Calculations** – The starting current of a motor can be as high as six or seven times the full-load running current. This initial high current can cause excessive voltage drop because of transformer regulation. Reduced voltage can cause the motor to fail to start and remain in a stalled condition, or it can cause the starter coil to release or “chatter”. A typical goal is to allow 10-12% maximum voltage drop at start. The voltage decrease during motor starting can be estimated as follows::

$$\text{VOLTAGE DROP (\%)} = \frac{\text{MOTOR LOCKED ROTOR CURRENT}}{\text{TRANSFORMER SECONDARY FULL LOAD RATING}} \times \text{IMPEDANCE (\%)}$$

EXAMPLE: TRANSFORMER HAS 833 AMPERES FULL LOAD CURRENT AND 6.3% IMPEDANCE AND IS SUPPLYING A MOTOR WITH 2500 AMPERES LOCKED ROTOR CURRENT

$$\text{VOLTAGE DROP (\%)} = \frac{2500}{833} \times 6.3 = 18.9\%$$

- **Other High Inrush Load Applications** – Certain control voltage requirements, such as magnetic starters and contactors, require better transformer regulation than that available with standard lighting transformers. Square D offers a full line of control power transformers designed for these high inrush applications.

Transformer Loss and Cost of Operation

**Energy Savings with Low Temperature Rise Transformers**

The phrase “lower losses” means reduced electrical costs to keep the units energized and running, reduced heat generation,



and lower air conditioning costs. Less heat also translates into longer transformer life. The WATCHDOG® transformers are low temperature rise units (80°C and 115°C). Their energy losses have been significantly reduced to achieve the lower temperature rise.

## Maximize Efficiency

Maximum transformer efficiencies can be obtained when the average loading is kept in the 60-80% range. Therefore, carefully review the required load profile before determining the kVA size of the transformer to be installed.

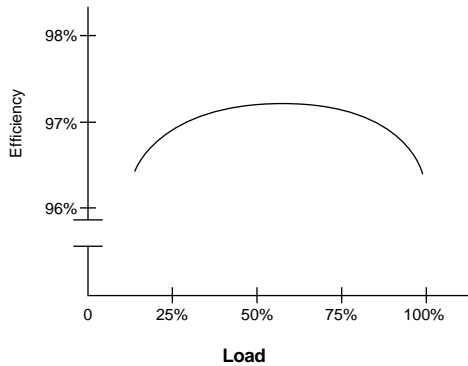

## Typical Questions

- Q. *What is the humming sound that occurs when a transformer is energized and how can it be minimized?*
- A. A phenomenon known as “magnetostriction” causes the hum. Core steel lamination lengthens and shortens as it reacts to the alternating magnetic field producing the sound. The humming noise is minimized by a quality manufacturing process and the use of sound dampening pads between the core and coil assembly and the enclosure mounting bars. Permissible sound levels are limited by standards and vary depending on transformer kVA size. If an application calls for sound levels below these standards, special transformer construction is required.
- Q. *Can a transformer manufactured for use at 60 Hz be operated at 50 Hz?*
- A. Lighting general purpose transformers with 60 Hz nameplate ratings should not be used for 50 Hz applications. However, transformers rated at 50 Hz or 50/60 Hz can be operated at 60 Hz.
- Q. *Can transformers with Delta (3-wire) primaries be used on Wye (4-wire) systems?*
- A. Yes, the neutral wire of the 4-wire service is simply not hooked up. Installing a Wye primary transformer on a Wye service is not necessary.

Q. *Why is there a 5% limit for single phase loading on Delta-Delta connected transformers with 240/120 center tapped secondaries?*

- A. Delta-Delta connected transformers are intended to supply balanced three-phase loads, such as motors. Unbalanced loading will cause a circulating current to flow in the windings. This additional current is like a “hidden” load within transformer windings and can severely de-rate or even overload the transformer. Adding a center tap on the secondary for a combination of a 240V three-phase and 120V single-phase loads will create an unbalance. The amount of unbalance is limited to 5% to prevent excessive circulating currents.

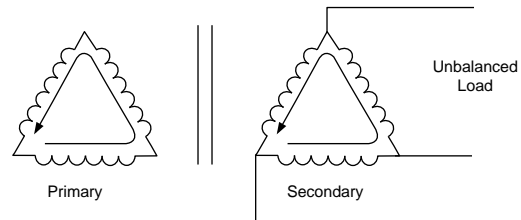

Q. *What is the difference between “isolating” and “insulating” transformers?*

- A. Insulating and isolating are both terms used to describe transformers with electrically separate primary and secondary windings. The windings are insulated from one another making the current within each winding closed off from the other. All transformers with electrically separate primary and secondary windings are both insulating and isolating. Isolation transformers may or may not have electrostatic shields.

Q. *Can transformers be used to convert single phase to three phase?*

- A. No, transformers cannot convert single-phase power to three-phase power. That conversion can only be done by motor generators, rotary phase converters, or electronic converters. Single-phase transformers can be connected to three-phase systems by simply connecting two-phase lines, or a single-phase and neutral to the primary of the transformer.

Q. *What are buck and boost transformers?*

- A. Buck and boost transformers are small isolating transformers that, connected as autotransformers, allow small corrections in voltage.

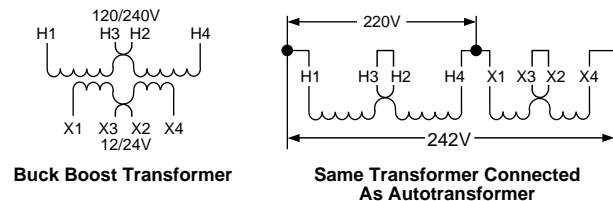

# Dry Type Transformers Wiring Diagrams 600 Volts and Below

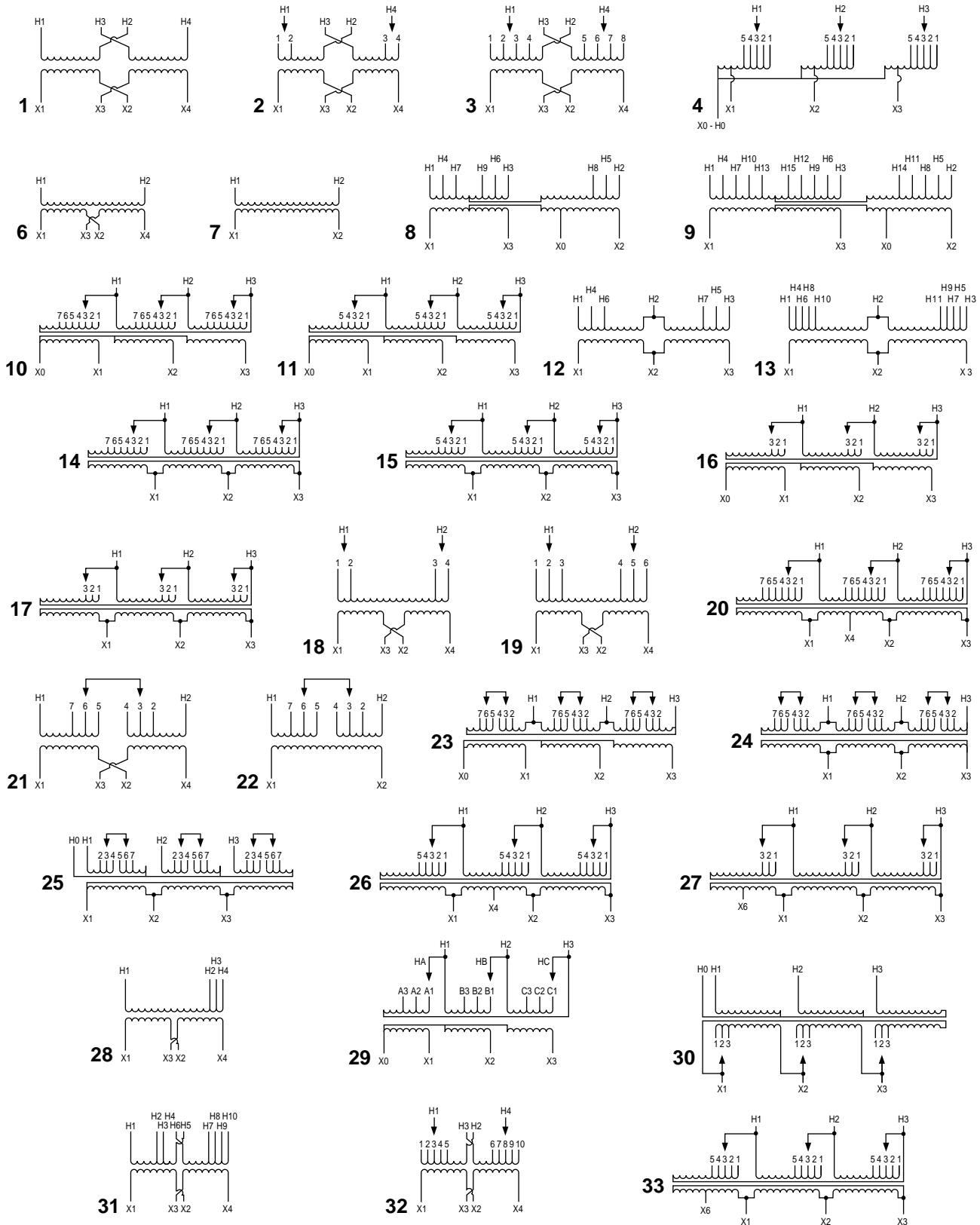

## **Transformers— large and small, look to Square D.**

Square D Company is a leading manufacturer and supplier of transformers, from small control transformers to large power transformers. The full line of Square D transformers is available from an extensive network of Square D sales offices and distributors located throughout North America.

Square D company is part of Group Schneider, a global manufacturer of transformers, electrical distribution, automation and industrial equipment.

Square D has been serving industrial, construction and utility markets, as well as individual consumers and government agencies for over 85 years. We offer unsurpassed quality, innovative design and a committed staff of trained sales representatives and service technicians willing to stand behind every product we sell.

For more information on how we can fulfill your electrical needs, call your Square D sales representative or authorized Square D distributor.



## Corner-Grounded Delta (Grounded B Phase) Systems Class 2700

Retain for future use.

### INTRODUCTION

Corner-grounded delta systems are not recommended for new installations. However, some utilities still provide this system, and many old installations still exist. Schneider Electric has tested equipment for use on corner-grounded delta systems to provide Underwriters Laboratories Inc.® (UL®) Listed products for this application.

This document outlines the background of the corner-grounded delta systems and lists the equipment rated for use on these systems.

### Background

In the past, delta-delta connected transformers were extensively used in electrical distribution systems. With this type of system, it was practical to continue distributing three-phase power while performing maintenance on one unit of the three-phase transformer bank. Now, with the advent of more reliable modern transformers and the popularity of three-phase units, the delta-delta connected transformer no longer has the advantage it once had.

One of the disadvantages of the delta-delta system is the absence of an intentional connection to ground on the transformer secondary. To obtain a grounded system, one of the corners of the delta secondary is grounded.

With decreased usage of the delta-delta connected transformer, and increased usage of delta-wye connected transformers, the corner-grounded delta is rarely applied in modern systems.

### Definitions

#### Corner-Grounded Delta System

A system in which the transformer secondary is delta-connected with one corner of the delta solidly grounded. Corner-grounded delta systems are also referred to as grounded B phase systems, grounded phase services, and end-grounded delta systems.

#### Ungrounded System

A system without an intentional connection to ground, except through potential indicating or measuring devices.

#### Grounded System

A system that has at least one conductor or point intentionally connected to ground, either solidly or through an impedance.

#### Solidly Grounded

An intentional connection made directly to ground without inserting any resistor or impedance.

Figure 1: System Diagram, 3 $\phi$ 3W Ground B $\phi$  Delta

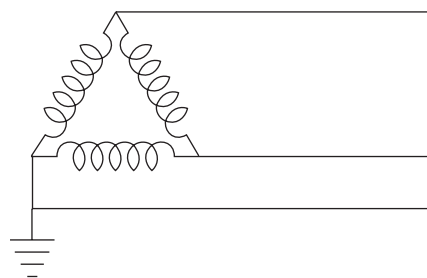

## STANDARDS

This section contains a list of standards that are applicable to corner-grounded delta systems. These standards address three basic points:

1. Any two-pole circuit breaker intended for use on corner-grounded delta systems shall be tested and rated for such use.
2. No overcurrent device is permitted to be used to disconnect the grounded conductor, unless this device simultaneously disconnects all conductors of the circuit, including the ground.
3. If the system is a corner-grounded delta system and fuses will be used for motor overload protection, a fuse must be installed in the grounded conductor, but only at the motor controller.

### NEMA Standards Publication No. PB 1

PB 1–7.7 Corner-Grounded (Grounded B Phase)  
Three-Phase Delta Applications

Two-pole circuit breakers intended to be installed on corner-grounded (grounded B phase) delta systems to supply three-phase loads shall be marked “1 phase - 3 phase.”

### NEMA Standards Publication No. PB 2

PB 2–7.9 Corner-Grounded (Grounded B Phase)  
Three-Phase Delta Applications

Two-pole circuit breakers intended to be installed on corner-grounded (grounded B phase) delta systems to supply three-phase loads shall be marked “1 phase–3 phase.”

### National Electrical Code® (NEC®)

240.85 Applications

A circuit breaker with a straight voltage rating, such as 240V or 480V, shall be permitted to be applied in a circuit in which the nominal voltage between any two conductors does not exceed the circuit breaker’s voltage rating.

**A two-pole circuit breaker shall not be used for protecting a 3-phase, corner-grounded delta circuit unless the circuit breaker is marked 1 $\phi$ -3 $\phi$  to indicate such suitability.**

A circuit breaker with a slash rating, such as 120/240V or 480Y/277V, shall be permitted to be applied in a solidly grounded circuit where the nominal voltage of any conductor to ground does not exceed the lower of the two values of the circuit breaker’s voltage rating and the nominal voltage between any two conductors does not exceed the higher value of the circuit breaker’s voltage rating.

**FPN:** Proper application of molded case circuit breakers on 3-phase systems, other than solidly grounded wye, particularly on corner grounded delta systems, considers the circuit breakers’ individual pole-interrupting capability.

Article 230.90 (B) Not in Grounded Conductor

No overcurrent device shall be inserted in a grounded service conductor except a circuit breaker which simultaneously opens all conductors of the circuit.

Article 240.22 Grounded Conductor

No overcurrent device shall be connected in series with any conductor that is intentionally grounded, unless one of the following two conditions are met:

- (1) The overcurrent device opens all conductors of the circuit, including the grounded conductor, and is designed so that no pole can operate independently.
- (2) Where required by Sections 430.36 or 430.37 for motor overload protection.

Article 404.2 Switch Connections

(A) Three-Way and Four-Way Switches. Three-way and four-way switches shall be wired so that all switching is done only in the ungrounded circuit conductor. Where in metal raceways or metal-armored cables, wiring between switches and outlets shall be in accordance with 300.20(A).  
*Exception: Switch loops shall not require a grounded conductor.*

(B) Grounded Conductors. Switches or circuit breakers shall not disconnect the grounded conductor of a circuit.  
*Exception: A switch or circuit breaker shall be permitted to disconnect a grounded circuit conductor where all circuit conductors are disconnected simultaneously, or where the device is arranged so that the grounded conductor cannot be disconnected until all the ungrounded conductors of the circuit have been disconnected.*

Article 430.36 Fuses—In Which Conductor

Where fuses are used for motor overload protection, a fuse shall be inserted in each ungrounded conductor and also in the grounded conductor if the supply system is three-wire, three-phase ac with one conductor grounded.

Schneider Electric adds the following clarification note to Article 430.36:

*NOTE: It is prohibited to fuse the grounded conductor on service or distribution disconnects.*

Article 430.85 In Grounded Conductors

One pole of the controller shall be permitted to be placed in a permanently grounded conductor, provided the controller is designed so that the pole in the grounded conductor cannot be opened without simultaneously opening all conductors of the circuit.

**UL Standard 67**

Paragraph 13.2.4

A two-pole circuit breaker, used in a panelboard marked for use on a corner-grounded delta system, shall be marked “1 $\phi$ -3 $\phi$ .”

Paragraph 13.5.2

An overcurrent device shall not be connected in the permanently grounded wire of any circuit unless opening of the overcurrent device simultaneously opens all the conductors in that circuit.

**UL Standard 891**

Paragraph 8.6.11.3

A two-pole circuit breaker intended for use on a 3-phase load shall be marked “1 $\phi$  – 3 $\phi$ ” when installed in a switchboard for use on a corner grounded delta system.

Paragraph 8.6.6.3

No overcurrent device shall be placed in any permanently grounded conductor unless it simultaneously opens all conductors of the circuit.

**UL Standard 489**

Paragraph 7.1.11.3.1.4

Two-pole circuit breakers are to be tested on a single-phase circuit with the load terminals short circuited. An additional two-pole sample shall be tested on a three-phase circuit if the circuit breaker is marked “1 $\phi$ -3 $\phi$ ”

**VOLTAGES**

**Table 1: Possible Low Voltage Corner-Grounded Delta Systems**

System Voltage	Phase-to-Phase Voltage	Description
120 V	120 V	The ungrounded phases, generally A and C phases, have the same phase-to-ground voltage, while B phase is solidly grounded.
240 V	240 V	
480 V	480 V	
600 V	600 V	



## THEORY

A corner-grounded delta system has the following characteristics:

- Grounding one phase stabilizes the voltage of the other two phases to ground.
- High fault currents may flow on the first ground fault, requiring the immediate clearance of this first fault.
- The voltage to ground in this system will be the system voltage, usually 240 or 480 volts.

Corner-grounded delta systems are not recommended for new installations because more suitable and reliable systems are available today. Even though this system is not recommended, it is encountered today for several reasons:

- As mentioned in the "Background" section on page 1, nearly all low voltage systems in the past were supplied from transformers with delta-connected secondaries. Grounding one of the phases provided a means of obtaining a grounded system. In this way, a grounded system could be obtained at a minimum of expense where existing delta transformer connections did not provide access to the system neutral.
- The recommended practice for most systems involves grounding one conductor of the supply.
- Possibly, customers wanted to avoid installing equipment ground fault protection as required by the NEC on solidly grounded wye electrical services.
- This system could result in the use of less expensive equipment, since two-pole switches and a neutral could be used for three-pole applications.

Corner-grounded delta systems have several advantages and disadvantages, as listed below.

## Advantages

Corner-grounded delta systems:

- Stabilize voltages of the ungrounded phases to ground.
- Reduce the generation of transient overvoltages.
- Provide a method for protecting electrical distribution systems when used in combination with equipment grounding.

## Disadvantages

Due to its disadvantages, the corner-grounded delta system has little reason for modern day use:

- The system is unable to supply dual-voltage service for lighting and power loads.
- It requires a positive identification of the grounded phase throughout the system.
- A higher line-to-ground voltage exists on two phases than in a neutral-grounded system.
- Most manufacturers' electrical distribution equipment is not rated for use on this system.
- Fault switching (opening) is much more severe for the clearing device, and ratings may be greatly reduced.

## Testing

Why isn't more equipment rated for corner-grounded delta systems?

Testing is required to get equipment rated for this system. Since the system is no longer frequently specified, most manufacturers do not test for its use.

**APPLICATION**

Schneider Electric has tested and obtained a UL listing for equipment to be used on grounded B phase systems. The “Devices” section on page 5 lists devices on unassembled and factory assembled distribution equipment that is suitable for such use. It is recommended to provide some type of equipment ground fault protection when the equipment is used on grounded B phase systems, due to the potential high fault currents on the first ground fault.

When ordering factory assembled equipment for use on grounded B phase systems, the order should be clearly identified as such on the order entry paperwork, because of the special requirements. Merchandised equipment must be properly selected and ordered from the Digest.

It is also recommended for engineers to specify that equipment is UL-labeled as suitable for use on grounded B phase systems, when applicable. This will ensure that our competitors quote and supply equipment rated for use on corner-grounded systems.

**DEVICES**

*NOTE: All equipment listed in this document is rated for use on systems with a grounded B phase.*

**BP Fusible Switches**

BP switches can be used on corner-grounded delta systems in manually or electrically operated, upright or inverted mount, and two- or three-pole<sup>2</sup> versions. The short-circuit current rating of BP switches on this system is 200,000 ampere interrupting rating (AIR) with Class L fuses installed.

**Table 2: BP Switches**

BP Switch Ampere Rating	Grounded B Phase System Rated	Maximum Grounded B Phase Voltage <sup>1</sup>
800	Yes	480 Vac
1200		
1600		
2000		
2500		

<sup>1</sup> For 240 V grounded B phase systems, use only 480 V BP switches listed in the table above.  
<sup>2</sup> Three-pole switches have a copper link inserted in the center phase to restrict insertion of a fuse into the grounded conductor.

**QMB and QMJ Switches**

Table 3 lists QMB and QMJ switches that are UL Listed in File E34358, Vol. 2, Section 1 for grounded B phase systems. Two- and three-pole switches listed in Table 3 are rated for grounded B phase. However, only two-pole switches are marked to indicate a grounded B phase rating. The short-circuit current rating for 30–200 A Series E1 switches is 200,000 AIR. The short-circuit current rating for Series E1 400–800 A switches is 50,000 AIR.

**Table 3: QMB and QMJ Switches**

QMB/QMJ Switch Series	QMB/QMJ Switch Ampere Rating	Grounded B Phase Rated					
		Main Switch	Branch Switch	240 Vac Unit	480 Vac Unit	Two-pole	Three-pole <sup>11</sup>
E1	30	N/A	Yes	Yes	Yes	Yes	Yes
	60						
	100						
	200						
	400						
	600						
800	Yes	N/A					

<sup>11</sup> Three-pole switches have a copper link inserted in the center phase to restrict insertion of a fuse into the grounded conductor. The rating is not shown on the wiring diagram of three-pole switches.

**Safety Switches**

Table 4 lists two-pole safety switches that are UL Listed for use on 240 and 480 Vac grounded B phase systems. Refer to the Digest, CAD drawings, or device wiring diagram(s) for complete information.

**Table 4: Safety Switches**

Safety Switches	Ampere Rating	System Voltage (VAC)	Type Construction	NEMA Types	Short Circuit Rating
General Duty	30	120	Neutral installed, e.g., D223N	1, 3R	10,000 A
	60	240			10,000 A when used in conjunction with Class H or K fuses. 100,000 A when used in conjunction with Class R, J, or T fuses.
	100				
	200				
Heavy Duty	30	240 or 480	Two-pole or three-pole, neutral installed, e.g., H223N	1, 3R, 4, 4X, 5, 12, 12K	10,000 A when used in conjunction with Class H or K fuses. 200,000 A when used in conjunction with Class R, J, or T fuses.
	60				
	100				
	200				
	400				
	600				

**Molded Case Circuit Breakers**

Table 5 lists molded case circuit breakers that are UL Listed for 240 Vac grounded B phase systems. Table 6 on page 7 lists UL Listed ratings available for use on 480 Vac grounded B phase systems.

**Table 5: 240 Vac UL Listed Grounded B Phase Interrupting Ratings**

Catalog Number Prefix	No. Poles <sup>1</sup>	Ampere Rating	UL Listed 240 Vac Grounded B Phase RMS Sym. Amperes	
Q0-H, Q0B-H	2	15–100	5,000	
QB, QD, QG, QJ	2 <sup>2</sup>	100–225	10,000	
EDB, EGB, EJB		15–125	18,000, 35,000, 65,000	
HD, HG, HJ, HL	2 <sup>3</sup>	15–150	25,000, 35,000, 65,000, 100,000	
JD, JG, JJ, JL		150–250		
FH-FHL <sup>4</sup>		15–100	42,000	
KH-KHL		70–250	42,000	
LH, LHL <sup>4</sup>		125–400	30,000	
MG, MJ Electronic		300–800	600–1200	65,000
PG, PJ, PK, PL Electronic				
RG Electronic				
RJ Electronic		1200–2500	100,000	
RL Electronic		1200–2500	125,000	
MG, MJ Electronic	3	300–800	65,000	
PG, PK Electronic		600–1200		
PG, PK Micrologic®		250–1200		
PJ, PL Electronic		600–1200	100,000	
PJ, PL Micrologic		250–1200		
RG, RK Electronic		1200–2500	65,000	
RG, RK Micrologic		600–2500		
RJ Electronic		1200–2500		
RJ Micrologic		600–2500	100,000	
RL Electronic		1200–2500	125,000	
RL Micrologic		600–2500		

<sup>1</sup> The grounded phase should be connected to the center pole only.

<sup>2</sup> Standard labeling includes grounded B phase.

<sup>3</sup> Built using three-pole module.

<sup>4</sup> Add suffix 5861 to the catalog number for grounded B phase labeling.

NOTE: Electronic = ET1.01 electronic trip system. Micrologic = 3.0, 5.0, 3.0A, 5.0A, 6.0A, 5.0P, 6.0P, 5.0H, and 6.0H Micrologic trip system.

**Table 6: 480 Vac UL Listed Grounded B Phase Interrupting Ratings**

Catalog Number Prefix	No. Poles <sup>1</sup>	Ampere Rating	UL Listed 480 Vac Grounded B Phase RMS Sym. Amperes
HD, HG, HJ, HL	3	15–150	18,000, 35,000, 65,000, 100,000
JD, JG, JJ, JL		150–250	
FH-FHL		15–100	25,000 <sup>2</sup>
KH-KHL		70–250	35,000 <sup>2</sup>
LH-LHL		125–400	
MH		300-1000	65,000 <sup>2</sup>
PH		2000A	100,000
MG, MJ Electronic, PG Micrologic		300-800	35,000,
PG Electronic		600–1200	
PG Micrologic		250–1200	
PK Electronic		600–1200	65,000
PK Micrologic		250–1200	
PJ Electronic/ PJ Micrologic		600–1200	65,000
		250–1200	
PL Electronic		600–1200	100,000
PL Micrologic		250–1200	
RG Electronic		1200–2500	35,000
RG Micrologic		600–2500	
RJ, RK Electronic		1200–2500	65,000
RJ, RK Micrologic		600–2500	
RL Electronic		1200–2500	100,000
RL Micrologic		600–2500	
NT		800–1200	100,000
NW		800–6000	150,000

<sup>1</sup> The grounded phase should be connected through the center pole only.

<sup>2</sup> UL pending

*NOTE: Electronic = ET1.01 electronic trip system. Micrologic = 3.0, 5.0, 3.0A, 5.0A, 6.0A, 5.0P, 6.0P, 5.0H, and 6.0H Micrologic trip system.*

## UNASSEMBLED AND ASSEMBLED EQUIPMENT

### Panelboards

#### QMB Panelboards

QMB panelboards are UL Listed for use on grounded B phase systems 240 or 480 Vac with appropriately rated switches installed.

#### I-Line<sup>®</sup> Circuit Breaker Panelboards, 240 Vac

I-Line panelboards are UL Listed to indicate a 3 $\phi$ 3W, 240 Vac grounded B phase rating with appropriately rated circuit breakers installed (see Table 5 on page 6 for 240 Vac circuit breakers).

#### I-Line Circuit Breaker Panelboards, 480 Vac

I-Line panelboards are UL Listed for use on 480 Vac grounded B phase systems with the appropriately rated circuit breakers installed when using the B phase as grounded.

#### NQOD and NF Circuit Breaker Panelboards

NQOD and NF panelboards are UL Listed and can be used on 3 $\phi$ 3W, 240 Vac grounded B phase systems with rated main circuit breakers installed (see Table 7).

**Table 7: NQOD and NF Circuit Breaker Panelboards**

Main Circuit Breaker Type	240 Vac Grounded B Phase Rated	
	NQOD	NF
QB, QD, QG, QJ	Yes	No
EDB, EGB, EJB	No	Yes
HD, HG, HJ, HL	Yes	Yes
JD, JG, JJ, JL		No
FH		No
KH		Yes
LH		
Main lugs only		

Branches for NF include EDB, EGB, and EJB. Branches for NQOD include QO-H and QOB-H.

**Switchboards**

QED custom switchboards are UL Listed for use on grounded B phase systems when properly rated devices are installed (see the “Devices” section beginning on page 5 for details about these devices). QED switchboards can be rated up to 480 Vac as shown in Table 8.

**Table 8: Switchboard Voltages**

Type of Switchboard	Grounded B Phase System Rating
Circuit breaker switchboards	240 Vac, 480 Vac
Fusible switchboards	240 Vac, 480 Vac

**REFERENCES**

- IEEE Standard 142, 1991: “IEEE Recommended Practice for Grounding of Industrial and Commercial Power Systems.”
- IEEE No. 241, 1990: “Electrical Systems for Commercial Buildings.”
- National Electrical Code, 2002.
- NEMA Standards: Publication No. PB1, 2000.
- NEMA Standards: Publication No. PB2, 2001.
- Underwriters Laboratories Standard 67, 2003.
- Underwriters Laboratories Standard 891, 2003.
- Underwriters Laboratories Standard 489, March 2003.

Schneider Electric USA  
1010 Airpark Center Drive  
Nashville, TN 37217 USA  
1-888-SquareD (1-888-778-2733)  
www.us.SquareD.com

Electrical equipment should be installed, operated, serviced, and maintained only by qualified personnel. No responsibility is assumed by Schneider Electric for any consequences arising out of the use of this material.

© 2002–2006 Schneider Electric All Rights Reserved



## Transformer Questions & Answers

### 1. What is a transformer and how does it work?

A transformer is an electrical apparatus designed to convert alternating current from one voltage to another. It can be designed to “step up” or “step down” voltages and works on the magnetic induction principle. A transformer has no moving parts and is a completely static solid state device, which insures, under normal operating conditions, a long and trouble-free life. It consists, in its simplest form, of two or more coils of insulated wire wound on a laminated steel core. When voltage is introduced to one coil, called the primary, it magnetizes the iron core. A voltage is then induced in the other coil, called the secondary or output coil. The change of voltage (or voltage ratio) between the primary and secondary depends on the turns ratio of the two coils.

### 2. What are taps and when are they used?

Taps are provided on some transformers on the high voltage winding to correct for high or low voltage conditions, and still deliver full rated output voltages at the secondary terminals. Standard tap arrangements are at two-and-one-half and five percent of the rated primary voltage for both high and low voltage conditions. For example, if the transformer has a 480 volt primary and the available line voltage is running at 504 volts, the primary should be connected to the 5% tap above normal in order that the secondary voltage be maintained at the proper rating. The standard ASA and NEMA designation for taps are “ANFC” (above normal full capacity) and “BNFC” (below normal full capacity).

### 3. What is the difference between “Insulating,” “Isolating,” and “Shielded Winding” transformers?

Insulating and isolating transformers are identical. These terms are used to describe the isolation of the primary and secondary windings, or insulation between the two. A shielded transformer is designed with a metallic shield between the primary and secondary windings to attenuate transient noise. This is especially important in critical applications such as computers, process controllers and many other microprocessor controlled devices. All two, three and four winding transformers are of the insulating or isolating types. Only autotransformers, whose primary and secondary are connected to each other electrically, are not of the insulating or isolating variety.

### 4. Can transformers be operated at voltages other than nameplate voltages?

In some cases, transformers can be operated at voltages below the nameplate rated voltage. In **NO** case should a transformer be operated at a voltage in excess of its nameplate rating, unless taps are provided for this purpose. When operating below the rated voltage, the KVA capacity is reduced correspondingly. For example, if a 480 volt primary transformer with a 240 volt secondary is operated at 240 volts, the secondary voltage is reduced to 120 volts. If the transformer was originally rated 10 KVA, the reduced rating would be 5 KVA, or in direct proportion to the applied voltage.

### 5. Can 60 Hz transformers be operated at 50 Hz?

ACME transformers rated below 1 KVA can be used on 50 Hz service. Transformers 1 KVA and larger, rated at 60 Hz, should not be used on 50 Hz service, due to the higher losses and resultant heat rise. Special designs are required for this service. However, any 50 Hz transformer will operate on a 60 Hz service.

**6. Can transformers be used in parallel?** Single phase transformers can be used in parallel only when their impedances and voltages are equal. If unequal voltages are used, a circulating current exists in the closed network between the two transformers, which will cause excess heating and result in a shorter life of the transformer. In addition, impedance values of each transformer must be within 7.5% of each other. For example: Transformer A has an impedance of 4%, transformer B which is to be parallel to A must have an impedance between the limits of 3.7% and 4.3%. When paralleling three phase transformers, the same precautions must be observed as listed above, plus the angular displacement and phasing between the two transformers must be identical.

### 7. Can Acme Transformers be reverse connected?

ACME dry-type distribution transformers can be reverse connected without a loss of KVA rating, but there are certain limitations. Transformers rated 1 KVA and larger single phase, 3 KVA and larger three phase can be reverse connected without any adverse effects or loss in KVA capacity. The reason for this limitation in KVA size is, the turns ratio is the same as the voltage ratio. Example: A transformer with a 480 volt input, 240 volt output— can have the output connected to a 240 volt source and thereby become the primary or input to the transformer, then the original 480 volt primary winding will become the output or 480 volt secondary. On transformers rated below 1 KVA single phase, there is a turns ratio compensation on the low voltage winding. This means the low voltage winding has a greater voltage than the nameplate voltage indicates at no load. For example, a small single phase transformer having a nameplate voltage of 480 volts primary and 240 volts secondary, would actually have a no load voltage of approximately 250 volts, and a full load voltage of 240 volts. If the 240 volt winding were connected to a 240 volt source, then the output voltage would consequently be approximately 460 volts at no load and approximately 442 volts at full load. As the KVA becomes smaller, the compensation is greater— resulting in lower output voltages. When one attempts to use these transformers in reverse, the transformer will not be harmed; however, the output voltage will be lower than is indicated by the nameplate.

### 8. Can a Single Phase Transformer be used on a Three Phase source?

**Yes.** Any single phase transformer can be used on a three phase source by connecting the primary leads to any two wires of a three phase system, regardless of whether the source is three phase 3-wire or three phase 4-wire. The transformer output will be single phase.

### 9. Can Transformers develop Three Phase power from a Single Phase source?

**No.** Phase converters or phase shifting devices such as reactors and capacitors are required to convert single phase power to three phase.

### 10. How do you select transformers?

- (1) Determine primary voltage and frequency.
- (2) Determine secondary voltage required.
- (3) Determine the capacity required in volt-amperes.

This is done by multiplying the load current (amperes) by the load voltage (volts) for single phase. For example: if the load is 40 amperes, such as a motor, and the secondary voltage is 240 volts, then 240 x 40 equals 9600 VA. A 10 KVA (10,000

volt-amperes) transformer is required. ALWAYS SELECT THE TRANSFORMER LARGER THAN THE ACTUAL LOAD. This is done for safety purposes and allows for expansion, in case more load is added at a later date. For 3 phase KVA, multiply rated volts x load amps x 1.73 (square root of 3) then divide by 1000.

- (4) Determine whether taps are required. Taps are usually specified on larger transformers.
- (5) Use the selection charts in Section I.

**11. What terminations are provided?** Primary and Secondary Terminations are provided on ACME Dry-Type Transformers as follows:

- No lugs—lead type connection on
  - 0-25 KVA single phase
  - 0-15 KVA three phase
- Bus-bar terminations  
(drilled to NEMA standards)
- 37.5 -250 KVA single phase
- 25-500 KVA three phase

**12. Can 60 Hz transformers be used at higher frequencies?** ACME transformers can be used at frequencies above 60 Hz up through 400 Hz with no limitations provided nameplate voltages are not exceeded. However, 60 Hz transformers will have less voltage regulation at 400 Hz than 60 Hz.

**13. What is meant by regulation in a transformer?** Voltage regulation in transformers is the difference between the no load voltage and the full load voltage. This is usually expressed in terms of percentage. For example: A transformer delivers 100 volts at no load and the voltage drops to 95 volts at full load, the regulation would be 5%. ACME dry-type distribution transformers generally have regulation from 2% to 4%, depending on the size and the application for which they are used.

**14. What is temperature rise in a transformer?** Temperature rise in a transformer is the temperature of the windings and insulation above the existing ambient or surrounding temperature.

**15. What is "Class" in insulation?** Insulation class was the original method used to distinguish insulating materials operating at different temperature levels. Letters were used for different designations. Letter classifications have been replaced by insulation system temperatures in degrees Celsius. The system temperature is the maximum temperature at the hottest spot in the winding (coil). Graphical representations of six insulation systems recognized by Underwriters' Laboratories, Inc. are shown in Figure A. These systems are used by Acme for a large part of the product line.

**16. Is one insulation system better than another?** Not necessarily. It depends on the application and the cost benefit to be realized. Higher temperature class insulation systems cost more and larger transformers are more expensive to build. Therefore, the more expensive insulation systems are more likely to be found in the larger KVA units.

Referring to Figure A, small fractional KVA transformers use insulation class 130°C. Compound filled transformers use insulation class 180°C. Larger ventilated transformers are designed to use 220°C insulation.

All of these insulation systems will normally have the same number of years operating life. A well designed transformer, observing these temperature limits, will have a life expectancy of 20-25 years.

**17. Why should Dry-Type Transformers never be over-loaded?** Overloading of a transformer results in excessive temperature. This excessive temperature causes overheating which will result in rapid deterioration of the insulation and cause complete failure of the transformer coils.

**18. Are temperature rise and actual surface temperature related?** No. This can be compared with an ordinary light bulb. The filament temperature of a light bulb can exceed 2000 degrees, yet the surface temperature of the bulb is low enough to permit touching with bare hands.

**19. What is meant by "impedance" in transformers?** Impedance is the current limiting characteristic of a transformer and is expressed in percentage.

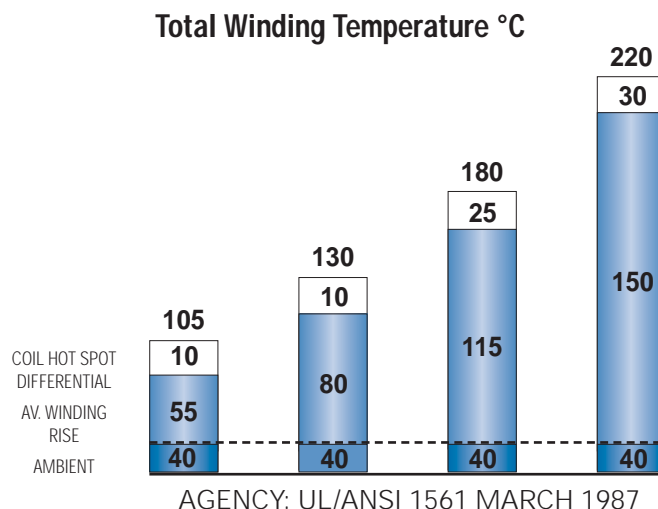

Figure A

**20. Why is impedance important?** It is used for determining the interrupting capacity of a circuit breaker or fuse employed to protect the primary of a transformer. **Example:** Determine a minimum circuit breaker trip rating and interrupting capacity for a 10 KVA single phase transformer with 4% impedance, to be operated from a 480 volt 60 Hz source.

Calculate as follows:

$$\text{Normal Full Load Current} = \frac{\text{Nameplate Volt Amps}}{\text{Line Volts}} = \frac{10,000 \text{ VA}}{480 \text{ V}} = 20.8 \text{ Amperes}$$

$$\text{Maximum Short Circuit Amps} = \frac{\text{Full Load Amps}}{4\%} = \frac{20.8 \text{ Amps}}{4\%} = 520 \text{ Amps}$$

The breaker or fuse would have a minimum interrupting rating of 520 amps at 480 volts.

**Example:** Determine the interrupting capacity, in amperes, of a circuit breaker or fuse required for a 75 KVA, three phase transformer, with a primary of 480 volts delta and secondary of 208Y/120 volts. The transformer impedance (Z) = 5%. If the secondary is short circuited (faulted), the following capacities are required:

$$\text{Normal Full Load Current} = \frac{\text{Volt Amps}}{\sqrt{3} \times \text{Line Volts}} = \frac{75,000 \text{ VA}}{\sqrt{3} \times 480 \text{ V}} = 90 \text{ Amps}$$

$$\text{Maximum Short Circuit Line Current} = \frac{\text{Full Load Amps}}{5\%} = \frac{90 \text{ Amps}}{5\%} = 1,800 \text{ Amps}$$

The breaker or fuse would have a minimum interrupting rating of 1,800 amps at 480 volts.

**NOTE:** The secondary voltage is not used in the calculation. The reason is the primary circuit of the transformer is the only winding being interrupted.

**21. Can Single Phase Transformers be used for Three Phase applications? Yes.** Three phase transformers are sometimes not readily available whereas single phase transformers can generally be found in stock. Three single phase transformers can be used in delta connected primary and wye or delta connected secondary. They should never be connected wye primary to wye secondary, since this will result in unstable secondary voltage. The equivalent three phase capacity when properly connected of three single phase transformers is three times the nameplate rating of each single phase transformer. For example: Three 10 KVA single phase transformers will accommodate a 30 KVA three phase load.

**22. Does ACME provide “Zig-Zag” Grounding Transformers? Yes.** Please refer to Page 31 for a special diagram which can be used to connect standard single phase off-the-shelf transformers in a three phase zig-zag manner. This system can be used for either grounding or developing a fourth wire from a three phase neutral. An example would be to change a 480 V — three phase — three wire system to a 480Y/277 V — three phase — four wire system.

**23. What color are ACME Dry-Type Transformers? ASA 61 (NEMA) light gray is used on all enclosed transformers from .050 to 500 KVA.**

**24. How do you select a transformer to operate in an ambient higher than 40° centigrade? When the ambient exceeds 40°C use the following chart for de-rating standard transformers.**

Maximum Ambient Temperature	Maximum Percentage of Loading
40°C (104°F)	100%
50°C (122°F)	92%
60°C (140°F)	84%

Instead of ordering custom built transformers to operate in ambients higher than 40°C, it is more economical to use a standard transformer of a larger KVA rating.

**25. Can transformers listed in this catalog be reconnected as autotransformers to increase their KVA rating? Several standard single phase transformers listed in this catalog can be connected as autotransformers. The KVA capacity will be greatly increased when used as an autotransformer, in comparison to the nameplate KVA as an insulating transformer. Examples of autotransformer applications are changing 600 volts to 480 volts in either single phase or three phase; changing 480 volts to 240 volts single or three phase or vice versa; or the developing of a fourth wire (neutral) from a 480 volt three phase three wire system for obtaining 277 volts single phase. This voltage is normally used for operating fluorescent lamps or similar devices requiring 277 volts. For further details showing KVA and voltage combinations for various autotransformer connections refer to Page 30 and 31 in this catalog.**

**26. Are ACME Transformers shown in this catalog U.L. Listed? All of the transformers, with few exceptions, are listed by Underwriters’ Laboratories and have met their rigorous requirements. We are also prepared to have transformers, which are not presently listed, submitted for listing to Underwriters’ upon the customer’s request. Please contact the factory for details.**

**27. Is CSA certification available for transformers shown in this catalog? Most ACME transformers shown in this catalog are certified by Canadian Standards Association. They have been designed and tested in accordance with the latest specifications. Please contact the factory if further details are required.**

**28. What is BIL and how does it apply to transformers listed in this catalog? BIL is an abbreviation for Basic Impulse Level. Impulse tests are dielectric tests that consist of the application of a high frequency steep wave front voltage between windings, and between windings and ground. The Basic Impulse Level of a transformer is a method of expressing the voltage surge (lightning, switching surges, etc.) that a transformer will tolerate without breakdown. All transformers manufactured in this catalog, 600 volts and below, will withstand the NEMA standard BIL rating, which is 10 KV. This assures the user that he will not experience breakdowns when his system is properly protected with lightning arrestors or similar surge protection devices.**

**29. What is polarity, when associated with a transformer? Polarity is the instantaneous voltage obtained from the primary winding in relation to the secondary winding. Transformers 600 volts and below are normally connected in additive polarity — that is, when tested the terminals of the high voltage and low voltage windings on the left hand side are connected together, refer to diagram below. This leaves one**

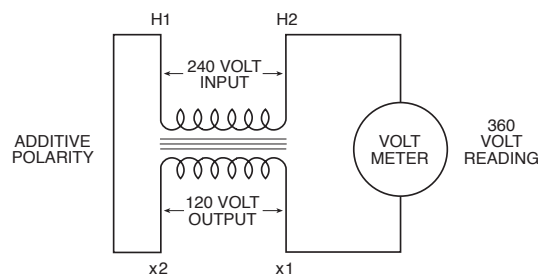



high voltage and one low voltage terminal unconnected. When the transformer is excited, the resultant voltage appearing across a voltmeter will be the sum of the high and low voltage windings. This is useful when connecting single phase transformers in parallel for three phase operations. Polarity is a term used only with single phase transformers.

**30. What is exciting current?** Exciting current, when used in connection with transformers, is the current or amperes required for excitation. The exciting current on most lighting and power transformers varies from approximately 10% on small sizes of about 1 KVA and smaller to approximately .5% to 4% on larger sizes of 750 KVA. The exciting current is made up of two components, one of which is a real component and is in the form of losses or referred to as no load watts; the other is in the form of reactive power and is referred to as KVAR.

**31. Will a transformer change Three Phase to Single Phase?** A transformer will not act as a phase changing device when attempting to change three phase to single phase. There is no way that a transformer will take three phase in and deliver single phase out while at the same time presenting a balanced load to the three phase supply system. There are, however, circuits available to change three phase to two phase or vice versa using standard dual wound transformers. Please contact the factory for two phase applications.

**32. Can air cooled transformers be applied to motor loads?** This is an excellent application for air cooled transformers. Even though the inrush or starting current is five to seven times normal running current, the resultant lower voltage caused by this momentary overloading is actually beneficial in that a cushioning effect on motor starting is the result. The tables on Pages 11 and 12 illustrate some typical transformer requirements for use with motor applications.

**33. How is an Acme Drive Isolation Transformer (DIT) different than a General Purpose Transformer?** DITs, as the name implies, are designed to be used with motor drives (AC and DC) and to provide isolation from the service line. They are specifically designed to withstand the "short circuit like" duty imposed by the firing of the thyristors. Harmonics generated by drives create added loads on the transformer. Therefore, it is important that a transformer of equal or greater KVA to that recommended by the drive manufacturer be installed for a particular motor application.

**34. How are transformers sized to operate Three Phase induction type squirrel cage motors?** The minimum transformer KVA rating required to operate a motor is calculated as follows:

$$\text{Minimum Transformer KVA} = \frac{\text{Running Load Amperes} \times 1.73 \times \text{Motor Operating Voltage}}{1000}$$

**NOTE:** If motor is to be started more than once per hour add 20% additional KVA.

Care should be exercised in sizing a transformer for an induction type squirrel cage motor as when it is started, the lock rotor amperage is approximately 5 to 7 times the running load amperage. This severe starting overload will result in a drop of the transformer output voltage. When the voltage is low the

torque and the horsepower of the motor will drop proportionately to the square of the voltage. For example: If the voltage were to drop to 70% of nominal, then motor horsepower and torque would drop to 70% squared or 49% of the motor nameplate rating.

If the motor is used for starting a high torque load, the motor may stay at approximately 50% of normal running speed as illustrated by the graph below:

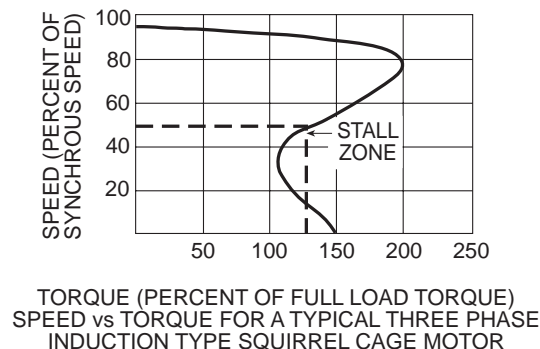

The underlying problem is low voltage at the motor terminals. If the ampere rating of the motor and transformer overcurrent device falls within the motor's 50% RPM draw requirements, a problem is likely to develop. The overcurrent device may not open under intermediate motor ampere loading conditions. Overheating of the motor and/or transformer would occur, possibly causing failure of either component.

This condition is more pronounced when one transformer is used to power one motor and the running amperes of the motor is in the vicinity of the full load ampere rating of the transformer. The following precautions should be followed:

- (1) When one transformer is used to operate one motor, the running amperes of the motor should not exceed 65% of the transformer's full load ampere rating.
- (2) If several motors are being operated from one transformer, avoid having all motors start at the same time. If this is impractical, then size the transformer so that the total running current does not exceed 65% of the transformer's full load ampere rating.

### 35. Why are Small Distribution Transformers not used for Industrial Control Applications?

Industrial control equipment demands a momentary overload capacity of three to eight times normal capacity. This is most prevalent in solenoid or magnetic contactor applications where inrush currents can be three to eight times as high as normal sealed or holding currents but still maintain normal voltage at this momentary overloaded condition. Distribution transformers are designed for good regulation up to 100 percent loading, but their output voltage will drop rapidly on momentary overloads of this type making them unsuitable for high inrush applications.

Industrial control transformers are designed especially for maintaining a high degree of regulation even at eight times normal load. This results in a larger and generally more expensive transformer. For a complete listing of ACME industrial control transformers, refer to Section V.

**36. Can 4-Winding Single Phase Transformer be auto-connected?** Yes. There are occasions where 480 volts single phase can be stepped down to 240 volts single phase by autoconnecting a standard 4-winding isolating transformer as shown in Figure 1. If connected in this manner, the nameplate KVA is doubled. For example: A 10 KVA load can be applied to a 5 KVA 4-winding transformer if connected per Figure 1.

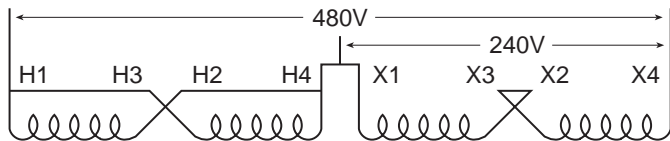

Figure 1

**37. What about balanced loading on Three Phases?** Each phase of a three phase transformer must be considered as a single phase transformer when determining loading. For example: A 45 KVA three phase transformer with a 208Y/120 volt secondary is to service 4 loads at 120 volts single phase each. These loads are 10 KVA, 5 KVA, 8 KVA, and 4 KVA.

**NOTE:** that maximum loading on any phase does not exceed 10 KVA. Each phase has a 15 KVA capacity.

$$\frac{45 \text{ KVA}}{3 \text{ phase}} = 15 \text{ KVA per phase}$$

If incorrect method is used, phase B will have an 18 KVA load which is 3 KVA above its normal capacity of 15 KVA and failure will result even though we only have a total load of 27 KVA on a 45 KVA transformer.

## Enclosure Definitions

**Type 1 Enclosures** — are intended for indoor use, primarily to provide a degree of protection against contact with the enclosed equipment.

**Type 2 Enclosures** — are intended for indoor use, primarily to provide a degree of protection against limited amounts of falling water and dirt.

**Type 3R Enclosures** — are intended for outdoor use, primarily to provide a degree of protection against falling rain, sleet and external ice formation.

### Definitions Pertaining to Enclosures

**Ventilated** — means constructed to provide for circulation of external air through the enclosure to remove excess heat, fumes or vapors.

**Non-Ventilated** — means constructed to provide no intentional circulation of external air through the enclosure.

**Indoor Locations** — are those areas protected from exposure to the weather.

**Outdoor Locations** — are those areas exposed to the weather.

**Hazardous (Classified) Locations** — are those areas, which may contain hazardous (classified) materials in sufficient quantity to create an explosion. See Article 500 of The National Electrical Code.

**38. What is meant by “Balanced Loading” on Single Phase Transformer applications?** Since most single phase transformers have a secondary voltage of 120/240, they will be operated as a three wire system. Care must be taken in properly distributing the load as the transformer secondary consists of 2 separate 120 volt windings. Each 120 volt winding is rated at one-half the nameplate KVA rating. For example: A 10 KVA transformer, 120/240 volt secondary is to service an 8 KVA load at 240 volts and two 1 KVA loads at 120 volts each.

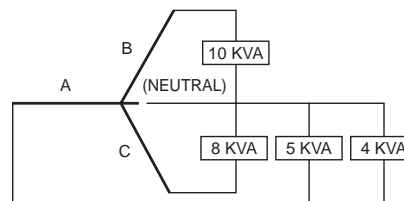

CORRECT WAY:

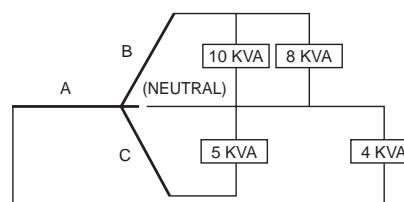

INCORRECT WAY:

If the incorrect method is used, winding A will be loaded at 6 KVA, and winding B will be loaded at 4 KVA. These do total 10 KVA but, since each winding is only rated at 5 KVA (1/2 of nameplate rating), we have an overloaded transformer and a certain failure.

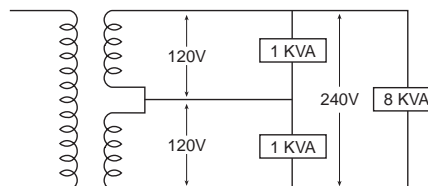

CORRECT WAY:

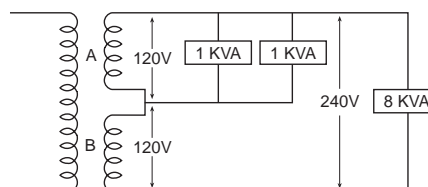

INCORRECT WAY:

**39. What are typical applications for transformers?** ACME transformers should be specified to:

- (1) Distribute power at high voltage.
- (2) Eliminate double wiring.
- (3) Operate 120 volt equipment from power circuits.
- (4) Insulate circuits/establish separately derived circuits.
- (5) Provide 3-wire secondary circuits.
- (6) Buck and Boost (See Section VII).
- (7) Provide electrostatic shielding for transient noise protection.

# Steps for Selecting the Proper Transformer

## SINGLE PHASE LOADS

### 1. Determine electrical load

- Voltage required by load.
- Amperes or KVA capacity required by load.
- Frequency in Hz (cycles per second).
- Verify load is designed to operate on a single phase supply.

All of the above information is standard data normally obtained from equipment nameplates or instruction manuals.

### 2. Determine supply voltage

- Voltage of supply (source).
- Frequency in Hz (cycles per second).

The frequency of the line supply and electrical load must be the same. Select single phase transformer designed to operate at this frequency, having a primary (input) equal to the supply voltage and a secondary (output) equal to the voltage required by the load.

### 3. If the load nameplate expresses a rating in KVA, a transformer can be directly selected from the charts. Choose from a group of transformers with primary and secondary voltages matching those you have just determined.

- Select a transformer with a standard KVA capacity **equal to or greater than** that needed to operate the load.
- Primary taps are available on most models to compensate for line voltage variations. (Refer to question #2 in the Transformer Questions and Answers Section on page 6.)
- When load ratings are given only in amperes, tables 1 and 2 or the following formulas may be used to determine proper KVA size for the required transformer.

(1) To determine **KVA** when volts and amperes are known:

$$\text{KVA} = \frac{\text{Volts} \times \text{Amps}}{1000}$$

(2) To determine **Amperes** when KVA and volts are known:

$$\text{Amps} = \frac{\text{KVA} \times 1000}{\text{Volts}}$$

## Single Phase Example

**Question:** Select a transformer to meet the following conditions. Load is single phase lighting using incandescent lamps. Each fixture requires 1.3 amps @ 120 volts, 1 phase, 60 Hz, power factor of unity. The installation requires 52-100 watt fixtures. The desired circuit distributing power to the light fixtures is 120/240 volt, three wire, single phase. The supply voltage is 460 volt, 3 phase.

**Answer:** Compute the KVA required.

$$\frac{1.3 \text{ amps} \times 120 \text{ volts}}{1000} = .156 \text{ KVA}$$

For each lighting fixture

Always use amps x volts to compute VA, never use lamp wattage.  $.156 \text{ KVA} / \text{Fixture} \times 52 \text{ Fixture} = 8.11 \text{ KVA}$ . The two sizes (KVA) nearest 8.11 KVA are 7.5 KVA and 10 KVA. Use the 10 KVA. This will not overload the transformer and allows some capacity, 1.89 KVA, for future loads. Since the supply is 460 V (not 480 V) use the 456 V tap. This will produce approximately 120 volts on output. If the tap is not used, the output will be 115 V compared to the desired 120 V. Note the transformer selected is single phase but the supply is 480 V, 3 phase. Single phase is obtained by using any 2 wires of the 3 phase supply.

TABLE 1

Full Load Current in Amperes—  
Single Phase Circuits

KVA	120V	208V	240V	277V	380V	440V	480V	600V
.050	0.4	0.2	0.2	0.2	0.1	0.1	0.1	0.1
.100	0.8	0.5	0.4	0.3	0.2	0.2	0.2	0.2
.150	1.2	0.7	0.6	0.5	0.4	0.3	0.3	0.3
.250	2.0	1.2	1.0	0.9	0.6	0.5	0.5	0.4
.500	4.2	2.4	2.1	1.8	1.3	1.1	1.0	0.8
.750	6.3	3.6	3.1	2.7	2.0	1.7	1.6	1.3
1	8.3	4.8	4.2	3.6	2.6	2.3	2.1	1.7
1.5	12.5	7.2	6.2	5.4	3.9	3.4	3.1	2.5
2	16.7	9.6	8.3	7.2	5.2	4.5	4.2	3.3
3	25	14.4	12.5	10.8	7.9	6.8	6.2	5.0
5	41	24.0	20.8	18.0	13.1	11.3	10.4	8.3
7.5	62	36	31	27	19.7	17	15.6	12.5
10	83	48	41	36	26	22.7	20.8	16.7
15	125	72	62	54	39	34	31	25
25	208	120	104	90	65	57	52	41
37.5	312	180	156	135	98	85	78	62
50	416	240	208	180	131	114	104	83
75	625	360	312	270	197	170	156	125
100	833	480	416	361	263	227	208	166
167	1391	802	695	602	439	379	347	278
250	2083	1201	1041	902	657	568	520	416

TABLE 2

Full Load Amperes  
Single Phase A.C. Motors ①

HORSE-POWER	115 V	208 V	230 V	MIN. TRANSFORMER KVA
1/6	4.4	2.4	2.2	.53
1/4	5.8	3.2	2.9	.70
1/3	7.2	4.0	3.6	.87
1/2	9.8	5.4	4.9	1.18
3/4	13.8	7.6	6.9	1.66
1	16	8.8	8	1.92
1.5	20	11.0	10	2.40
2	24	13.2	12	2.88
3	34	18.7	17	4.10
5	56	30.8	28	6.72
7.5	80	44	40	9.6
10	100	55	50	12.0

① When motor service factor is greater than 1, increase full load amps proportionally.

**Example:** If service factor is 1.15, increase above amp values by 15%.

$$\text{1 Phase KVA} = \frac{\text{Volts} \times \text{Amps}}{1000}$$

**NOTE:** If motors are started more than once per hour, increase minimum transformer KVA by 20%.

## THREE PHASE LOADS

## 1. Determine electrical load

- Voltage required by load.
- Amperes or KVA required by load.
- Frequency in Hz (cycles per second).
- Verify load is designed to operate on three phase.

All the above information is standard data normally obtained from equipment nameplates or instruction manuals.

## 2. Determine supply voltage

- Voltage of supply (source).
- Frequency in Hz (cycles per second).

The frequency of the line supply and electrical load must be the same. A three phase transformer is selected which is designed to operate at this frequency having a primary (input) equal to the supply voltage and a secondary (output) equal to the voltage required by the load.

## 3. If the load nameplate expresses a rating in KVA, a transformer can be directly selected from the charts. Choose from the group of transformers with primary and secondary voltages matching that which you have just determined.

- Select a transformer with a standard KVA capacity **equal to or greater than** that needed to operate the load.
- Primary taps are available on most models to compensate for line voltage variations. (Refer to question #2 in the Transformer Questions and Answers Section on page 6.)
- When load ratings are given only in amperes, tables 3 and 4 or the following formulas may be used to determine proper KVA size for the required transformer.

(1) To determine three phase **KVA** when volts and amperes are known:

$$\text{Three Phase KVA} = \frac{\text{Volts} \times \text{Amps} \times 1.73}{1000}$$

(2) To determine **Amperes** when KVA and volts are known:

$$\text{Amps} = \frac{3 \text{ Phase KVA} \times 1000}{\text{Volts} \times 1.73}$$

## Three Phase Example

**Question:** Select a transformer to fulfill the following conditions. Load is a three phase induction motor, 25 horsepower @ 240 volts, 60 Hz and a heater load of 4 kilowatts @ 240 volts single phase. The supply voltage is 480Y/277, three phase, 4 wire.

**Answer:** Compute the KVA required. **Motor** — From table 4 the current is 68 amps.

$$\frac{240 \text{ volts} \times 68 \text{ amps} \times 1.73}{1000} = 28.2 \text{ KVA}$$

(The KVA can also be obtained from table 4).

**Heater** — 4 KVA

A three phase transformer must be selected so that any one phase is not overloaded. Each phase should have the additional 4 KVA rating required by the heater even though the heater will operate on one phase only. So, the transformer should have a minimum KVA rating of 28.2 + 4 + 4 + 4 or 40.2 KVA. Refer to the appropriate selection chart. A 480 delta primary — 240 delta secondary transformer may be used on a 4 wire, 480Y/277 volt supply. The fourth wire (neutral) is not connected to the transformer. To not overload the transformer, a 45 KVA transformer should be selected.

**NOTE:** Any two wires of the 240 volts, 3 phase developed by the secondary of the transformer may be used to supply the heater. Any 2 wires of a 3 phase system is single phase.

TABLE 3

Full Load Current in Amperes—  
Three Phase Circuits

KVA	208 V	240 V	380 V	440 V	480 V	600 V
3	8.3	7.2	4.6	3.9	3.6	2.9
4.5	12.5	10.8	6.8	5.9	5.4	4.3
6	16.6	14.4	9.1	7.8	7.2	5.8
9	25	21.6	13.7	11.8	10.8	8.6
15	41	36	22.8	19.6	18.0	14.4
22.5	62	54	34.2	29	27	21.6
30	83	72	45.6	39	36	28
45	124	108	68.4	59	54	43
75	208	180	114	98	90	72
112.5	312	270	171	147	135	108
150	416	360	228	196	180	144
225	624	541	342	294	270	216
300	832	721	456	392	360	288
500	1387	1202	760	655	601	481
750	2081	1804	1139	984	902	721
1000	2775	2405	1519	1312	1202	962

TABLE 4

Full Load Amperes  
Three Phase A.C. Motors ①

HORSE-POWER	208 V	230 V	460 V	575 V	MIN. TRANSFORMER KVA
1/2	2.2	2.0	1.0	0.8	0.9
3/4	3.1	2.8	1.4	1.1	1.2
1	4.0	3.6	1.8	1.4	1.5
2	7.5	6.8	3.4	2.7	2.7
3	10.7	9.6	4.8	3.9	3.8
5	16.7	15.2	7.6	6.1	6.3
10	31	28	14	11	11.2
15	46	42	21	17	16.6
20	59	54	27	22	21.6
25	75	68	34	27	26.6
30	88	80	40	32	32.4
40	114	104	52	41	43.2
50	143	130	65	52	52
60	170	154	77	62	64
75	211	192	96	77	80
100	273	248	124	99	103
125	342	312	156	125	130
150	396	360	180	144	150
200	528	480	240	192	200

① When motor service factor is greater than 1, increase full load amps proportionally.

**Example:** If service factor is 1.15, increase above amp values by 15%.

$$\text{3 Phase KVA} = \frac{\text{Volts} \times \text{Amps} \times 1.73}{1000}$$

**NOTE:** If motors are started more than once per hour, increase minimum transformer KVA by 20%.

## Where Are Buck-Boost Transformers Used?

A typical buck-boost application is 120 volts in, 12 volts out for low voltage lighting or control circuitry. In most applications, this low voltage transformer is field connected as an autotransformer. (See question 2 for the definition of an autotransformer). Buck-boost transformers provide tremendous capabilities and flexibility in KVA sizes and input/output voltage combinations. **Basically you get 75 different transformers... all in one convenient package.**

Other buck-boost applications are, where (A) low supply voltage exists because equipment is installed at the end of a bus system; (B) the supply system is operating at or over its design capacity; and (C) where overall consumer demands may be so high the utility cuts back the supply voltage to the consumer causing a "brownout."

## Why Use Buck-Boost Instead of Another Type Transformer?

Take a look at the advantages and disadvantages of using a buck-boost transformer (autotransformer) compared to a standard isolation transformer of the proper size and voltage combination.

As you can see, the advantages are many, the economies great. Buck-boost transformers are readily available from the stock of your nearest Power Distribution Products Distributor.

ADVANTAGES	DISADVANTAGES
More efficient	No circuit isolation
Smaller & lighter	Cannot create a neutral
5-10 times increase in KVA	Application voltages and KVA don't match the nameplate voltages and KVA
Versatile, many applications	
Lower cost	



## Proper Voltage Is Critical

With nearly two-thirds of all electrical loads being A.C. motor loads, maintenance of the proper voltage to that motor is very important. If the supply line voltage is not maintained, motor winding current is increased causing reduced motor torque and escalating motor temperature, all of which results in the rapid loss of insulation life expectancy.

In addition to motor loads, the detrimental effects of low voltage on both resistive heating loads and incandescent lighting output is illustrated in the chart.

**Anytime you have a lower than standard voltage, equipment damage and failure can result.**

Buck-boost transformers are an economical way to correct this potentially very serious problem. **Anytime** a line voltage change in the 5-20% range is required, a buck-boost transformer should be considered as your first line of defense.



## How Low Voltage Affects Various Equipment Operations and Functions

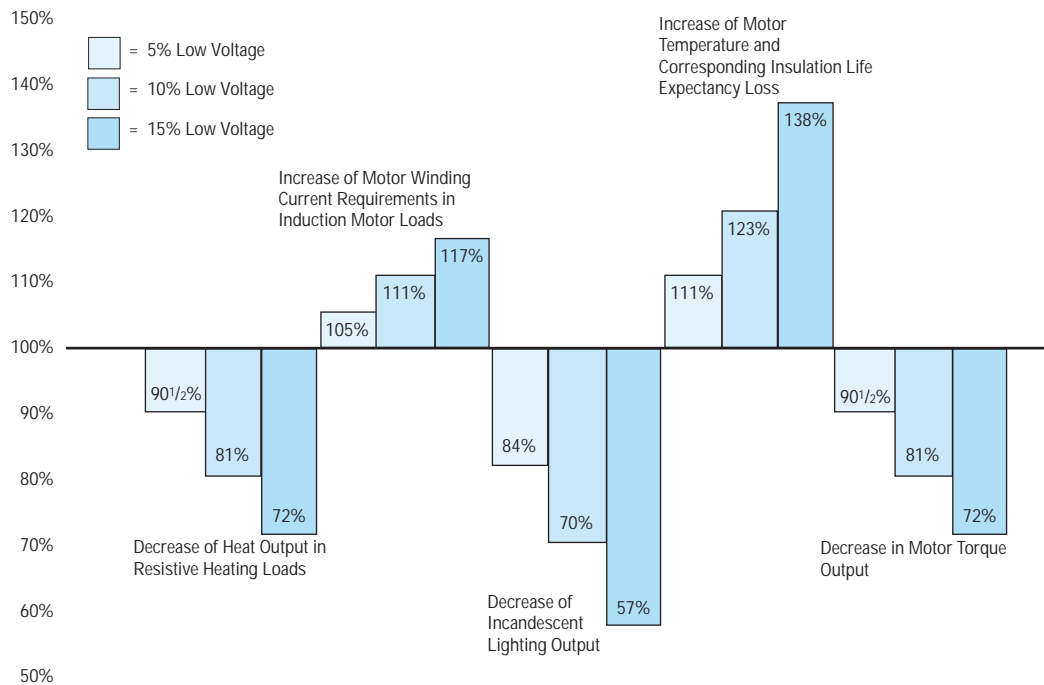

## Questions & Answers About Buck-Boost Transformers

### 1. What is a buck-boost transformer?

Buck-boost transformers are small single phase transformers designed to reduce (buck) or raise (boost) line voltage from 5 - 20%. The most common example is boosting 208 volts to 230 volts, usually to operate a 230 volt motor such as an air-conditioner compressor, from a 208 volt supply line.

Buck-boosts are a standard type of single phase distribution transformers, with primary voltages of 120, 240 or 480 volts and secondaries typically of 12, 16, 24, 32 or 48 volts. They are available in sizes ranging from 50 volt amperes to 10 kilo-volt amperes.

Buck-boost transformers are shipped ready to be connected for a number of possible voltage combinations.

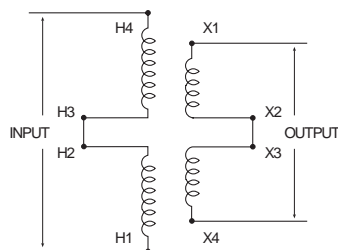

Figure 1. Buck-boost transformer connected as a low voltage insulating transformer (primary and secondary windings shown series connected).

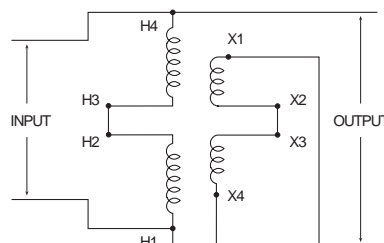

Figure 2. Same buck-boost transformer connected as a boosting autotransformer. The connection from H1 to X4 "converted" the unit to an autotransformer.

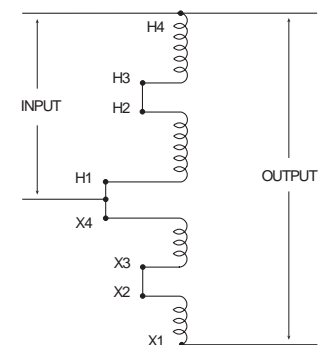

Figure 3. Illustration No. 2 shown with the primary and secondary windings "straightened".

### 3. What is the difference between a buck-boost transformer and an autotransformer?

When a primary lead wire and secondary lead wire of a buck-boost transformer are connected together electrically, in a recommended voltage bucking or boosting connection, the transformer is in all respects, an autotransformer. However, if the interconnection between the primary and secondary winding is not made, then the unit is an insulating type transformer.

## Applications

### 4. Why are they used?

Electrical and electronic equipment is designed to operate on standard supply voltage. When the supply voltage is constantly too high or too low, (usually more than 55%), the equipment fails to operate at maximum efficiency. A buck and boost transformer is a simple and ECONOMICAL means of correcting this off-standard voltage.

### 5. What are the most common applications for buck-boost transformers?

Boosting 208V to 230V or 240V and vice versa for commercial and industrial air conditioning systems; boosting 110V to 120V and 240V to 277V for lighting systems; voltage correction for heating systems and induction motors of all types. Many applications exist where supply voltages are constantly above or below normal.

### 6. Can buck-boost transformers be used to power low voltage circuits?

**Yes**, low voltage control, lighting circuits, or other low voltage applications requiring either 12V, 16V, 24V, 32V or 48V. The unit is connected as an insulating transformer and the nameplate KVA rating is the transformer's capacity.

## Operation and Construction

### 7. Why do buck-boost transformers have 4 windings?

**To make them versatile!** A four winding buck-boost transformer (2 primary and 2 secondary windings) can be connected eight different ways to provide a multitude of voltage and KVA outputs. A two winding (1 primary & 1 secondary) buck-boost transformer can be connected only one way.

### 8. Will a buck-boost transformer stabilize voltage?

**No**. The output voltage is a function of the input voltage. If the input voltage varies, then the output voltage will also vary by the same percentage.

## Load Data

### 9. Are there any restrictions on the type of load that can be operated from a buck-boost transformer?

**No**, there are no restrictions.

### 10. Why can a buck-boost transformer operate a KVA load many times larger than the KVA rating on its nameplate?

Since the transformer has been auto-connected in such a fashion that the 22V secondary voltage is added to the 208V primary voltage, it produces 230V output.

The autotransformer KVA is calculated:

$$\text{KVA} = \frac{\text{Output Volts} \times \text{Secondary Amps}}{1000}$$

$$\text{KVA} = \frac{230 \text{ V} \times 41.67 \text{ Amps}}{1000} = 9.58 \text{ KVA}$$

The picture to the left illustrates the difference in physical size between the autotransformer of 1 KVA, capable of handling a 9.58 KVA load, and an isolation transformer capable of handling a 7.5 KVA load.

To cite an example . . . a model T-1-11683 buck-boost transformer has a nameplate KVA rating of 1 KVA, but when it's connected as an autotransformer boosting 208V to 230V, its KVA capacity increases to 9.58 KVA. The key to understanding the operation of buck-boost transformers lies in the fact that the secondary windings are the only parts of the transformer that do the work of transforming voltage and current. In the example above, only 22 volts are being transformed (boosted) — i.e. 208V + 22V = 230V. This 22V transformation is carried out by the secondary windings which are designed to operate at a maximum current of 41.67 amps (determined by wire size of windings).



(1 KVA) T-1-11683

(7.5 KVA) T-2-53515-3S

$$\text{Maximum Secondary Amps} = \frac{\text{nameplate KVA} \times 1000}{\text{secondary volts}}$$

$$\text{Maximum Secondary Amps} = \frac{1.0 \text{ KVA} \times 1000}{24 \text{ V}} = \frac{1000 \text{ VA}}{24 \text{ V}} = 41.67 \text{ amps}$$

### 11. Can buck-boost transformers be used on motor loads?

**Yes**, either single or three phase. Refer to the motor data charts in Section I for determining KVA and Amps required by NEMA standard motors.

### 12. How are single phase and three phase load Amps and load KVA calculated?

$$\text{Single phase Amps} = \frac{\text{KVA} \times 1000}{\text{Volts}}$$

$$\text{Three phase Amps} = \frac{\text{KVA} \times 1000}{\text{Volts} \times 1.73}$$

$$\text{Single phase KVA} = \frac{\text{Volts} \times \text{Amps}}{1000}$$

$$\text{Three phase KVA} = \frac{\text{Volts} \times \text{Amps} \times 1.73}{1000}$$

## Three-Phase

### 13. Can buck-boost transformers be used on three-phase systems as well as single phase systems?

**Yes**. A single unit is used to buck or boost single phase voltage — two or three units are used to buck or boost three phase voltage. The number of units to be used in a three-phase installation depends on the number of wires in the supply line. If the three-phase supply is 4 wire Y, use three buck-boost transformers. If the 3-phase supply is 3 wire Y (neutral not available), use two buck-boost transformers. Refer to three-phase selection charts.

### 14. Should buck-boost transformers be used to develop a three-phase 4 wire Y circuit from a three-phase 3 wire delta circuit?

**No**. A three phase “wye” buck-boost transformer connection should be used only on a 4 wire source of supply. A delta to wye connection does not provide adequate current capacity to accommodate unbalanced currents flowing in the neutral wire of the 4 wire circuit.

3 PHASE CONNECTIONS

INPUT (SUPPLY SYSTEM)	DESIRED OUTPUT CONNECTION	
DELTA 3 wire	WYE 3 or 4 wire	DO NOT USE
OPEN DELTA 3 wire	WYE 3 or 4 wire	DO NOT USE
WYE 3 or 4 wire	CLOSED DELTA 3 wire	DO NOT USE
WYE 4 wire	WYE 3 or 4 wire	OK
WYE 3 or 4 wire	OPEN DELTA 3 wire	OK
CLOSED DELTA 3 wire	OPEN DELTA 3 wire	OK

### 15. Why isn't a closed delta buck-boost connection recommended?

A closed delta buck-boost auto transformer connection requires more transformer KVA than a “wye” or open delta connection and phase shifting occurs on the output. Consequently the closed delta connection is more expensive and electrically inferior to other three-phase connections.

## Connection and Frequency

### 16. How does the installer or user know how to connect a buck-boost transformer?

The connection chart packed with each unit shows how to make the appropriate connections. These same connection charts are also shown in this section (page 118).

### 17. Can 60 Hertz buck-boost transformers be used on a 50 Hertz service?

**No**. Acme buck-boost transformers should be operated only at the frequencies recommended. However, units recommended for 50 cycle operation are suitable for 60 cycle operation but not vice versa.

## Selection

### 18. How do you select a buck-boost transformer?

Refer to the selection steps on page 109 for easy 4-step selection, then go to the charts. Also, pages 12 and 13 are helpful for determining buck-boost KVA when only the H.P. rating of a motor is available.

## Nameplate Data

### 19. Why are buck-boost transformers shipped from the factory as insulating transformers and not preconnected at the factory as autotransformers?

A four winding buck-boost transformer can be auto connected eight different ways to provide a multitude of voltage and KVA output combinations. The proper transformer connection depends on the user's supply voltage, load voltage and load KVA. Consequently, it is more feasible for the manufacturer to ship the unit as an insulating transformer and allow the user to connect it on the job site in accordance with the available supply voltage and requirements of his load.

### 20. Why is the isolation transformer KVA rating shown on the nameplate instead of the autotransformer KVA rating?

The KVA rating of a buck-boost transformer when auto connected depends on the amount of voltage buck or boost. Since the amount of voltage buck or boost is different for each connection, it is physically impossible to show all of the various voltage combinations and attainable KVA ratings on the nameplate. A connection chart showing the various attainable single phase and three-phase connections is packed with each unit.

## Safety

### 21. Do buck-boost transformers present a safety hazard usually associated with autotransformers?

**No**. Most autotransformers, if they are not of the buck-boost variety, change voltage from one voltage class to another. (Example 480V to 240V) In a system where one line is grounded, the user thinks he has 240V; yet due to the primary and secondary being tied together, it is possible to have 480V to ground from the 240V output. A buck-boost transformer only changes the voltage a small amount, such as 208V to 240V. This small increase does not represent a safety hazard, as compared to a buck of 480V to 240V. Refer to Figure on the following page.



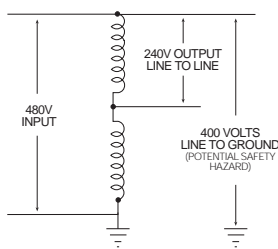

## Sound Levels

### 22. Are buck-boost transformers as quiet as standard isolation transformers?

**Yes.** However, an auto-connected buck-boost transformer will be quieter than an isolation transformer capable of handling the same load. The isolation transformer would have to be physically larger than the buck-boost transformer, and small transformers are quieter than larger ones. (Example) 1 KVA — 40 db; 75 KVA — 50 db. (db is a unit of sound measure).

## Cost and Life Expectancy

### 23. How does the cost of a buck-boost transformer compare to that of an insulating transformer — both capable of handling the same load?

For the most common buck-boost applications, the dollar savings are generally greater than 75% compared to the use of an insulating type distribution transformer for the same application.

### 24. What is the life expectancy of a buck boost transformer?

The life expectancy of a buck-boost transformer is the same as the life expectancy of other dry type transformers.

## National Electrical Code

### 25. Your catalog indicates that a buck-boost transformer is suitable for connecting as an AUTOTRANSFORMER. What is the definition of an autotransformer and how does it differ from an isolation transformer?

An autotransformer is a transformer in which the primary (input) and the secondary (output) are electrically connected to each other. An isolation transformer, also known as an insulating transformer, has complete electrical separation between the primary (input) and the secondary (output). This is illustrated in the drawing below

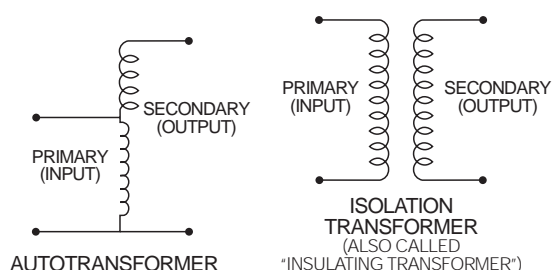

An autotransformer changes or transforms only a portion of the electrical energy it transmits. The rest of the electrical energy flows directly through the electrical connections between the primary and secondary. An isolation transformer (insulating transformer) changes or transforms all of the electrical energy it transmits.

Consequently, an autotransformer is smaller, lighter in weight, and less costly than a comparable KVA size insulating transformer.

Please refer to Question 27 for additional information on autotransformers.

Buck-boost transformers are frequently field-connected as autotransformers.

### 26. Buck-boost transformers are almost always installed as auto-transformers. Does the N.E.C. (National Electrical Code) permit the use of autotransformers?

**Yes.** Please refer to N.E.C. Article 450-4, "Autotransformers 600 Volts, Nominal, or Less." Item (a) explains how to over-current protect an autotransformer; item (b) explains that an insulating transformer such as a buck-boost transformer may be field connected as an autotransformer.

### 27. When a buck-boost transformer is connected as an autotransformer such as boosting 208V to 230V, the KVA is greatly increased. What is the procedure for determining the size (ampere rating) of the over-current protective device such as a fuse or circuit breaker?

The National Electrical Code Article 450-4 addresses over-current protection of autotransformers. A copy is reproduced below for easy reference.

#### 450-4. Autotransformers 600 Volts, Nominal, or Less.

**(a) Overcurrent Protection.** Each autotransformer 600 volts, nominal, or less shall be protected by an individual overcurrent device installed in series with each ungrounded input conductor. Such overcurrent device shall be rated or set at not more than 125 percent of the rated full-load input current of the autotransformer. An overcurrent device shall not be installed in series with the shunt winding (the winding common to both the input and the output circuits) of the autotransformer between Points A and B as shown in Diagram 450-4.

Diagram 450-4

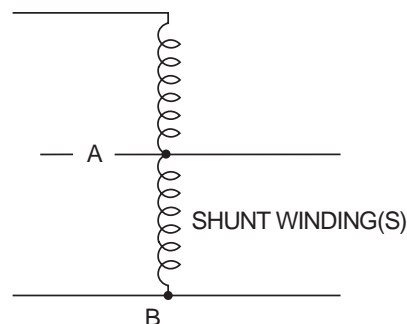

**Exception:** Where the rated input current of an autotransformer is 9 amperes or more and 125 percent of this current does not correspond to a standard rating of a fuse or non-adjustable circuit breaker, the next higher standard rating described in Section 240-6 shall be permitted. When the rated input current is less than 9 amperes, an overcurrent device rated or set at not more than 167 percent of the input current shall be permitted.

**(b) Transformer Field-Connected as an Autotransformer.**

A transformer field-connected as an autotransformer shall be identified for use at elevated voltage.

28. I have noted the reprint of the N.E.C. (National Electrical Code), Article 450-4 shown in the previous question covering autotransformer overcurrent protection. Could you explain this article in detail by citing an example?

An example of an everyday application is always a good way to explain the intent of the "Code." **Example:** A 1 KVA transformer Catalog No. T-1-11683 has a primary of 120 x 240V and a secondary of 12 x 24V. It is to be connected as an autotransformer at the time of installation to raise 208V to 230V single phase.

When this 1 KVA unit is connected as an autotransformer for this voltage combination, its KVA rating is increased to 9.58 KVA (may also be expressed as 9,580 VA). This is the rating to be used for determining the full load input amps and the sizing of the overcurrent protect device (fuse or breaker) on the input.

Full Load Input Amps =

$$\frac{9,580 \text{ Volt Amps}}{208 \text{ Volts}} = 46 \text{ Amps}$$

When the full load current is greater than 9 amps, the overcurrent protective device (usually a fuse or non-adjustable breaker) amp rating can be up to 125 percent of the full load rating of the autotransformer input amps.

Max. amp rating of the overcurrent device

$$= 46 \text{ amps} \times 125\% = 57.5 \text{ amps}$$

The National Electrical Code, Article 450-4 (a) Exception, permits the use of the next higher standard ampere rating of the overcurrent device. This is shown in Article 240-6 of the N.E.C.

Max. size of the fuse or circuit breaker  
= 60 amps

## Steps for Selecting the Proper Buck-Boost Transformer

**You should have the following information before selecting a buck-boost transformer.**

**Line Voltage** — The voltage that you want to buck (decrease) or boost (increase). This can be found by measuring the supply line voltage with a voltmeter.

**Load Voltage** — The voltage at which your equipment is designed to operate. This is listed on the nameplate of the load equipment.

**Load KVA or Load Amps** — You do not need to know both — one or the other is sufficient for selection purposes. This information usually can be found on the nameplate of the equipment that you want to operate.

**Frequency** — The supply line frequency must be the same as the frequency of the equipment to be operated — either 50 or 60 cycles.

**Phase** — The supply line should be the same as the equipment to be operated — either single or three phase.

### Four Step Selection

1. A series of LINE VOLTAGE and LOAD VOLTAGE combinations are listed across the top of each selection chart. Select a LINE VOLTAGE and LOAD VOLTAGE combination from ANY of the charts that comes closest to matching the LINE VOLTAGE and LOAD VOLTAGE of your application.
2. Read down the column you have selected until you reach either the LOAD KVA or LOAD AMPS of the equipment you want to operate. You probably will not find the exact value of LOAD KVA or LOAD AMPS so go to the next higher rating.
3. From this point, read across the column to the far left-hand side and you have found the catalog number of the exact buck-boost transformer you need. Refer to the catalog number listing on page 116 for dimensions.
4. CONNECT the transformer according to the connection diagram specified at the bottom of the column where you selected YOUR LINE VOLTAGE and LOAD VOLTAGE combination. Connection diagrams are found at the end of this section.

This same connection information is packed with each buck-boost transformer.